

SHARPE[®] VALVES

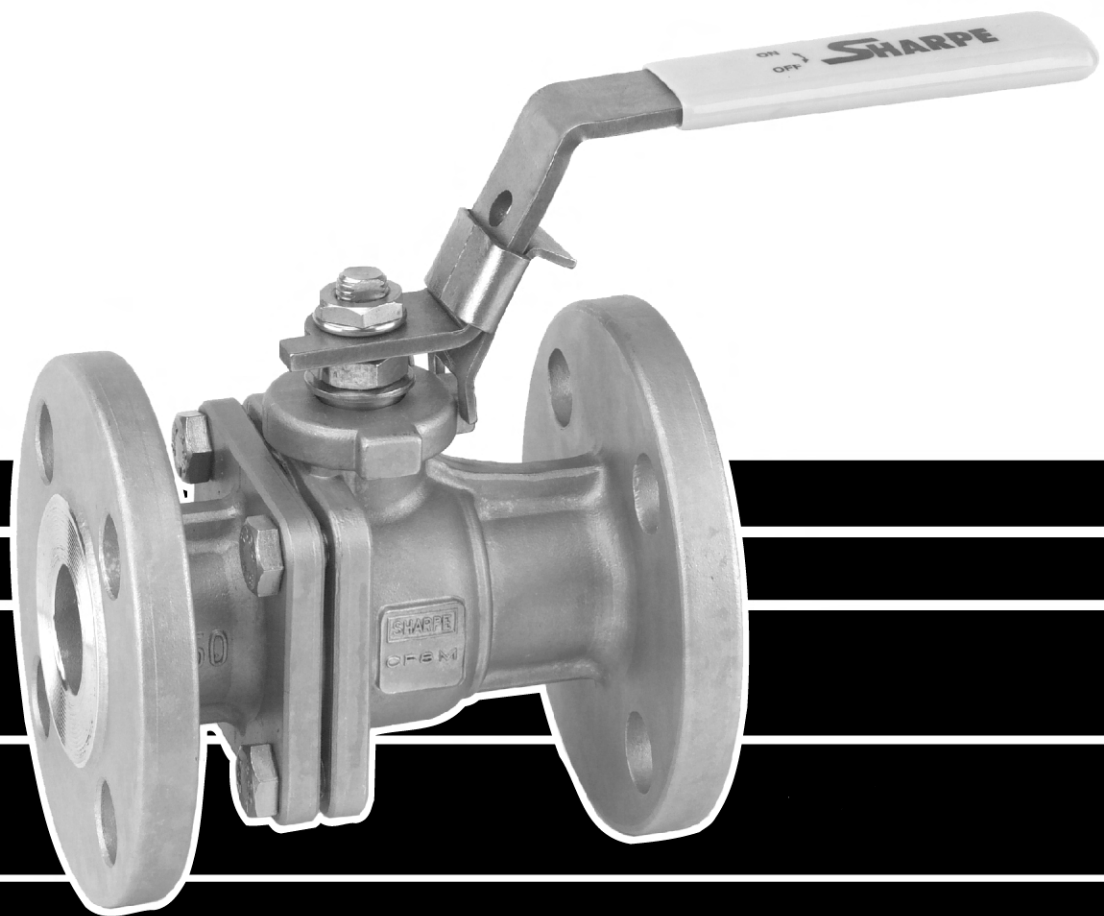

**SERIES 49
CLASS 150
FLANGED FULL PORT BALL VALVE**

SERIES 49 VALVE PARTS AND IDENTIFICATION

CLASS 150 BLOW OUT PROOF STEM LOCKING DEVICE

APPLICABLE STANDARDS	
Wall Thickness	ASME B16.34
Face to Face Dimensions	ASME B16.10
Flange Dimensions	ASME B16.5
Pressure Tests	ASME B16.34 API 598 (Optional)
Basic Design	ASME B16.34

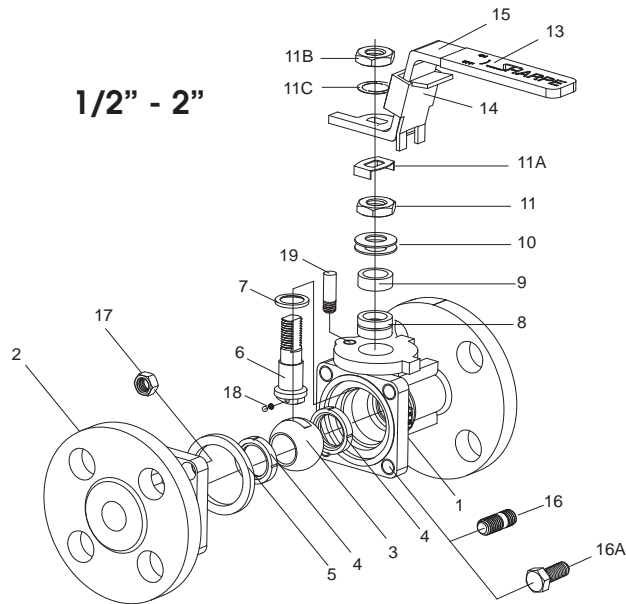

1/2" - 2"

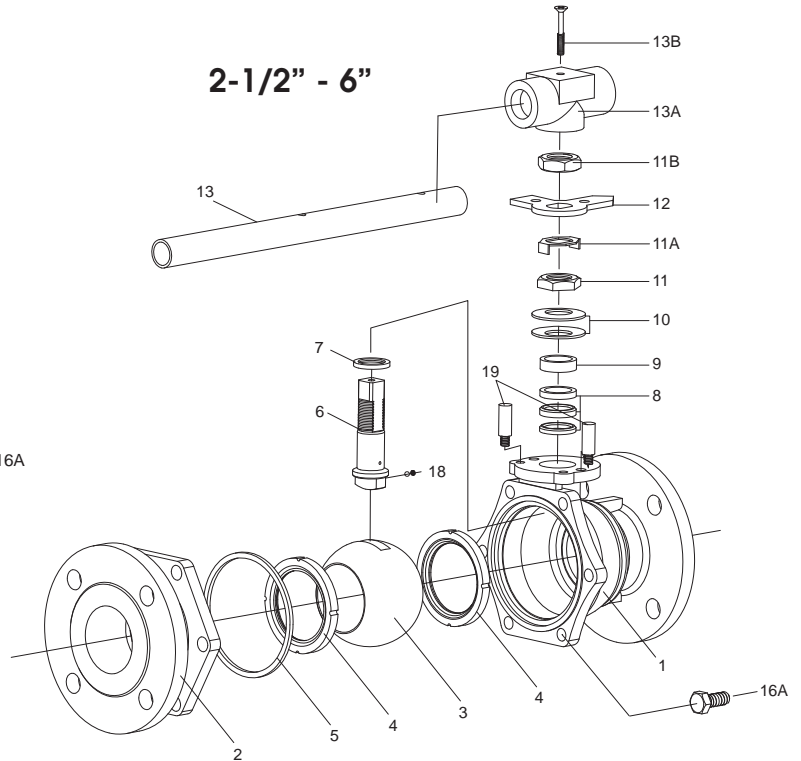

2-1/2" - 6"

PART NO.	PART	QTY.	MATERIAL
1	Body	1	Carbon Steel ASTM A216 WCB 316 Stainless Steel ASTM A351 CF8M
2	End Connector	4	Carbon Steel ASTM A216 WCB 316 Stainless Steel ASTM A351 CF8M
3	Ball	1	316 Stainless Steel
4	Seat	2	Reinforced PTFE
5	Body Seal	1	PTFE
6	Stem	1	316 Stainless Steel
7	Thrust Bearing	1	316 Stainless Steel
8	Stem Packing (1/2" - 2") (2-1/2" - 6")	2 3	PTFE PTFE
9	Gland Packing	1	304 Stainless Steel
10	Belleville Washer	2	304 Stainless Steel
11	Packing Nut	1	304 Stainless Steel
11A	Lock Tab	1	Stainless Steel
11B	Nut	1	304 Stainless Steel
11C	Nut Washer	1	304 Stainless Steel
12	Stopper	1	304 Stainless Steel

PART NO.	PART	QTY.	MATERIAL
13	Handle	1	304 Stainless Steel (1/2" - 2") Galvanized Steel (2-1/2" - 6")
13A	Wrench Block	1	304 Stainless Steel (2-1/2" - 6")
13B	Handle Bolt	1	304 Stainless Steel (2-1/2" - 6")
14	Locking Device (1/2" - 2")	1	304 Stainless Steel
15	Sleeve	1	PVC
16	Body Stud (1/2" - 1")	4	A193 ASTM A193, Gr. B8M (Stainless Steel) A193 ASTM A193, Gr. B7 (Carbon Steel)
16A	Body Bolt (1-1/2" - 6")	4 / 6 / 8	A193 ASTM A193, Gr. B8M (Stainless Steel) A193 ASTM A193, Gr. B7 (Carbon Steel)
17	Nut (1/2" - 1")	4	A194 ASTM A194, Gr. B8M (Stainless Steel) A194 ASTM A194, Gr. B7 (Carbon Steel)
18	Anti Static Device	2	316 Stainless Steel
19	Stop Pin (1/2"-2")	1	304 Stainless Steel
		2	304 Stainless Steel

SERIES 49 VALVE PARTS AND IDENTIFICATION

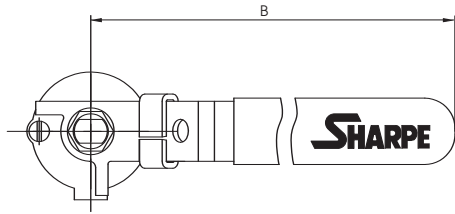

1/2" - 2" Handle

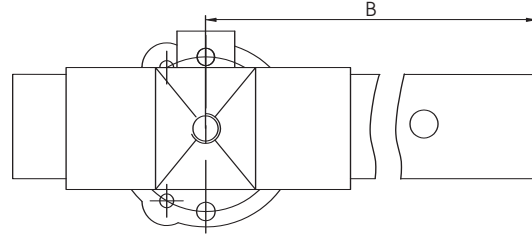

2-1/2" - 6" Pipe Handle

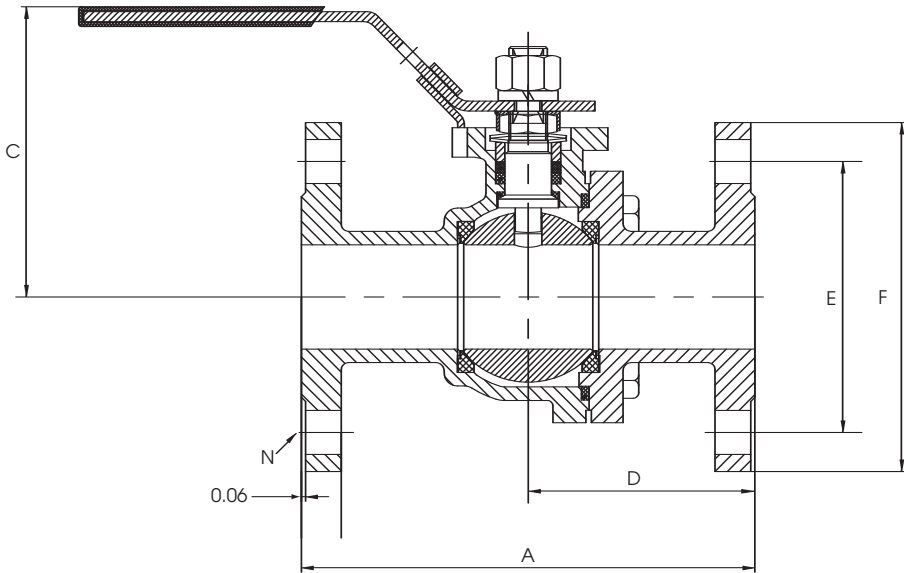

CV DATA

1/2"	26
3/4"	50
1"	94
1-1/2"	260
2"	480
2-1/2"	750
3"	1300
4"	2300
6"	5400

PORT

1/2"	0.59
3/4"	0.78
1"	1.00
1-1/2"	1.50
2"	2.00
2-1/2"	2.55
3"	3.00
4"	4.00
6"	6.00

WEIGHT (lbs.)

1/2"	3.50
3/4"	4.50
1"	6.50
1-1/2"	12.00
2"	18.00
2-1/2"	29.00
3"	36.00
4"	54.00
6"	115.00

CV-The volume of water in Gal./Min. that pass through a given valve with a pressure drop of 1 PSI.

DIMENSION TABLE

SIZE	A	B	C	D	E	F	N
1/2"	4.25	4.65	3.00	2.13	2.38	3.50	4
3/4"	4.62	4.65	3.35	2.32	2.75	3.85	4
1"	5.00	6.18	3.75	2.50	3.13	4.25	4
1-1/2"	6.50	9.13	4.50	3.25	3.56	5.00	4
2"	7.00	9.13	4.80	3.50	4.75	6.00	4
2-1/2"	7.50	13.13	6.70	3.74	5.50	7.00	4
3"	8.00	13.12	7.00	4.00	6.00	7.48	4
4"	9.00	13.12	7.70	4.51	7.50	9.01	8
6"	15.50	25.50	9.45	7.76	9.50	10.98	8

SHARPE® VALVES

Choose from our full line of high quality valves and actuators to meet your needs.

SEAT PRESSURE/TEMPERATURE RATING SERIES 49

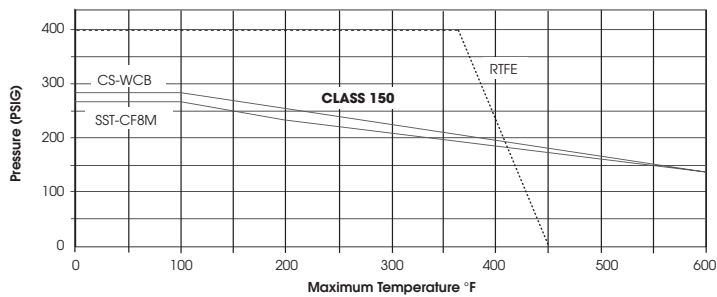

HOW TO ORDER

VALVE SIZE	VALVE SERIES	CLASS	ALLOY	SEATS
1/2" 3/4" 1" 1-1/4" 1-1/2" 2" 2-1/2" 3" 4" 6"	49	150# = 11	4 = Carbon Steel 6 = Stainless Steel	R = RTFE

3/4" 49 11 6 R

SHARPE® VALVES

A Division of Smith-Cooper International, LLC

Toll Free: 1-877-7SHARPE

(877) 774-2773

Fax: (708) 562-9250

Email: info@sharpevalves.com

www.sharpevalves.com

1260 Garnet Drive

Northlake, Illinois 60164 U.S.A.