

# **SHARPE<sup>®</sup> VALVES**

---

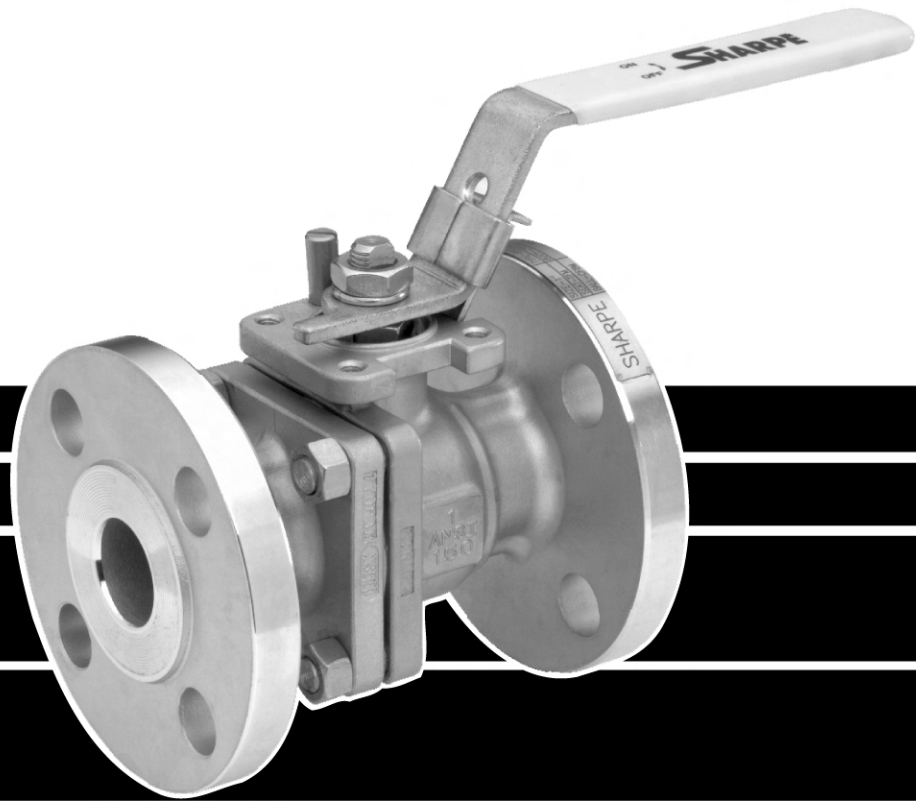

**FLANGED FULL PORT  
BALL VALVE  
SERIES 50 / CLASS 150**

# SERIES 50 VALVE PARTS AND IDENTIFICATION

## CLASS 150 BLOW OUT PROOF STEM LOCKING DEVICE

APPLICABLE STANDARDS	
Wall Thickness	ASME B 16.34
Face to Face Dimensions	ASME B 16.10
Flange Dimensions	ASME B 16.5
Pressure Tests	ASME B 16.34    API 598 (Optional)
Basic Design	ASME B16.34

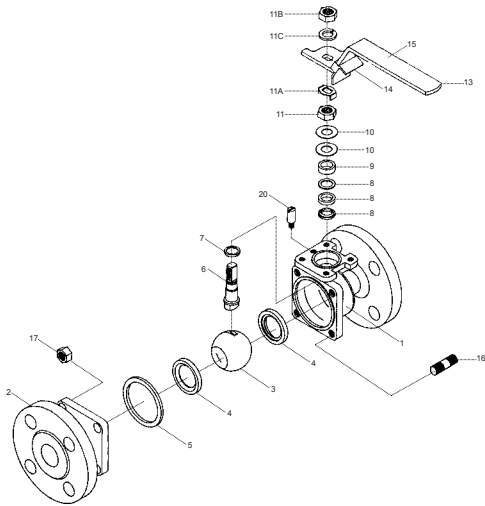

**1/2" - 2"**

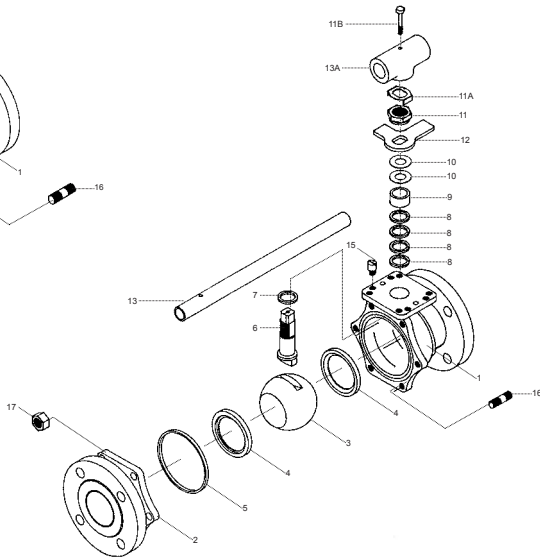

**2-1/2" - 4"**

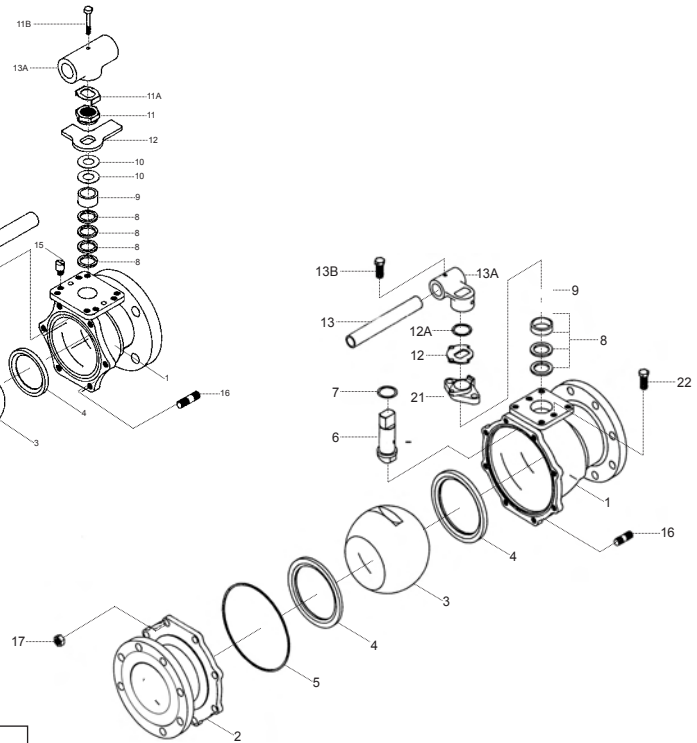

**6" - 8"**

PART NO.	PART	QTY.	MATERIAL
1	Body	1	316 Stainless Steel    ASTM A351 CF8M Alloy 20    ASTM A351 CN7M Carbon Steel    ASTM A216 WCB Hastelloy C    ASTM A494 GR CW-12MW Monel    ASTM A494 GR M35-1
2	End Connector	1	316 Stainless Steel    ASTM A351 CF8M Alloy 20    ASTM A351 CN7M Carbon Steel    ASTM A216 WCB Hastelloy C    ASTM A494 GR CW-12MW Monel    ASTM A494 GR M35-1
3	Ball	1	316 Stainless Steel    Alloy 20    Hastelloy C
4	Seat	2	TFM(Super TFE)    TFE    Reinforced TFE NOVA    PEEK
5	Body Seal	1	TFE
6	Stem	1	316 Stainless Steel    Alloy 20    Hastelloy C 17-4PH (Option)
7	Thrust Bearing	2	Reinforced TFE
8	Stem Packing	3/4	Reinforced TFE
9	Gland Packing	1	304 Stainless Steel
10	Belleville Washer (1/2"-4")	2/4	304 Stainless Steel
11	Packing Nut (1/2"-4")	1	304 Stainless Steel
11A	Lock Tab	1	Stainless Steel
11B	Handle Nut	1	304 Stainless Steel
11C	Lock Washer	1	304 Stainless Steel (1/2"-2")

PART NO.	PART	QTY.	MATERIAL
12	Stopper	1	304 Stainless Steel
12A	Snap Ring	1	Stainless Steel (6"-8")
13	Handle	1	304 Stainless Steel (1/2"-2") Galvanized Steel (2-1/2"-4") Ductile Iron (6"-8")
13A	Wrench Block	1	Stainless Steel
13B	Hex Head Bolt	1	304 Stainless Steel
14	Locking Device (1/2"-2")	1	304 Stainless Steel
15	Sleeve	1	Vinyl
16	Body Stud	SEE* N	A193    B8 (SST) A193    B7 (CS)
17	Nut	SEE* N	A194    8 (SST) A194    2H (CS)
20	Stop Pin (1/2"-2") (2-1/2"-4")	1 2	304 Stainless Steel 304 Stainless Steel
21	Gland Flange (6"-8")	1	304 Stainless Steel
22	Gland Bolts (6"-8")	2	304 Stainless Steel

\*See Dimensions

# SERIES 50 DIMENSIONS

## 1/2" - 2"

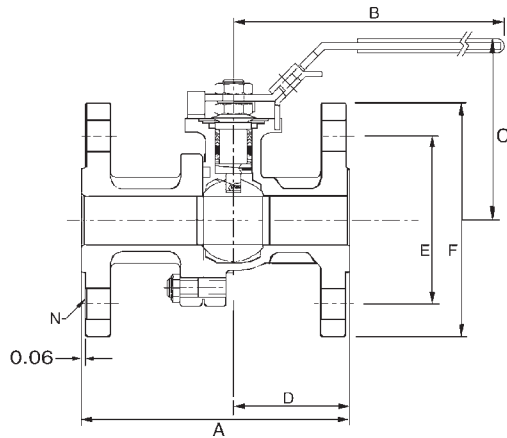

## 2-1/2" - 4"

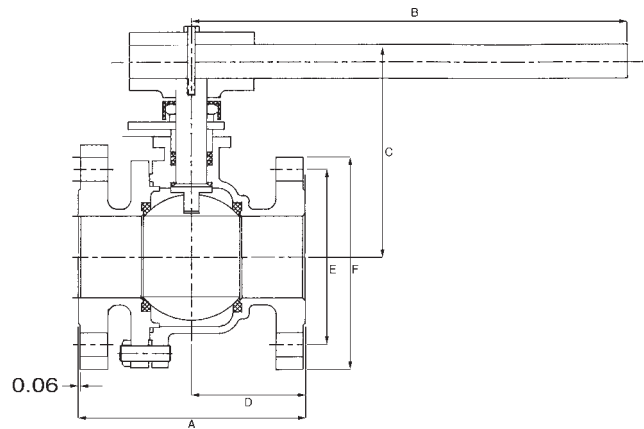

## 6" - 8"

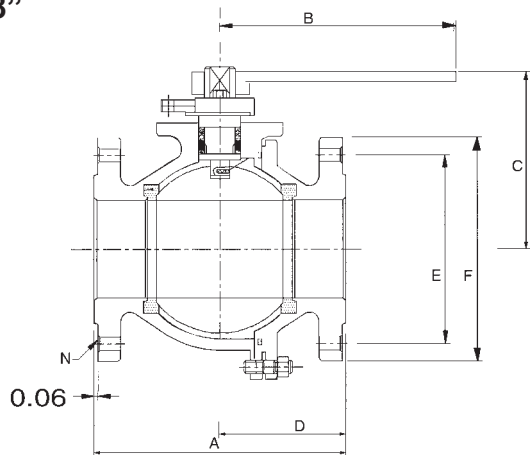

### CV DATA

1/2"	26
3/4"	50
1"	94
1-1/2"	260
2"	480
2-1/2"	750
3"	1300
4"	2300
6"	5400
8"	10000

### PORT

1/2"	0.59
3/4"	0.78
1"	1.00
1-1/2"	1.50
2"	2.00
2-1/2"	2.55
3"	3.00
4"	4.00
6"	6.00
8"	7.88

### WEIGHT (lbs.)

1/2"	4
3/4"	6
1"	8
1-1/2"	15
2"	20
2-1/2"	36
3"	45
4"	75
6"	135
8"	290

SIZE	A	B	C	D	E	F	N	G	H	I	J	K	W
1/2"	4.25	4.75	3.60	1.80	2.38	3.50	4	1.39	3/8-24 UNF	.22	.28	.63	M5
3/4"	4.62	4.75	3.75	2.00	2.75	3.85	4	1.39	3/8-24 UNF	.22	.28	.63	M5
1"	5.00	6.22	3.75	2.12	3.13	4.25	4	1.39	7/16-20 UNF	.30	.30	.90	M6
1-1/2"	6.50	9.00	4.50	2.76	3.56	5.00	4	1.94	9/16-18 UNF	.35	.42	1.18	M8
2"	7.00	9.00	4.80	3.08	4.75	6.00	4	1.94	9/16-18 UNF	.35	.42	1.18	M8
2-1/2"	7.50	13.75	6.70	3.09	5.50	7.00	4	2.84	M20	.55	.55	1.83	M10
3"	8.00	13.75	7.00	3.74	6.00	7.48	4	2.84	1-14 UNS	.745	.66	1.83	M10
4"	9.00	13.75	7.70	4.46	7.50	9.01	8	2.84	1-14 UNS	.745	.66	1.83	M10
6"	15.50	38.97	11.22	7.61	9.50	10.98	8	3.89	1.02	1.64	1.46	3.00	M12
8"	18.00	38.97	11.57	8.34	11.75	13.50	8	4.59	1.02	1.64	1.46	3.00	M12

1/2" - 4"

6" - 8"

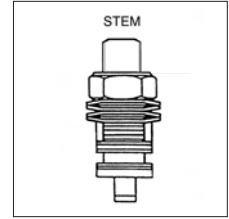
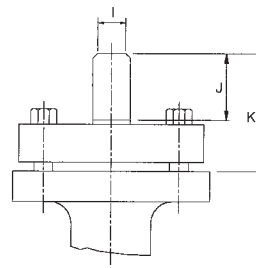
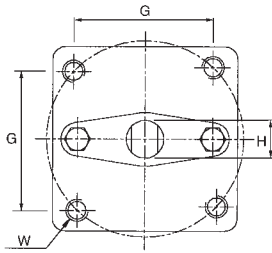
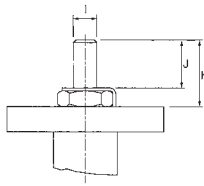
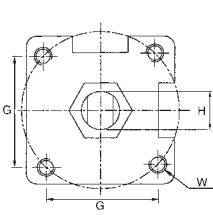

1/2" - 4"  
STEM ARRANGEMENT  
FOR ACTUATORS

### SEAT PRESSURE/TEMPERATURE RATING SERIES 50

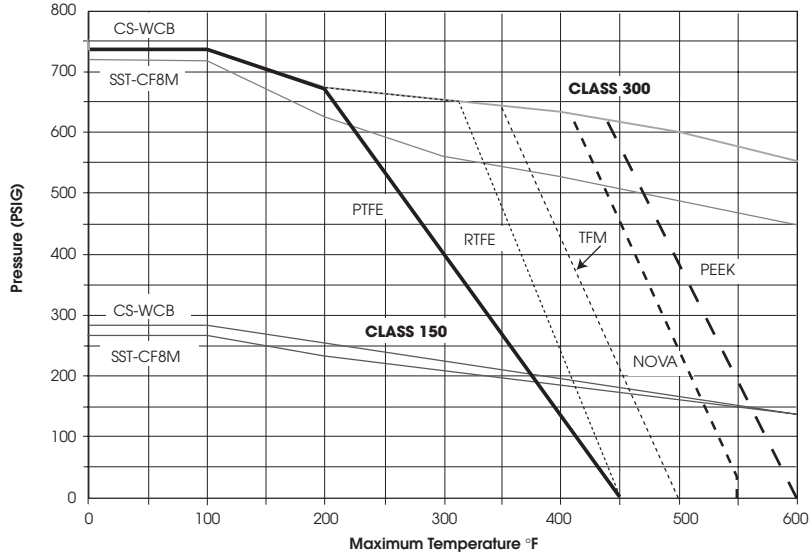

### HOW TO ORDER

VALVE SIZE	VALVE SERIES	CLASS	ALLOY	SEATS	OPTIONS
1/2" 3/4" 1" 1-1/2" 2" 2-1/2" 3" 4" 6" 8"	50	150# = 11	2 = Alloy 20 4 = Carbon Steel 6 = Stainless Steel 5 = Hastelloy C 3 = Monel	T = TFE R = RTFE N = NOVA P = Peek M = TFM™	X = Oxygen Service OH = Oval Handle F = Fugitive Emissions Certified ANSI 593.00.01 E = Extended Stem L = Lockable Extended Stem D = Leak detection Stem GO = Gear Operator 7 = 17- 4PH Stem A = Nace

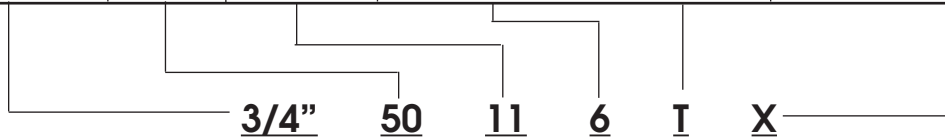

# SHARPE VALVES

A Division of Smith-Cooper International, LLC

Toll-Free 1-877-7SHARPE

(877) 774-2773

Fax: (708) 562-9250

E-Mail: info@sharpevalves.com

www.sharpevalves.com

1260 Garnet Drive

Northlake, Illinois 60164 U.S.A.