

SHARPE[®] VALVES

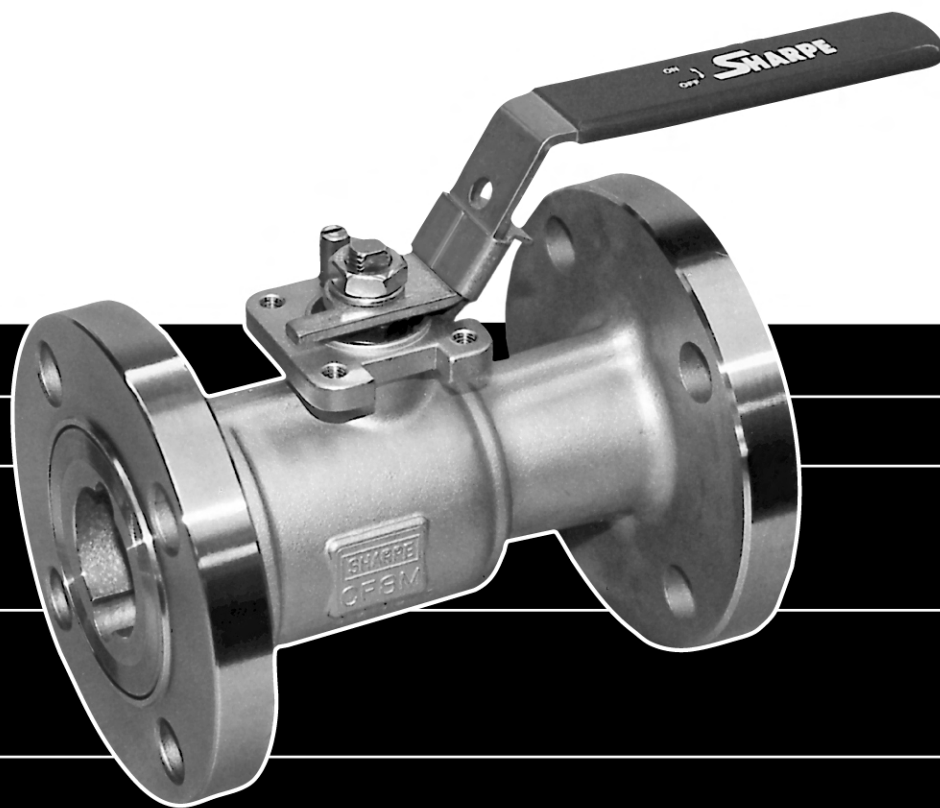

**FLANGED STANDARD PORT
BALL VALVE
SERIES 54 / CLASS 150**

SERIES 54 VALVE PARTS AND IDENTIFICATION

CLASS 150 BLOW OUT PROOF STEM LOCKING DEVICE

APPLICABLE STANDARDS	
Shell Wall Thickness	ASME B 16.34
Face to Face Dimensions	ASME B 16.10
Flange Dimensions	ASME B 16.5
Pressure Testing	ASME B 16.34 API 598 (Optional)
Basic Design	ASME B16.34

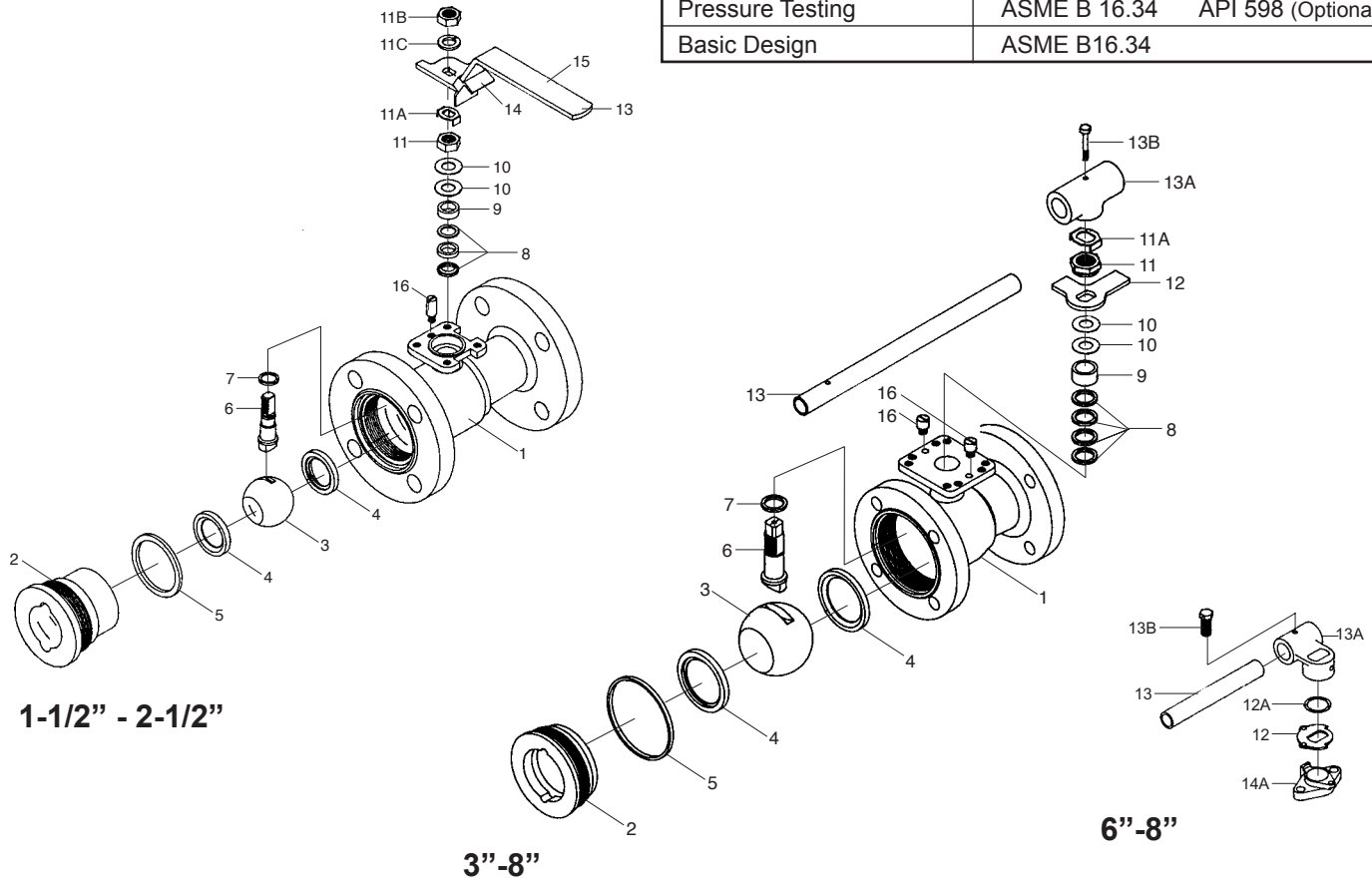

PART NO.	PART	QTY.	MATERIAL
1	Body	1	316 Stainless Steel ASTM A351 CF8M Carbon Steel ASTM A216 WCB Alloy 20 ASTM A351 CN7M Hastelloy C ASTM A494 Type CW-12MW Monel ASTM A494 GR M35-1
2	End Connector	1	316 Stainless Steel ASTM A351 CF8M Carbon Steel ASTM A216 WCB Alloy 20 ASTM A351 CN7M Hastelloy C ASTM A494 Type CW-12MW Monel ASTM A494 GR M35-1
3	Ball	1	316 Stainless Steel Alloy 20 Hastelloy C Monel
4	Seat	2	TFM(Super TFE) TFE Reinforced TFE NOVA
5	Body Seal	1	TFE
6	Stem	1	316 Stainless Steel / Alloy 20 / Hastelloy C / Monel 17-4PH (Option)
7	Thrust Bearing	2	Reinforced TFE
8	Stem Packing	3/4	Reinforced TFE
9	Gland Packing	1	304 Stainless Steel
10	Belleville Washer (1"-4")	2/4	304 Stainless Steel
11	Packing Nut (1"-4")	1	304 Stainless Steel

PART NO.	PART	QTY.	MATERIAL
11A	Lock Tab (1-1/2"-4")	1	Stainless Steel
11B	Handle Nut (1-1/2"-2")	1	304 Stainless Steel
11C	Lock Washer	1	304 Stainless Steel (1-1/2"-2")
12	Stopper	1	304 Stainless Steel
12A	Snap Ring	1	Stainless Steel (6"-8")
13	Handle 3"-8" Lockable Handle	1	304 Stainless Steel (1-1/2"-2") Galvanized Steel (2-1/2"-4") Stainless Steel (3"-4") Ductile Iron (6"-8")
13A	Wrench Block	1	Stainless Steel
13B	Hex Head Bolt	1	304 Stainless Steel
14	Locking Device (1-1/2"-2")	1	304 Stainless Steel
14A	Gland Flange	1	304 Stainless Steel
15	Sleeve	1	Vinyl
16	Stop Pin (1-1/2"-2")	1	304 Stainless Steel
	(2-1/2"-4")	2	304 Stainless Steel

*See Dimensions

SERIES 54 DIMENSIONS

1" - 2-1/2"

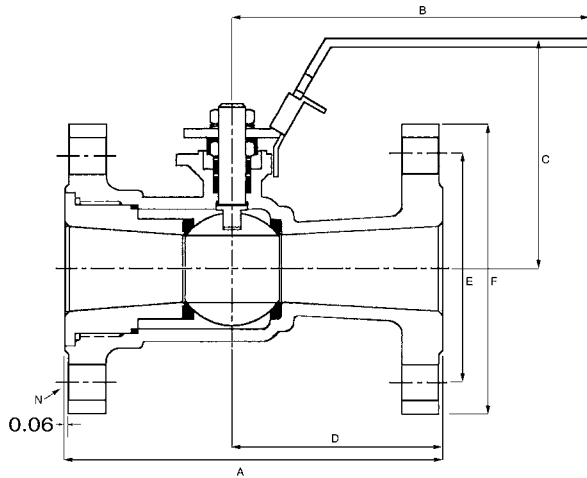

3" - 4"

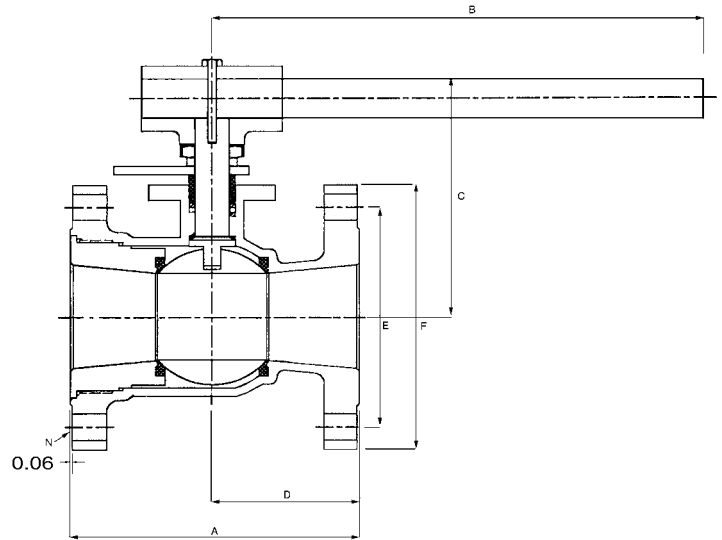

6" - 8"

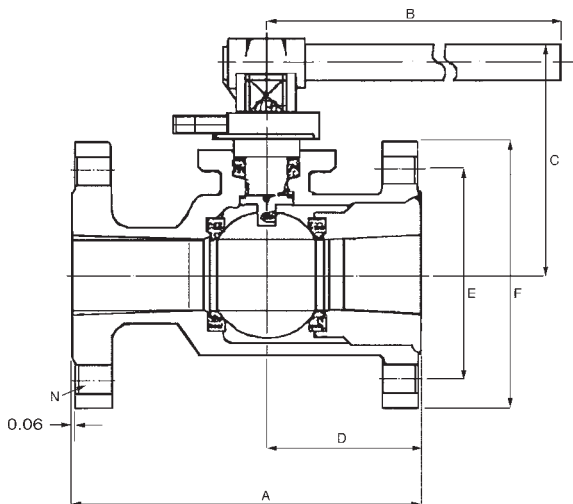

CV* DATA

1"	30
1-1/2"	82
2"	120
2-1/2"	240
3"	350
4"	720
6"	1020
8"	1800

PORT

1"	0.75
1-1/2"	1.25
2"	1.50
2-1/2"	2.00
3"	2.50
4"	3.00
6"	4.00
8"	6.00

WEIGHT (lbs.)

1"	7
1-1/2"	16
2"	17
2-1/2"	26
3"	34
4"	56
6"	122
8"	184

*CV: The volume of water in gal./min. that will pass through a given valve with a pressure drop of 1 PSI.

SIZE	A	B	C	D	E	F	N	G	H	I	J	K	W
1	5.00	4.75	3.60	2.50	3.12	4.25	4	1.39	3/8-24 UNF	0.225	0.30	.73	M6
1-1/2"	6.50	6.30	4.00	3.68	3.56	5.00	4	1.94	9/16-18 UNF	.35	.42	.83	M8
2"	7.00	9.00	4.50	4.45	4.75	6.00	4	1.94	9/16-18 UNF	.35	.42	1.14	M8
2-1/2"	7.50	9.00	6.70	3.98	5.50	7.00	4	2.84	M20	.55	.55	1.14	M10
3"	8.00	13.75	7.00	4.03	6.00	7.48	4	2.84	1-14 UNS	.745	.66	1.83	M10
4"	9.00	13.75	7.70	4.53	7.50	9.01	8	2.84	1-14 UNS	.745	.66	1.83	M10
6"	10.50	15.35	7.75	5.90	9.50	10.98	8	3.89	1.64	1.02	1.46	3.00	M12
8"	11.50	25.60	10.50	5.65	11.75	13.50	8	4.59	1.64	1.02	1.46	3.00	M12

1" - 4"

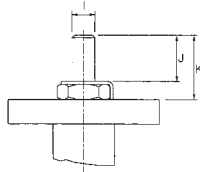
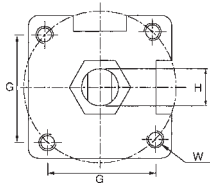

6" - 8"

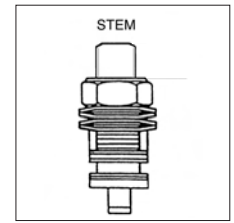
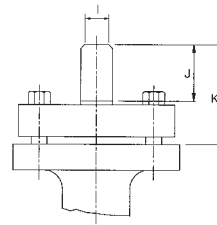
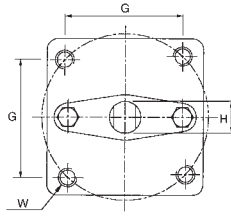

1" - 4"
STEM ARRANGEMENT

SEAT PRESSURE/TEMPERATURE RATING SERIES 54

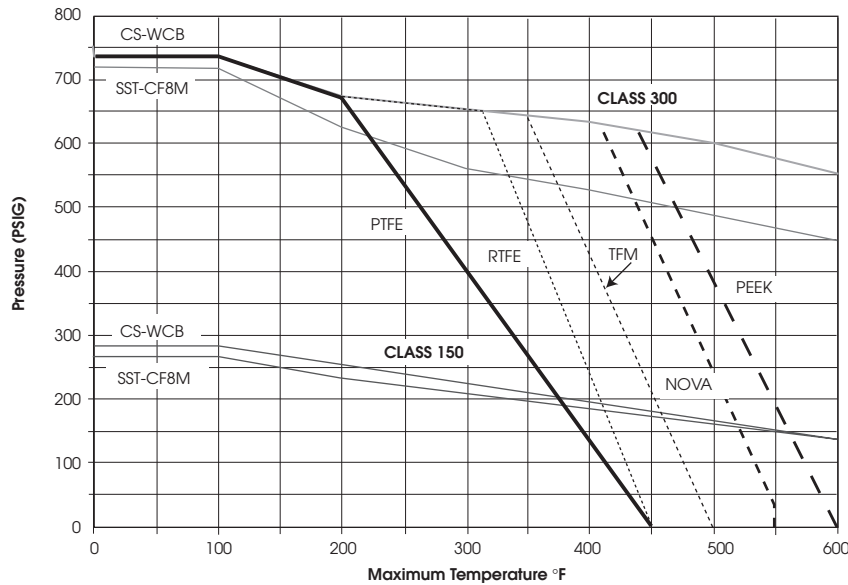

HOW TO ORDER

VALVE SIZE	VALVE SERIES	CLASS	ALLOY	SEATS	OPTIONS
1" 1-1/2" 2" 3" 2-1/2" 4" 6" 8"	54	150# = 11	4 = Carbon Steel 6 = Stainless Steel 2 = Alloy 20 3 = Monel 5 = Hastelloy C	T = TFE R = Reinforced TFE N = NOVA M = TFM™ P = PEEK	X = Oxygen Service OH = Oval Handle F = Fugitive Emissions Certified ANSI 593.00.01 E = Extended Stem L = Lockable Extended Stem D = Leak Detection Stem GO = Gear Operator 7 = 17- 4PH Stem A = Nace

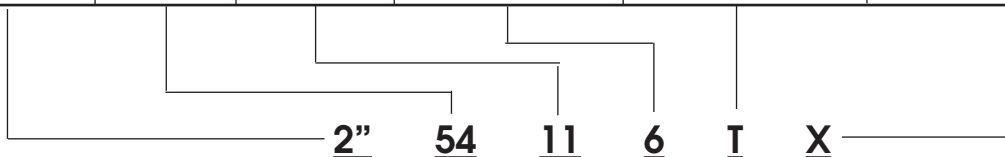

SHARPE VALVES

A Division of Smith-Cooper International, LLC

Toll-Free 1-877-7SHARPE

(877) 774-2773

Fax: (708) 562-9250

E-Mail: info@sharpevalves.com

www.sharpevalves.com

1260 Garnet Drive

Northlake, Illinois 60164 U.S.A.