



Worcester Controls

WCAIM2014
(Part 12224)

1/2" - 2" 51/52 One-piece, Flanged Ball Valves (Includes D, S, W, W2, AF, FZ, PT and CL Series) Installation, Operation and Maintenance Instructions

CAUTION: Flowserve recommends that all product which must be stored prior to installation be stored indoors, in an environment suitable for human occupancy. Do not store product in areas where exposure to: relative humidity above 85%, acid or alkali fumes, radiation above normal background, ultraviolet light, or temperatures above 120°F or below 40°F may occur. Do not store within 50 feet of any source of ozone.

INSTALLATION

Valve may be installed for flow or vacuum in either direction. Use care to exclude pipe sealants from the valve cavity. Valves with upstream relief hole in ball (V3 option) are one-way valves.

Diverter valves (D51) may be installed using the bottom port as the inlet port. The flow can then be diverted to either one of the two side outlet ports.

Note that for CL51/52 valves, the maximum pressure rating is 300 psi per the Chlorine Institute. The Chlorine Institute recommends that the relief hole in the ball be upstream, toward the pressure source. An arrow stamped on the body or on a metal tag welded to the body indicates flow path.

When installing, use standard gaskets suitable for the specific service. Tighten flange bolts or studs evenly.

OPERATION

The operation consists of turning the handle and/or stem 1/4 turn clockwise to close. The valve is open when the handle and/or stem flats are in-line with the pipeline. These valves may also be automated.

These valves will provide bubble-tight shutoff when used in accordance with the Worcester's published pressure/temperature chart. Valves with "G" seats meet the leakage rates of ANSI B16.104 Class VI.

The diverter valve will allow no leakage through the closed outlet port when used as described with the bottom port as the inlet.

The porting one (V1) style valve is operated by turning the handle one quarter-turn to change selection of sources. With this style of valve the flow is never stopped and some mixing of the media is possible. This valve is easily automated with a pneumatic or electric actuator.

The porting two (V2) style valve is operated by turning the handle one half turn to direct the flow from one side to the other. With this style valve the flow is stopped in the 90° position. (There is no stop in this position.) This valve may be automated with an electric actuator only.

It is not good practice to leave ball valves partially open (throttling operation) without knowledge of the pressure drop and flow at that position.

As shipped from the factory, valves (except CL Series oxygen prepared (V20, V33 or prefix code "X") and valves with V38 or V46 option) contain a silicone-based lubricant. This is for break-in purposes, and may be removed, if it is objectionable for a particular application, by disassembling and solvent washing. Lacquer thinner will remove the lubricant. "A" or "G" (filled metal) seated valves should not be operated without a break-in lubricant.

Media which can solidify, crystallize or polymerize should not be allowed to stand in ball cavities.

Torque Requirements: Operating torque requirements will vary depending on the length of time between cycles, line pressure, type of valve seats, and the media in the system. For a detailed analysis of valve torque requirements, see Worcester's Actuator Sizing Manual.

NOTE: Media which contain fine powders (25 microns or less) will significantly raise ball valve torque requirements.

CAUTIONS: The fluoropolymer and UHMWPE body seals (codes T and U) and the coated stainless steel gaskets (codes M and G) make excellent seals. However, some points of caution in their use need emphasizing.

No fluoropolymer or UHMWPE part (except seats) or seat back seal is reusable. Coated stainless steel gaskets are also not reusable. Upon disassembly of the valve, they should be discarded and replaced with new parts.

Care must be taken to avoid scratching the fluoropolymer or UHMWPE seals, or the coating of the gaskets during installation. Light lubrication of these seals can help prevent damage.

Care must also be taken when handling a graphite thrust bearing, stem seal, or seat back seal. These parts can be easily damaged by squeezing the OD of the seal. Parts are to be handled on the flat surfaces rather than the OD.

The ball used in valves with "A" and "G" (filled metal) seats is round to special tolerances. To ensure proper contact with the seat, do not drop, dent or scratch the ball during handling. These balls also have an anti-galling coating. DO NOT use uncoated balls with filled metal seats.

MAINTENANCE

If seepage is noted at stem, tighten retaining nut per the following steps.

CAUTION: For maximum stem seal life, proper stem adjustment procedure must be followed.

Excessive tightening causes higher torque and shorter stem seal life.

For CL51/52 valves only, immediately after the first frost is detected around the stem, tighten the retaining or self-locking nut, as stated below, to adjust the compression of the stem seals.

For Valves with Two Stem Nuts and a Lockwasher (with or without handle):

Tighten retaining nut (lower nut) until Belleville washers are flat, the nut will "bottom".

Back off retaining nut 1/8 turn.

Tighten handle nut securely to lock retaining nut in place. (On some automated valves, two retaining nuts are used with a lockwasher in between. Hold the bottom nut securely with a wrench while tightening the top nut to lock the two nuts in place.)

For Valves with Self-Locking Stem Nut (and four Belleville washers):

Tighten self-locking stem nut until Belleville washers are flat, the nut will "bottom".

Back off nut 1/8 turn.

CAUTION: The self-locking stem nut is difficult to tighten, and must fully flatten Belleville washers before backing off.

REBUILDING

▲ WARNING: BALL VALVES CAN TRAP PRESSURIZED FLUIDS IN BALL CAVITY WHEN CLOSED

Special handling and cleaning procedures are necessary for oxygen and vacuum service valves. Refer to industry practices when overhauling these units

If the valve has been used to control hazardous media, it must be decontaminated before disassembly. It is recommended that the following steps are taken for safe removal and disassembly.

Relieve the line pressure. Operate the valve prior to attempting removal from line.

Place valve in half-open position and flush the line to remove any hazardous material from valve.

For CL51/52 valves, refer to Chlorine Institute Pamphlet 6 procedure for flushing and drying, and for additional information on precautions and cleaning.

All persons involved in the removal and disassembly of the valve should wear the proper protective clothing such as face shield, gloves, apron, etc.

A standard repair kit may be ordered for the valve. Specify the size, series, material of seats and body seal and R# (revision number) of valve or for non-standard valve, the "P"-Number, "T"-Number, "C"-Number, or similar as found on nameplate. Some series, such as FZ, S, AF, W, W2, and CL have their own repair kits, which are ordered by the prefix. If valve body is stainless steel, place a "6" after valve size in repair kit ordering code.

Examples:

Valve Size	Prefix (if required)	RK	Series 51	Material	Rev. # or P, T, C, etc. #
1"	AF	RK	51	RT	R3
3/4"	6	RK	51	PM	R5
1/2"		RK	51	RT	T0914
1/2"	W				
		RK	52	XM	R3

Disassembly of Valve:

Remove valve from line. Unscrew end plug and set aside. If the body seal was not removed with the end plug, remove it from the valve and discard. Remove and discard the near seat and seat back seal (if any). Place valve in closed position and remove the ball.

NOTE: If required, end plug disassembly tools are available from your supplier or from Flowserve.

Removing Stem Assembly

Remove handle nut, lockwasher, also separate handle and stop or one-piece handle/stop (if manual valve). (This step is not applicable to valves with self-locking stem nut.)

Remove retaining or self-locking stem nut. Prevent stem from turning with wrench.

Remove and discard Belleville washers. Push stem into ball cavity and remove. On the ½" size, the far seat must be removed before pushing stem into cavity.

Remove and discard stem seal(s), stem seal protector (if any), thrust bearing, and thrust bearing protector (if any), which may be on the stem or in the body stem cavity. Remove and discard the far seat and the seat seal (if any). Retain the follower.

Visual Inspection:

The ball and the surfaces against which the seats and seals are installed should be undamaged, clean and free of pit marks and scratches. Light marring from the action of the ball against the seats is normal and will not affect the operation of the valve. Flaws which can be seen but barely detected with finger tips are acceptable.

The stem and body surfaces that the thrust bearing(s) and stem seal(s) contact, must be undamaged, clean and free of pit marks and scratches.

Reassembly

NOTE: Valves with a pressure relief hole in the ball (V3 option and chlorine valve) must be reassembled and installed with the hole upstream (end plug side) to ensure that cavity relief is upstream when valve is closed. Any valve with a relief hole will have an arrow on the body pointing downstream. This arrow is stamped on the body or on a metal tag welded to the body.

Lightly lubricate the ball, seats, body seal, stem seal(s), stem seal protector and seat back seals (if any), thrust bearing, and thrust bearing protector (if any), with a lubricant compatible with the media being handled, except for valves with V20, V33, or V38 options, which are assembled dry. White petroleum jelly is a good general purpose lubricant.

For valve repair kits with "A" or "G" seats, the filled metal seats will be lubricated at the factory. If they are not, they should be lubricated as noted in Paragraph B.5. and also as stated above. DO NOT operate a newly rebuilt valve using filled metal seats without lubricants. The seat back seals will be pre-assembled to the seat backs.

For CL51/52, and oxygen prepared (prefix code "X") valves only, lightly lubricate the ball, seats/body seals, stem seal and thrust bearing with a PTFE-based lubricant such as Fluorolube S-30 or equivalent.

On all except the ½" size, install the far seat and seat back seal (if any) in the body cavity.

The seat should appear to sit flat into the back of the cavity indicating that the seat back seal is properly located on the seat. If the seat back seal is not correctly positioned it could be damaged or cause the valve to leak.

For stem area rebuilding, refer to exploded view and also the stem build illustrations and stem component color chart on the following pages that pertain to the valve being rebuilt.

Order of Assembly:

Place new thrust bearing(s) on stem and insert assembly through body cavity. Place new stem seal(s), stem seal protector (if any), and the follower in position. PEEK thrust bearing and stem seal protectors are placed outside of seals and bearings. The seals/bearings must contact the body.

NOTE: For valves having graphite stem seal(s), care must be taken when installing the graphite parts because they are easily damaged by squeezing the OD of the seals. Handle gently by holding seal(s) on flat surfaces rather than on the OD. If resistance is encountered when installing seal(s) over the stem, use follower to gently push the stem seal(s) down.

Stem seals, stem seal protectors and thrust bearings that are the same size and color are interchangeable.

Place two new Belleville washers in position with the larger diameter sides touching each other.

For those valves with single-locking stem nut, place four new Belleville washers in position (two pairs of washers with larger diameter sides touching each other).

Place retaining or self-locking stem nut on stem and using handle or a wrench to prevent rotation, tighten nut to make snug and firm. Follow section C, Maintenance, for proper stem adjustment.

Replace separate stop and handle or one-piece handle and stop (if manual valve), lockwasher and handle nut on stem. (This step is not applicable to valves with self-locking stem nut.)

Install far seat and seat back seal (if any) (½" valves only), ball (see Note below), body seal, second seat and seat back seal (if any) and end plug. When end plug and body are metal-to-metal, end plug face may project up to .009" beyond surrounding serrated surface. End plug must be fully tightened against machined step in body. If in doubt, assemble end plug without seat and seal, make a witness mark, and reassemble the full assembly.

NOTE: For diverter valves, install ball as follows:

V1 (90° Valves) – With handle and/or stem flats in-line with body main axis, viewed from end plug side (normally upstream) one ball port is to the right, one is down, and the other is on opposite end of valve.

V2 (180° Valves) – Using same convention as V1, one ball port is down and other is on opposite end of valve.

For valves with coated stainless steel "S" gasket, install with the wide flange facing the ball (see view A-A on page 4). Be sure the body seal is well lubricated.

CAUTION: If the seats and seals installed differ from those removed, the valve nameplate or stop must be replaced or remarked to indicate the altered materials and ratings, or valve tagged to so indicate.

When ordering parts, please provide the part name and following information as found on the valve nameplate:

1. Valve size, style and revision number:
e.g., ½" – 5146T 150 R2 Ball
2. Valve size, style and five-character code, known as a "P-Number", "T-Number," "C-Number", or similar, the designation for a non-standard product:
e.g., ½" 5266 RT 300 P3790 Stem

3. Porting (if a diverter valve) must also be specified when ordering these parts:

e.g., 2" D5166 T 150 V1 R6 Ball

The terminology shown in the following exploded view parts listing is standard. Please use when ordering parts.

Item	Qty	Description
1	1	Body
2	1	Nameplate
3	1	Stem
4	1	Thrust Bearing
5	1	Ball
6	2	Seat
7	1	Body Seal
8a	1	End Plug (½" - 1")
8b	1	End Plug (1½" - 2")
9	1 or 2	Stop Pin (Manual Valve Only)
10	1 or 2	Stem Seal (See Part D.3.c.)
11	1	Follower
12	2 or 4	Belleville Washer (See Part D.3.d.)
13	2	Retaining Nut
14	1	Lockwasher
15	1	Handle (Manual Valve Only)
16	1	Self-Locking Stem Nut (Automated Valve Only)
17	1	Stem Seal Protector
18	1	Thrust Bearing Protector

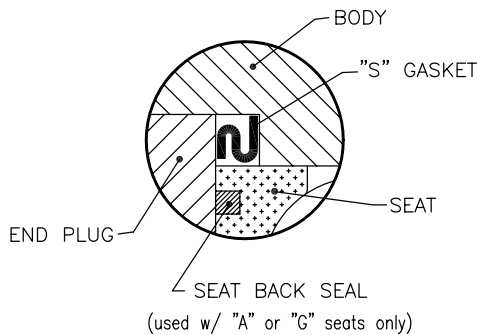

View A-A

1½" – 2" Size Valves Shown

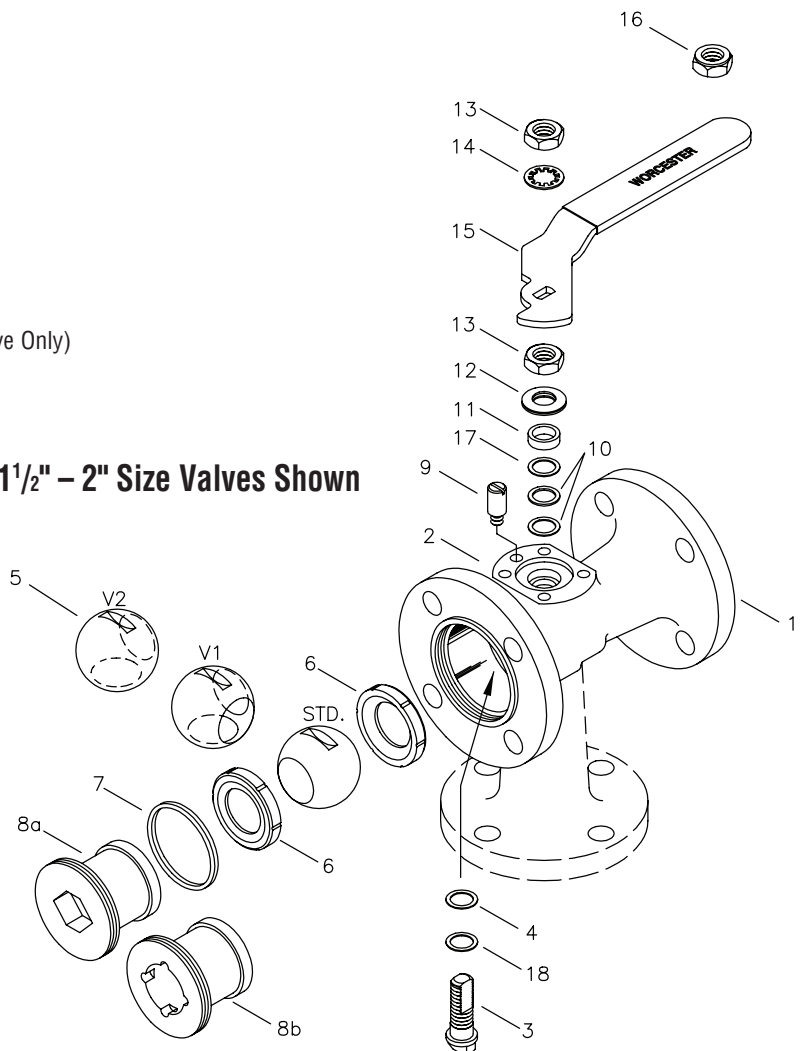

New Style 51/52 Valve Stem Builds

Automated Valve Shown

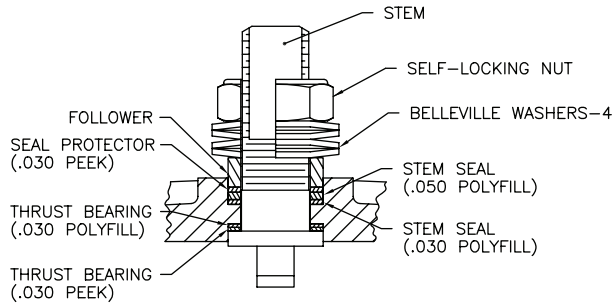

Manual Valve Shown

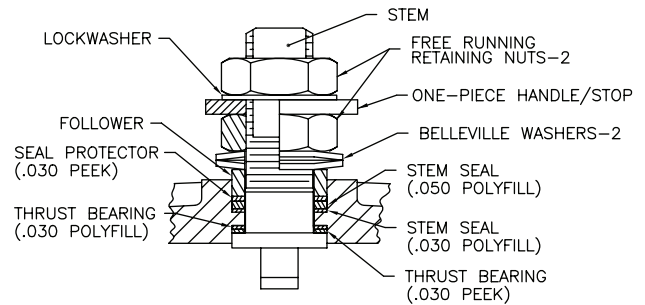

The above stem builds are for all 51/52 series new style valves — Except for those shown below

PT Series Valves with High-Per Fill "X" Seats Automated Valve Shown

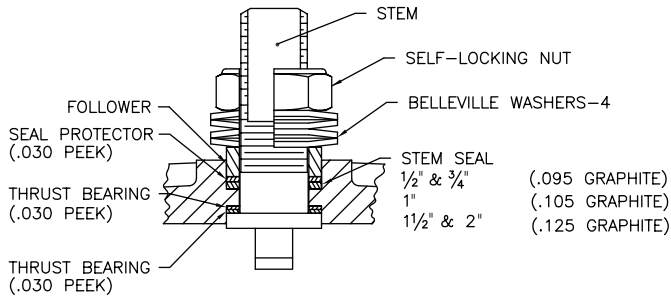

All Other Valves with High-Per Fill "X" Seats Automated Valve Shown

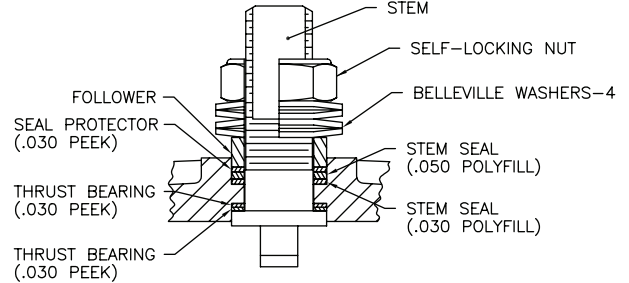

V17 Option — Automated Valve Shown

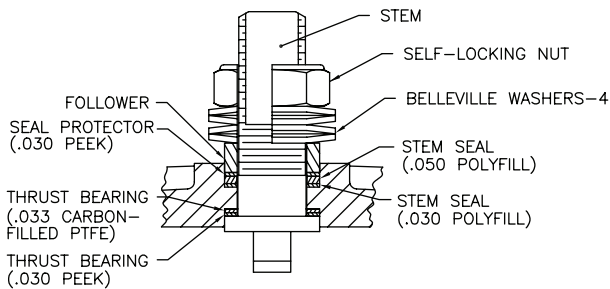

Fire Valve — Automated Valve Shown

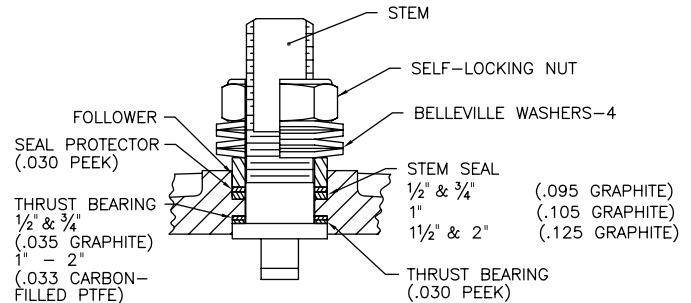

NOTE: Manual valve stem build components such as stem seal(s), thrust bearings and seal protector are the same as automated valves. For colors of various stem components, see color chart on page 6. For fire valves and valves with V17 option used in oxygen service, use Polyfill stem seal and thrust bearing protectors in place of PEEK material.

New Style 51/52 Valve Stem Builds, continued

**Valves with UHMWPE “U” Seats
Automated Valve Shown**

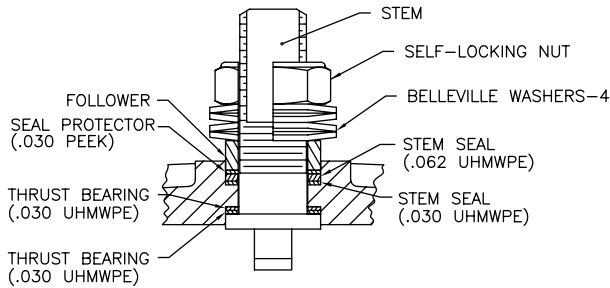

**Oxygen Service Valves with UHMWPE “U” Seats
Automated Valve Shown**

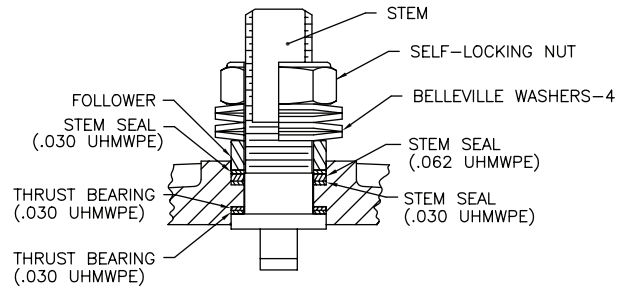

**CL Series and Oxygen Service Valves
Automated Valve Shown**

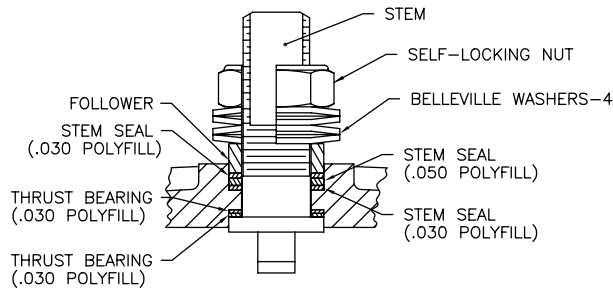

NOTE: Manual valve stem build components such as stem seal(s), thrust bearings and seal protector are the same as automated valves. For colors of various stem components, see color chart below.

Color Chart for Various Stem Component Materials

Material	Color
Polyfill	Black
PEEK	Tan
Graphite	Silver Gray
Carbon-Filled PTFE	Black
UHMWPE	Opaque White
Delrin	Brown
Filled TFE	Off-White

Old Style 51/52 Valve Stem Builds

V51 High-Cycle Option for Automated Valves

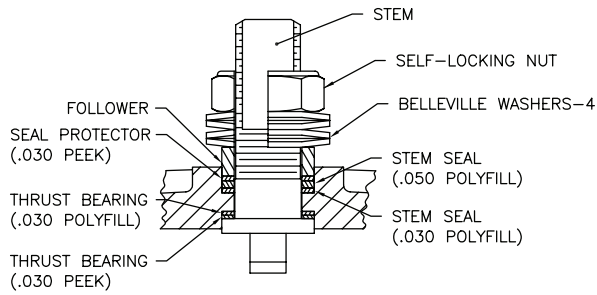

Standard 51/52 Manual Valve Including PT Series with "A" or "G" Seats and CL Series

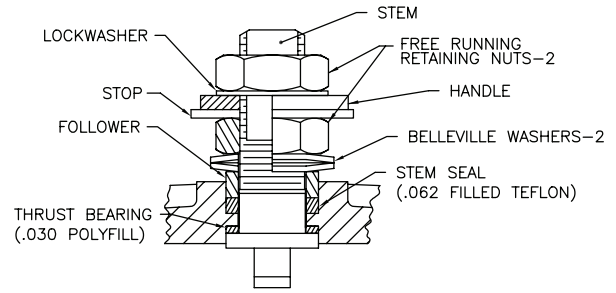

Valves with UHMWPE "U" Seats Automated Valve Shown

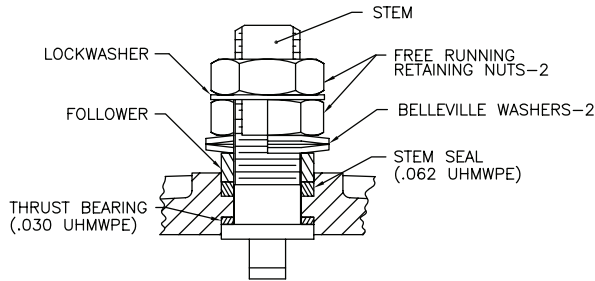

PT Series with High-Per Fill "X" Seats Automated Valve Shown

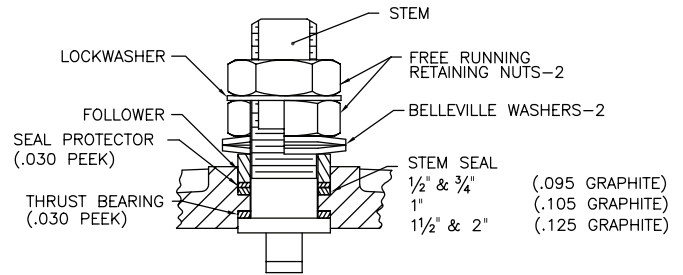

Fire Valve Automated Valve Shown

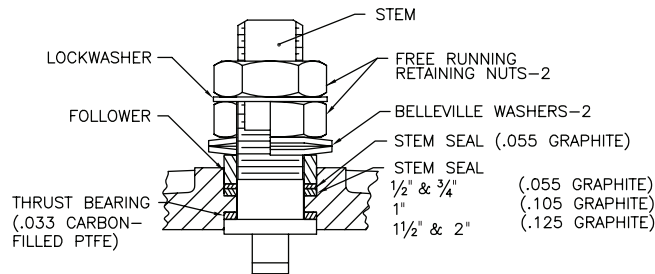

NOTE: Stem build components such as stem seal(s), thrust bearings and seal protector (if used) are the same for manual and automated valves. For colors of various stem components, see color chart on page 6.

Flowserve Corporation has established industry leadership in the design and manufacture of its products. When properly selected, this Flowserve product is designed to perform its intended function safely during its useful life. However, the purchaser or user of Flowserve products should be aware that Flowserve products might be used in numerous applications under a wide variety of industrial service conditions. Although Flowserve can (and often does) provide general guidelines, it cannot provide specific data and warnings for all possible applications. The purchaser/user must therefore assume the ultimate responsibility for the proper sizing and selection, installation, operation, and maintenance of Flowserve products. The purchaser/user should read and understand the Installation Operation Maintenance (IOM) instructions included with the product, and train its employees and contractors in the safe use of Flowserve products in connection with the specific application.

While the information and specifications contained in this literature are believed to be accurate, they are supplied for informative purposes only and should not be considered certified or as a guarantee of satisfactory results by reliance thereon. Nothing contained herein is to be construed as a warranty or guarantee, express or implied, regarding any matter with respect to this product. Because Flowserve is continually improving and upgrading its product design, the specifications, dimensions and information contained herein are subject to change without notice. Should any question arise concerning these provisions, the purchaser/user should contact Flowserve Corporation at any one of its worldwide operations or offices.

For more information about Flowserve Corporation, contact www.flowserve.com or call USA 1-800-225-6989.

FLOWSERVE CORPORATION
FLOW CONTROL DIVISION
1978 Foreman Drive
Cookeville, Tennessee 38501 USA
Phone: 931 432 4021
Facsimile: 931 432 3105
www.flowserve.com