

SHARPE[®] VALVES



SERIES 76
3 WAY BALL VALVES

SERIES 76 VALVE PARTS AND IDENTIFICATION

LIVE LOADED STEM PACKING
 BLOW OUT PROOF STEM
 ISO 5211 MOUNTING PAD
 AVAILABLE IN L OR T PORT CONFIGURATIONS
 4 SEAT DESIGN SECURELY SUPPORTS THE BALL AND PRO-
 VIDES
 POSITIVE SHUTOFF AT ANY CLOSED PORT
 LOCKABLE HANDLE
 1000 WOG
 THREADED ENDS ASME TO B16.11

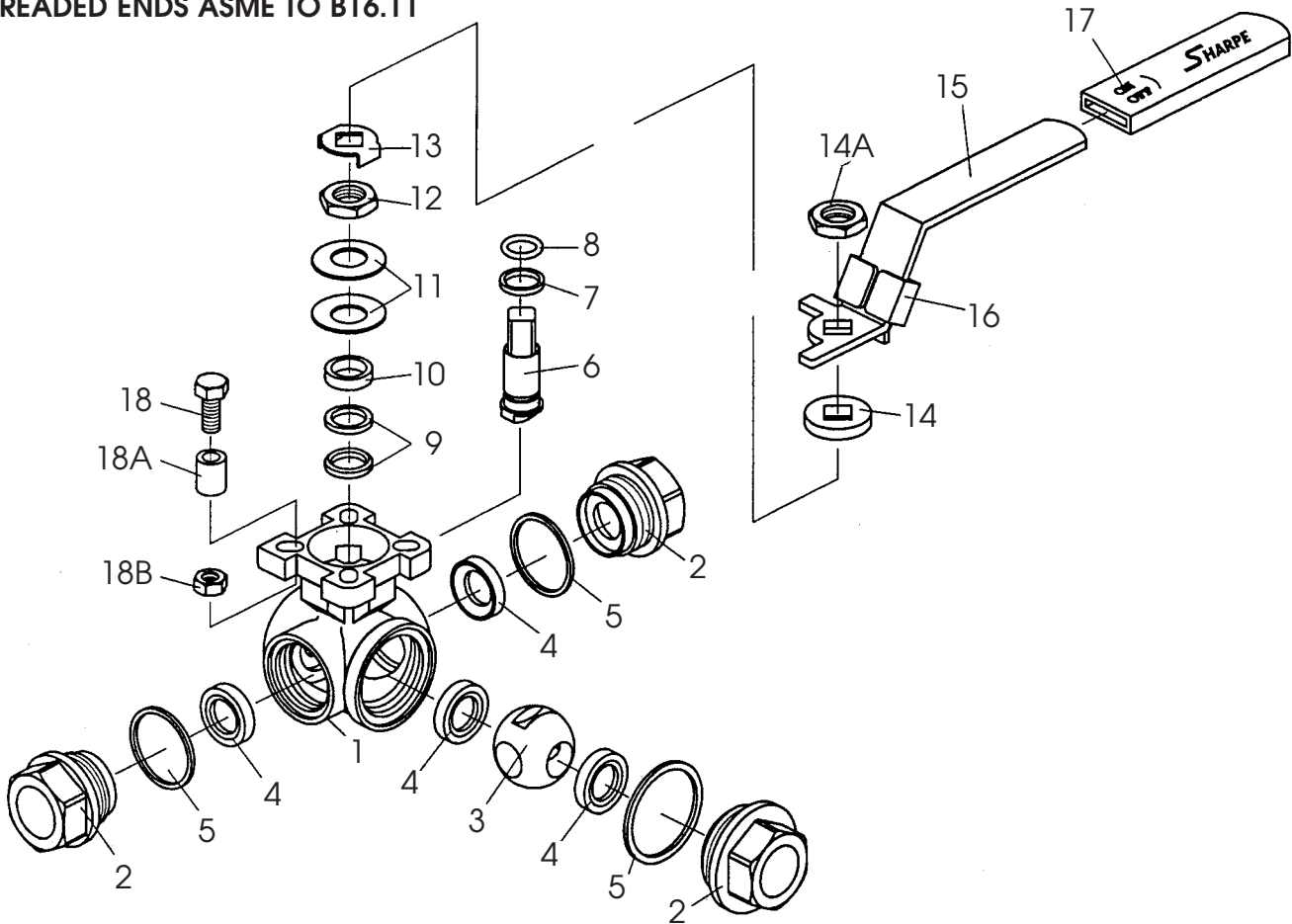

PART NO.	PART	QTY.	MATERIAL
1	Body	1	316 Stainless Steel ASTM A-351 CF8M
2	Ends	3	316 Stainless Steel ASTM A-351 CF8M
3	Ball	1	316 Stainless Steel ASTM A-351 CF8M
4	Seat	4	TFM
5	Body Seal	3	PTFE
6	Stem	1	316 Stainless Steel
7	Thrust Washer	1	PTFE
8	O-Ring	1	Viton
9	Stem Packing	2	PTFE
10	Gland Packing	1	304 Stainless Steel
11	Belleville Washers	2	301 Stainless Steel

PART NO.	PART	QTY.	MATERIAL
12	Stem Nut	1	304 Stainless Steel
13	Lock Tab	1	304 Stainless Steel
14	Washer	1	304 Stainless Steel
14A	Handle Nut	1	304 Stainless Steel
15	Handle	1	304 Stainless Steel
16	Locking Device	1	304 Stainless Steel
17	Handle Sleeve	1	Vinyl
18	Stopper	1	304 Stainless Steel
18A	Stopper Sleeve	1	304 Stainless Steel
18B	Stopper Nut	1	304 Stainless Steel

SERIES 76

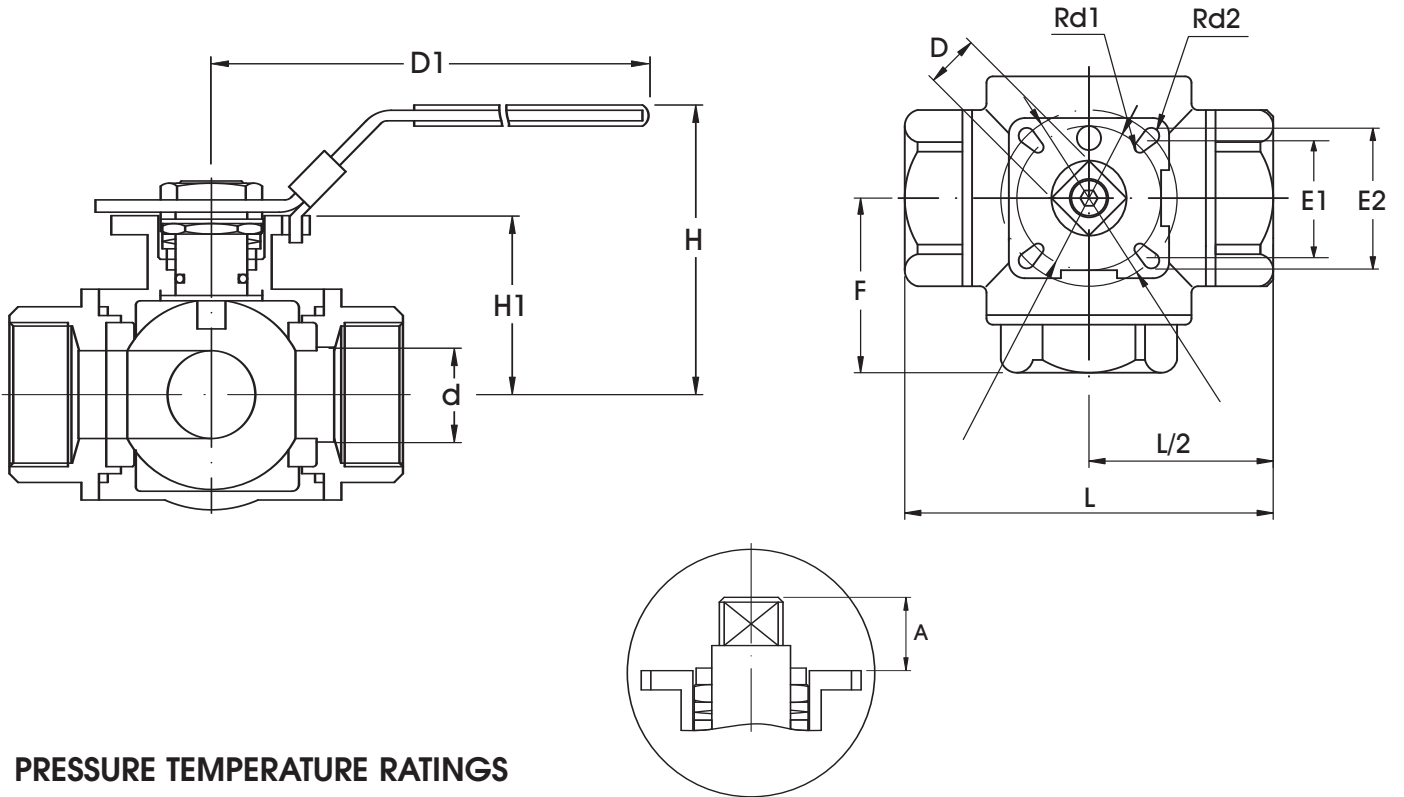

PRESSURE TEMPERATURE RATINGS

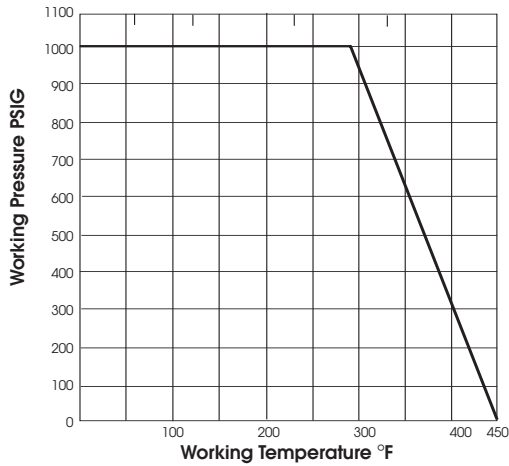

CV DATA*

VALVE SIZE	T PORT	L PORT
1/4"	6	5
3/8"	6	5
1/2"	12	11
3/4"	16	14
1"	20	18
1-1/4"	46	43
1-1/2"	88	84
2"	98	90

* U.S. Gallon per minute.

TORQUE DATA

VALVE SIZE	KG/CM	IN / LBS.
1/4"	40	35
3/8"	40	35
1/2"	50	43
3/4"	65	56
1"	115	100
1-1/4"	210	182
1-1/2"	260	226
2"	430	373

WEIGHTS

VALVE SIZE	LBS.
1/4"	1.65
3/8"	1.65
1/2"	1.65
3/4"	2.40
1"	3.70
1-1/4"	5.40
1-1/2"	8.00
2"	12.80

SIZE	d	L	H	D1	A	D	F	Rd1	Rd2	H1	E1	E2
1/4"	0.43	2.98	3.05	4.41	0.32	0.35	1.47	0.24	0.24	1.60	1.00	1.17
3/8"	0.43	2.98	3.05	4.41	0.32	0.35	1.47	0.24	0.24	1.60	1.00	1.17
1/2"	0.50	2.98	3.05	4.41	0.32	0.35	1.47	0.24	0.24	1.60	1.00	1.17
3/4"	0.63	3.41	3.23	4.41	0.35	0.35	1.76	0.24	0.28	1.78	1.00	1.17
1"	0.79	4.03	3.69	5.37	0.51	0.43	2.02	0.24	0.28	2.22	1.17	1.39
1-1/4"	0.98	4.65	3.98	7.40	0.51	0.43	2.27	0.28	0.36	2.44	1.17	1.39
1-1/2"	1.26	4.95	4.73	7.78	0.65	0.55	2.47	0.28	0.36	2.89	1.39	1.95
2"	1.50	5.87	5.11	7.78	0.65	0.55	2.94	0.36	0.45	3.44	1.39	1.95

T-PORT 90° TURN

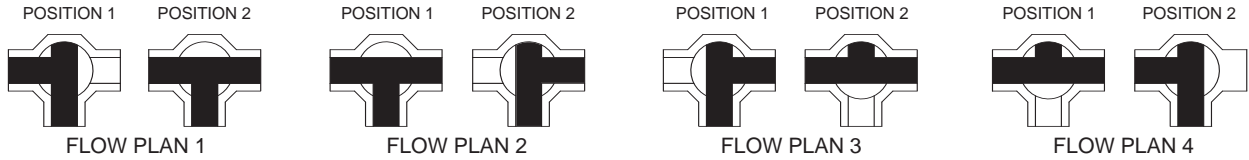

T-PORT 180° TURN

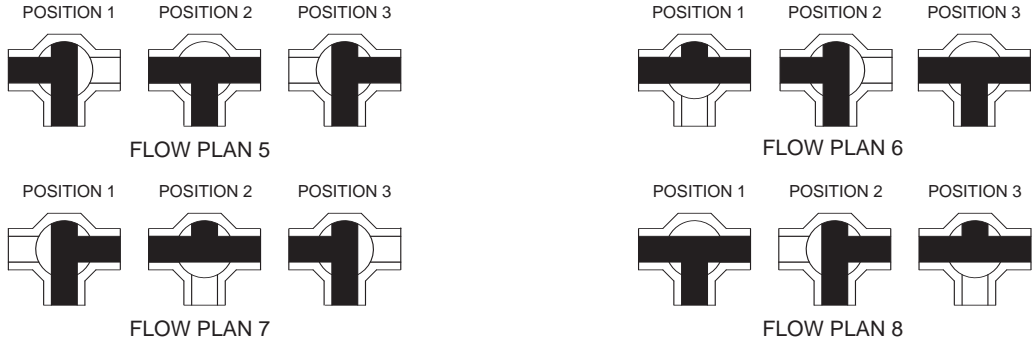

L - PORT 90° TURN

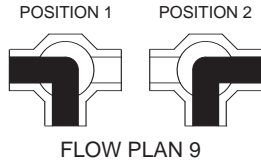

L - PORT 180° TURN

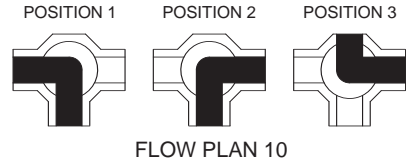

HOW TO ORDER

SIZE	SERIES	BODY	BALL & STEM	SEAT	FLOW PLAN	OPTIONS
1/4" 3/8" 1/2" 3/4" 1" 1-1/4" 1-1/2" 2"	76	6 = 316 Stainless Steel	6 = 316 Stainless Steel	M = TFM (Super TFE)	1 2 3 4 5 6 7 8 9 10	SW = Socket Weld GO = Gear Operator OH = Oval Handle

1" 76 6 6 M 3 GO

SHARPE VALVES
A Division of Smith-Cooper International, LLC

Toll Free: 1-877-7SHARPE
(877) 774-2773
Fax: (708) 562-9250
Email: info@sharpevalves.com
www.sharpevalves.com
1260 Garnet Drive
Northlake, Illinois 60164 U.S.A.