

SHARPE[®] VALVES

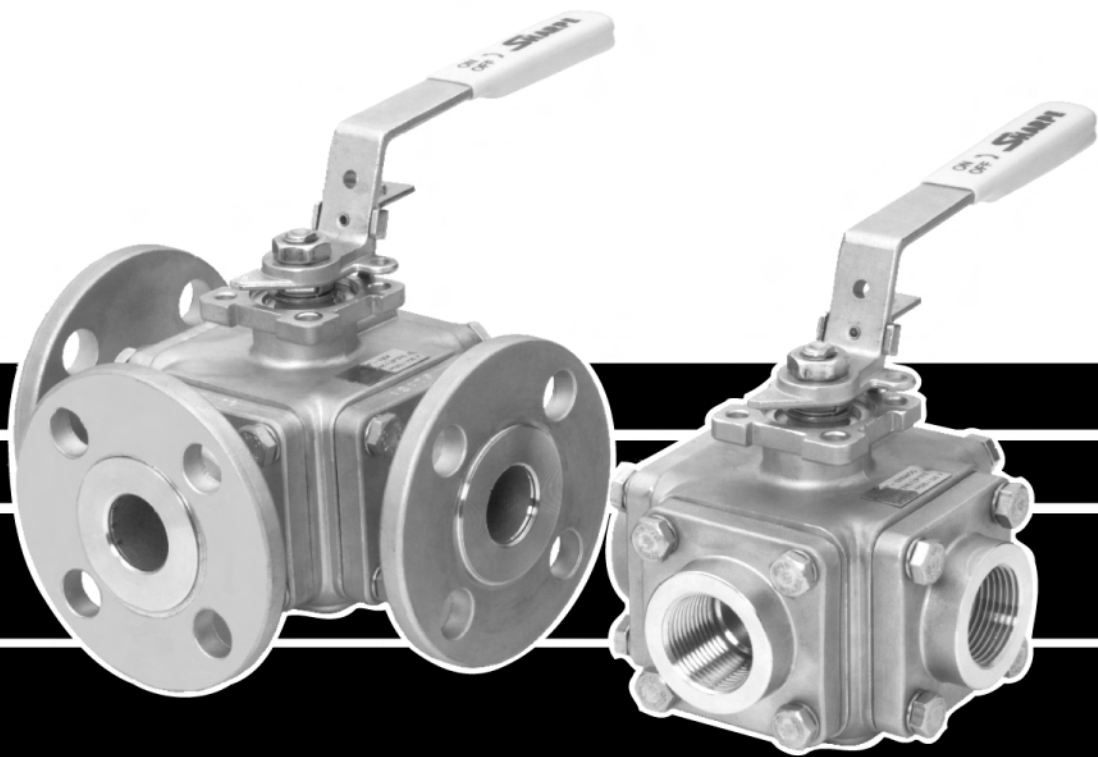

**SERIES 77
HIGH PERFORMANCE
3 & 4 WAY BALL VALVES**

SHARPE® HIGH PERFORMANCE VALVES

Sharpe® 77 - 3 & 4 Way Ball Valves offer as standard features, advantages that other valve manufacturers offer only as costly extras. This is the Sharpe® advantage.

STANDARD FEATURES

ADVANTAGES

Multiport Configurations

The Sharpe Series 77 Valves are ideal choices for many piping designs involving diverting or mixing. In certain applications a single Series 77 valve can replace two, three, or four 2-way valves, reducing cost and saving space.

4-Seat Design

3-way and 4-way Series 77 valves utilize four seats to securely support the ball, and to provide positive shutoff at any closed port.

Multiple End Connections

Series 77 valves are available in many end connections, including threaded, socket weld, flanged, butt-weld, Tri-Clamp, and others. End caps are interchangeable, permitting different end types for each piping connection.

Body & Ball Port Configurations

Many choices of body and ball porting configurations are available to suit piping system requirements.

Full Port Design

All sizes from 1/2" through 6" are full port designs at all connections. Size 8" valves are regular port designs.

Double Stem Seal; Stem Design

All Series 77 valves are supplied with a live-loaded, double stem seal configuration for reliable sealing while maintaining low operation torque. Stems are blow-out proof designs, incorporating anti-static grounding from ball to stem and stem to body.

Lockable handles

Series 77 valves in sizes 1/2" through 1-1/2" are fitted with latching/locking handles. Sizes 2" through 8" are fitted with lockable handles.

Trunnion-supported Ball

Sizes 2" and larger valves incorporate a trunnion-supported ball for positive centering and reduced seat wear.

Weld-in-place Design

Valves supplied with socket or butt-weld end connections are designed to permit welding to piping without the removal of the end caps, avoiding re-assembly alignment problems, and reducing costs by saving installation time.

ISO 5211 Mounting Pad

All valves are supplied with a mounting pad configured to ISO 5211 dimensional standards to simplify actuation.

SERIES 77 VALVE PARTS AND IDENTIFICATION

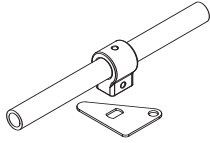

1-1/2" HANDLE

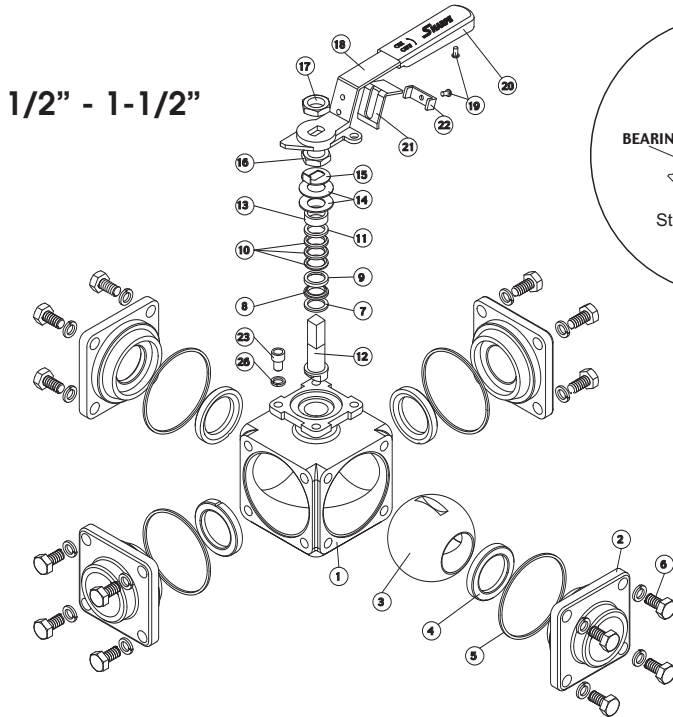

1/2" - 1-1/2"

APPLICABLE STANDARDS	
SW & Threaded Ends	ASME B16.11
Butt-weld Ends	ASME B16.25
Flange Dimensions	ASME B16.5
Testing (Options)	ASME B16.34 API 598 (Optional)

2" - 8"

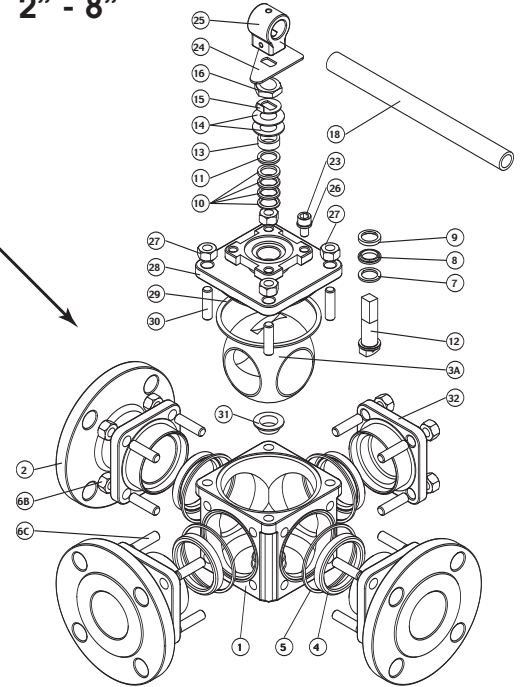

PART NO.	PART	QTY.	MATERIAL
1	Body	1	316 Stainless Steel ASTM A351 CF8M 316L Stainless Steel ASTM A351 CF3M Alloy 20 ASTM A351 CN7M Carbon Steel ASTM A216 WCB Hastelloy C ASTM A494 TYPE CW-12MW Monel ASTM A494 GR M35-1
2	Ends	3 or 4	316 Stainless Steel ASTM A351 CF8M 316L Stainless Steel ASTM A351 CF3M Alloy 20 ASTM A351 CN7M Carbon Steel ASTM A216 WCB Hastelloy C ASTM A494 TYPE CW-12MW Monel ASTM A494 GR M35-1
3 3A	Ball 1/2" - 1-1/2" Trunnion Ball 2" - 8"	1	316 Stainless Steel ASTM A351 CF8M 316L Stainless Steel ASTM A351 CF3M Alloy 20 ASTM A351 CN7M Hastelloy C ASTM A494 TYPE CW-12MW Monel ASTM A494 GR M35-1
4	Seat	4	TFM1600 / Reinforced TFE
5	Body Seal	4	PTFE
6	Bolts	16	Stainless Steel
6B	Nuts	20	Stainless Steel
6C	Stud	20	Stainless Steel
7	Lower Thrust Washer	1	TFM1600
8	Compression Ring	1	316 Stainless Steel
9	Upper Thrust Washer	1	TFM1600
10	V-Ring Stem Packing	1 set	PTFE
11	Thrust Washer	1	TFM1600
12	Stem	1	316 Stainless Steel Alloy 20 Hastelloy C 17-4 PH (Optional) Monel

PART NO.	PART	QTY.	MATERIAL
13	Gland Packing	1	304 Stainless Steel
14	Belleville Washer	2	301Stainless Steel
15	Lock Tag	1	304 Stainless Steel
16	Stem Nut	1	Stainless Steel
17	Bolt Nut	1	Stainless Steel
18	Handle	1	304 Stainless Steel
19	Rivet	1	304 Stainless Steel
20	Handle Sleeve	1	Vinyl
21	Locking Device	1	304 Stainless Steel
22	Fix Plate	1	304 Stainless Steel
23	Stop Bolt	1	Stainless Steel
24	Triangle Stopper	1	304 Stainless Steel
25	Handle Adapter	1	304 Stainless Steel
26	Spring Washer	1	304 Stainless Steel
27	Nut	4	Stainless Steel
28	Cover	1	316 Stainless Steel ASTM A351 CF8M 316L Stainless Steel ASTM A351 CF3M Alloy 20 ASTM A351 CN7M Carbon Steel ASTM A216 WCB Hastelloy C ASTM A494 TYPE CW-12MW Monel ASTM A494 GR M35-1
29	Cover Seal	1	PTFE
30	Stud	1	Stainless Steel
31	Ball Support Bearing	1	TFM1600
32	Blind End	1	316 Stainless Steel ASTM A351 CF8M 316L Stainless Steel ASTM A351 CF3M Alloy 20 ASTM A351 CN7M Carbon Steel ASTM A216 WCB Hastelloy C ASTM A494 TYPE CW-12MW Monel ASTM A494 GR M35-1

SERIES 77 DIMENSIONS

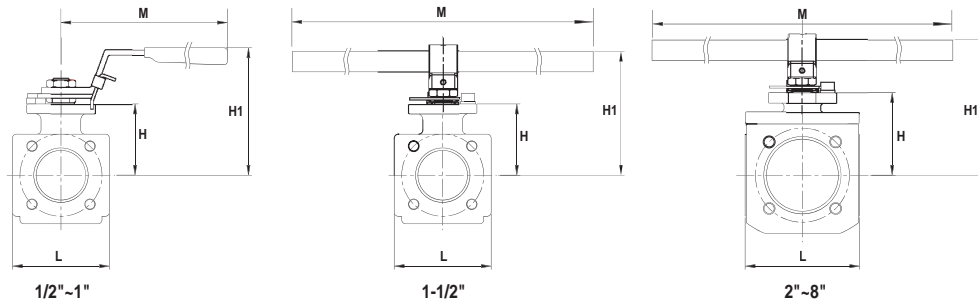

VALVE SIZE	H	H1	L	M
1/2"	1.661	3.228	2.480	4.50
3/4"	2.047	3.386	2.736	5.10
1"	2.177	3.858	3.150	5.10
1-1/2"	2.972	5.000	4.094	7.90
2"	3.150	5.374	4.291	15.75
2-1/2"	3.819	6.378	5.000	19.70
3"	4.252	7.323	6.035	19.70
4"	5.079	8.386	7.362	25.60
6"	8.465	11.024	11.260	31.50
8"	8.465	11.024	11.260	31.50

THREADED. BUTT WELD.
SOCKET WELD END

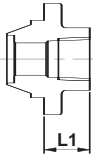

L1

VALVE SIZE	L1
1/2"	0.862
3/4"	0.807
1"	0.917
1-1/2"	0.980
2"	1.220
4"	2.008

T-CLAMP
END

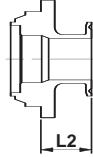

L2

VALVE SIZE	L2
1/2"	1.455
3/4"	1.430
1"	1.524
1-1/2"	1.324
2"	1.505
2-1/2"	1.765
3"	1.746
4"	2.041

150# FLANGE
END

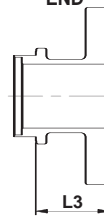

L3

VALVE SIZE	L3
1/2"	1.677
3/4"	1.661
1"	1.661
1-1/2"	2.134
2"	2.185
2-1/2"	3.012
3"	2.591
4"	3.150
6"	3.819
8"	3.814

300# FLANGE
END

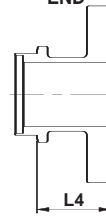

L4

VALVE SIZE	L4
1/2"	1.787
3/4"	1.852
1"	1.988
1-1/2"	2.350
2"	2.185
2-1/2"	3.012
3"	2.591
4"	3.150

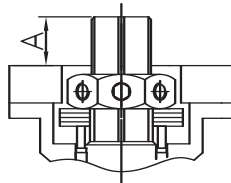
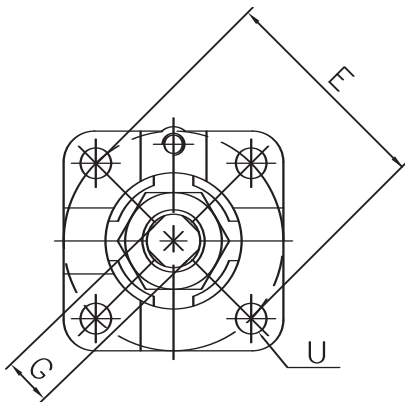

SIZE	E	G	A	U
1/2"	1.65	0.35	0.35	0.24
3/4"	1.96	0.43	0.43	0.28
1"	1.96	0.43	0.43	0.28
1-1/2"	2.76	0.55	0.59	0.35
2"	2.76	0.55	0.60	0.35
2-1/2"	4.01	0.67	1.05	0.47
3"	4.01	0.67	1.05	0.47
4"	4.01	0.87	1.20	0.47

**SERIES 77
DIMENSIONS**

THREADED ~ SOCKETWELD ~ BUTT-WELD

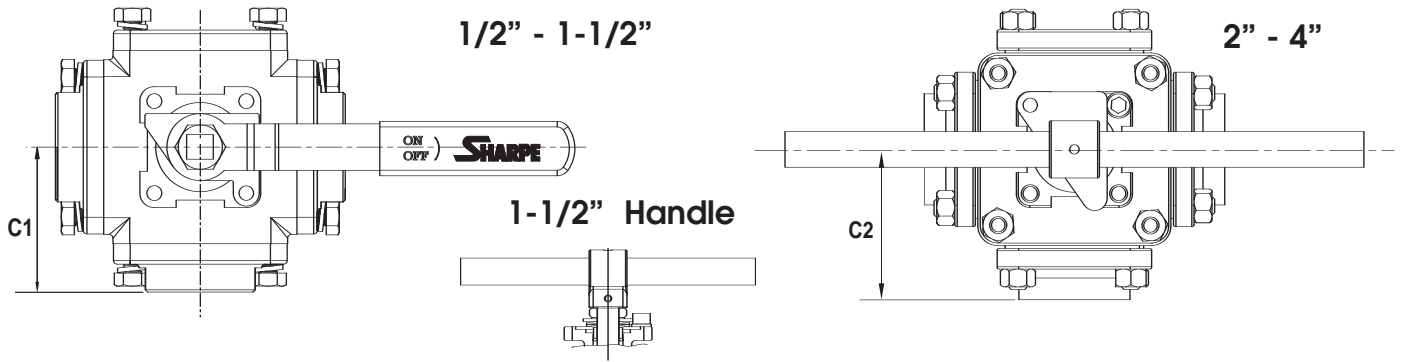

TRI-CLAMP

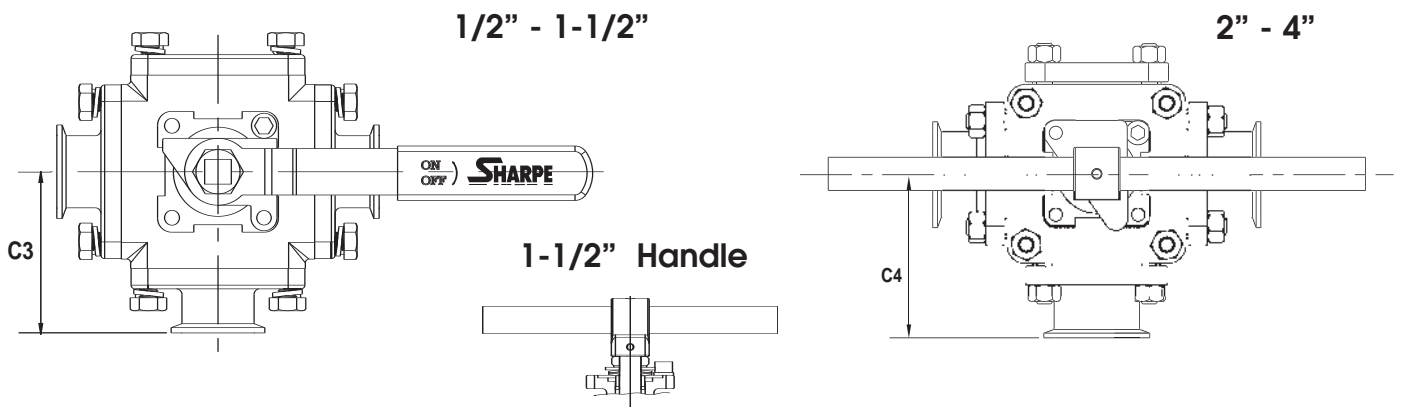

150# & 300#

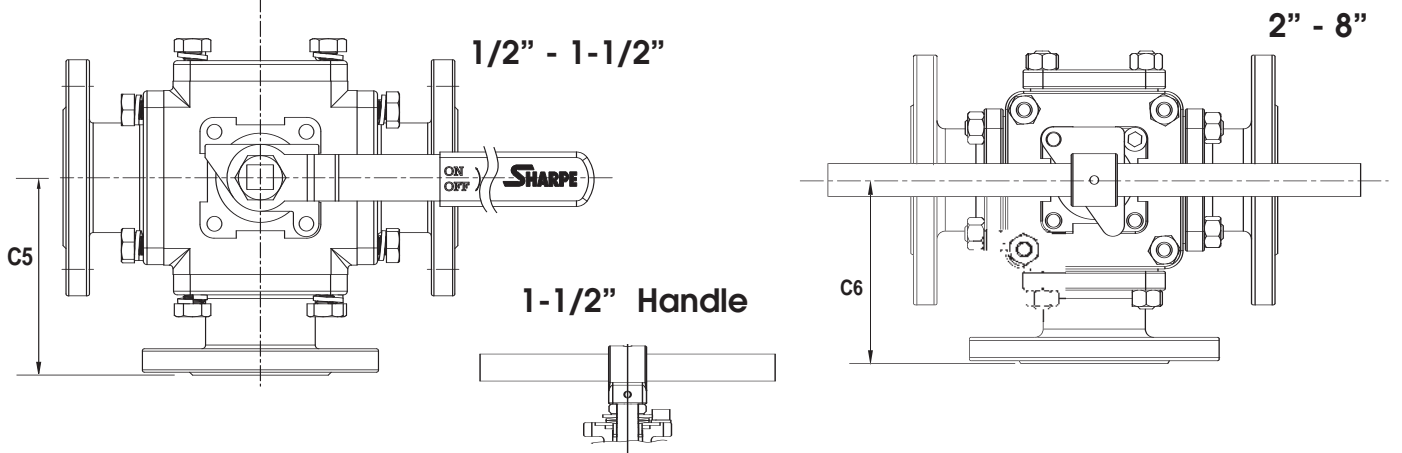

SIZES	C1	C2	C3	C4	150#		300#	
					C5	C6	C5	C6
1/2"	2.10		2.70		2.90		3.10	
3/4"	2.20		2.80		3.10		3.20	
1"	2.50		3.10		3.40		3.60	
1-1/2"	3.00		3.40		4.20		4.40	
2"		3.40		3.90		4.40		4.40
2-1/2"		5.50		4.70		5.50		5.50
3"		5.70		4.95		5.60		5.60
4"		6.70		5.90		6.90		6.85
6"						9.50		
8"						9.50		

FLOW PLAN CHART

T-PORT 90° TURN

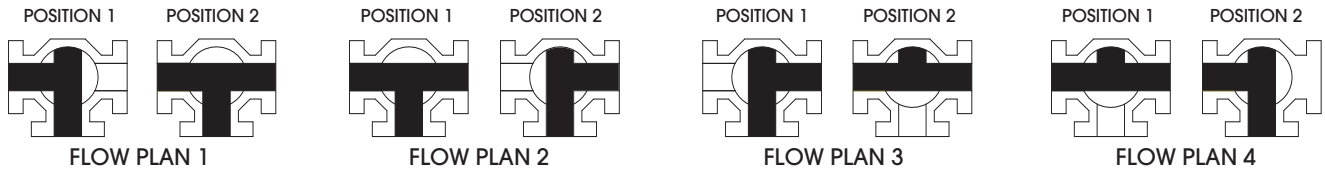

T-PORT 180° TURN

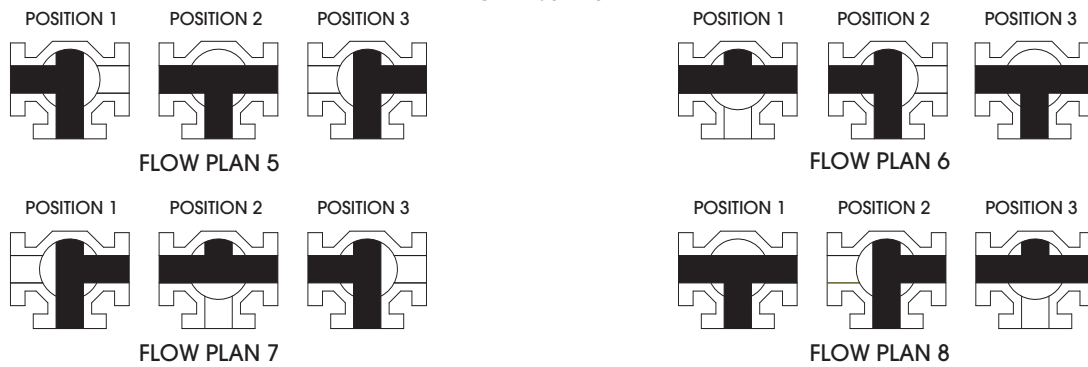

L - PORT 90° TURN

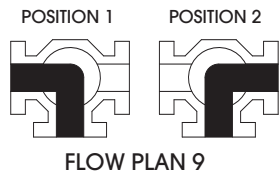

L - PORT 180° TURN

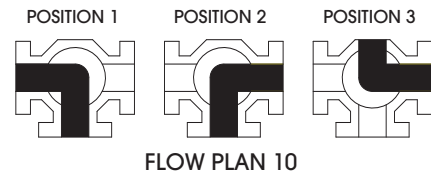

LL - PORT 90° TURN

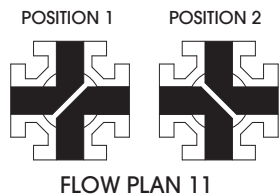

L - PORT 180° TURN

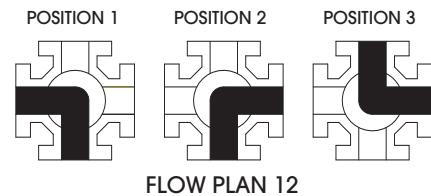

T-PORT 270° TURN

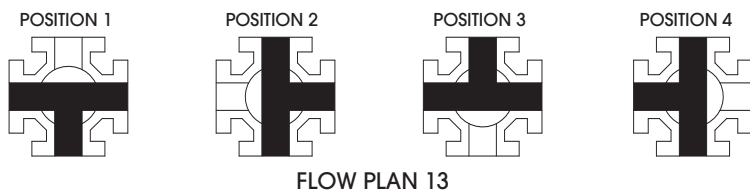

4 - WAY 90° TURN

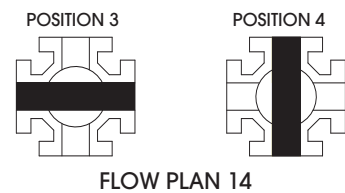

CV DATA

VALVE SIZE	T PORT	L PORT	LL PORT
1/2"	16	10	8
3/4"	24	14	12
1"	45	25	22
1-1/2"	100	56	46
2"	430	110	95
2-1/2"	670	160	137
3"	1170	260	220
4"	2070	430	366
6"	5000	980	830
8"***	5000	980	830

* U.S. Gallon per minute.
 ** Standard Port

TORQUE DATA

VALVE SIZE	IN / LBS.
1/2"	100
3/4"	180
1"	200
1-1/2"	500
2"	650
2-1/2"	1050
3"	1320
4"	2880
6"	3800
8"***	3800

SEAT PRESSURE/TEMPERATURE RATING CHART

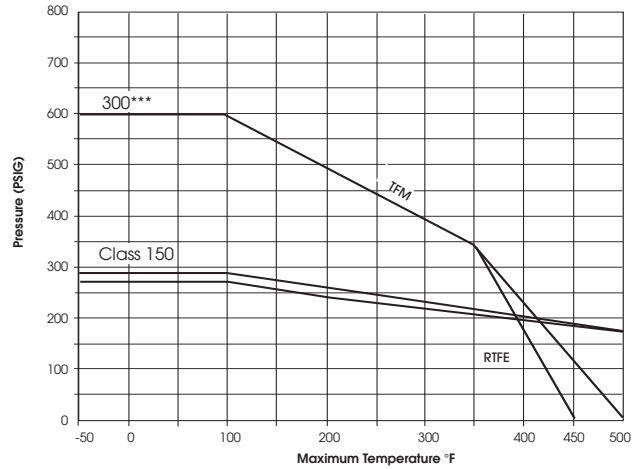

*** Class 300 flanged valves limited to maximum seat ratings.

SERIES 77 3-WAY BALL VALVE PARTS WEIGHT LIST

VALVE SIZE	BODY	THREADED SOCKET WELD BUTT-WELD END	FLANGED END		TRI-CLAMP END	BLIND END
			150 LB.	300 LB.		
1/2"	2.00	0.6	1.60	2.00	0.80	0.50
3/4"	2.50	0.8	2.00	3.20	0.95	0.50
1"	3.10	1.3	2.70	4.25	1.60	0.95
1-1/2"	5.50	1.8	5.00	8.22	2.20	1.65
2"	5.50	2.7	6.00	8.20	2.90	1.90
2-1/2"	8.20		10.00	12.90	3.90	3.00
3"	11.50		11.00	16.60	4.20	3.20
4"	21.50		21.90	30.00	9.70	8.30
6"	60.00		51.00			33.00
8"	60.00		84.00			33.00

SHARPE® VALVES

Choose from our full line of high quality valves and actuators to meet your needs.

Whatever your flow control requirements are, Sharpe® has the right products and service to meet your needs today.

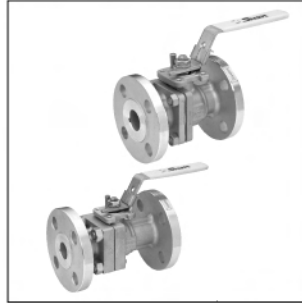

HOW TO ORDER

SIZE	SERIES	BODY	BALL & STEM	SEAT	SEAL	ENDS	END CAP TYPE **	FLOW PLAN	OPTIONS
1/2"	77	6 = 316 Stainless Steel	6 = 316 Stainless Steel	M = TFM Seat	T = Teflon	6 = 316 Stainless Steel	A = Threaded Ends (NPT)	1	EP = Electro Polish
3/4"		4 = Carbon Steel	2 = Alloy 20	C = TFM Cavity Fill	G = Grafoil	4 = Carbon Steel	B = Socket Weld	2	GO = Gear Operator
1"		2 = Alloy 20	5 = Hastelloy C	R = Reinforced TFEI		2 = Alloy 20	C = Butt Weld Sch. 10, 40, & 80	3	OH = Oval Handle
1-1/2"		5 = Hastelloy C	6L = 316L Stainless Steel			5 = Hastelloy C	D = 150#RF Flange	4	X = Oxygen Service
2"			6L = 316L Stainless Steel			6L = 316L Stainless Steel	E = 300#RF Flange***	5	7 = 17 - 4 PH Stem
2-1/2"							TUBE ENDS	6	A = Nace
3"							F = Tri-Clamp Ends 180 Grit	7	
4"							G = Tri-Clamp Ends 240 Grit	8	
6"							H = Tri-Clamp Ends 320 Grit	9	
8**							K = Extended Butt Weld 180 Grit	10	
						M = Extended Butt Weld 240 Grit	11		
						N = Extended Butt Weld 320 Grit	12		
						R = Short Butt Weld 180 Grit	13		
						S = Short Butt Weld 240 Grit	14		
						V = Short Butt Weld 320 Grit			

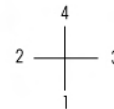

1" 77 6 6 M T 6 D 3 EP

* Standard port

** When multiple end cap configurations are required. Specify the end cap types and connection locations, for example, 1-A, 2-B, 3-C.

*** Class 300 flanged valves limited to maximum seat ratings.

SHARPE® VALVES

A Division of Smith-Cooper International, LLC

Toll Free: 1-877-7SHARPE

(877) 774-2773

Fax: (708) 562-9250

Email: info@sharpevalves.com

www.sharpevalves.com

1260 Garnet Drive

Northlake, Illinois 60164 U.S.A.