

SHARPE[®] VALVES



SERIES C
CRYOGENIC BALL VALVES

SHARPE® HIGH PERFORMANCE CRYOGENIC BALL VALVES

Sharpe® Cryogenic Series Ball Valves offer as standard features advantages that other valve manufacturers offer only as costly extras. This is the Sharpe® advantage.

STANDARD FEATURES

Valves meet test specifications of BS6364 for Cryogenic Valves

Pressure relief hole in side of ball

Permanent Attached Flow Arrow

Relief hole in stem slot

Live load stem packing (Belleville)

Visual position indicator

Special cleaning

Packing

Extended stem and bonnet

Size Ranges and Pressure Classes Available

Series C84/C99/CD84

Bottom Entry Stem

High Cycle Stem Packing

Fully Encapsulated Body Seals
(Series C84/C99/CD84)

Integral Mounting Pad
ISO 5211

Lockable Handle

Traceability

ADVANTAGES

Insures proper construction and testing.

Upstream vent for excessive valve cavity pressure in closed position.

Reduce possibility of incorrect valve installation.

Equalizes valve cavity pressure and line pressure in open position.

Provides long intervals between stem packing adjustments, decreasing emissions through the packing.

Provides easy identification of valve position

Ready to use in critical applications

Keeps the valve in Factory-new condition until it is to be installed.

Positions stem and stem packing away from cryogenic fluid to prevent stem seal freeze-up and to ensure emission-free service.

1/2" - 2-1/2" Standard Port, 1/2" - 2" Full Port, Meet wall thickness requirement of ANSI B 16.34 for class 600, 3" - 4" Standard Port Class 300, and 2-1/2" - 3" Full Port Class 300.

In-line serviceable swing-out center section allows easy access to internal valve components without disturbing alignment of pipe.

Prevents accidental removal of stem under pressure. Self adjusts with pressure and temperature fluctuations. Bottom entry system helps prevent accidents and injuries.

PEEK and Nova* thrust bearings and stem seals extend valve cycle life and are the best choice for actuation.

Allows valve ends to be welded in line without disassembly, saving costly labor time. Also prevents seal ruptures in high pressure and eliminates cold flow.

Ideal for actuation. Centering lip feature assures precise alignment of bracket, stem and coupler. Allows for secondary containment unit to be added when necessary.

All Sharpe® Series C Valves meet OSHA standards with locking device. Keeps valves from being opened or closed accidentally.

Heat numbers are provided on all valve bodies and ends. CMTR's (certified mill test reports) are available upon request.

* Carbon and Graphite Filled TFE

SERIES C84/C99 VALVE PARTS AND IDENTIFICATION

C84 1/2" - 2-1/2"
C99 1/2" - 2"

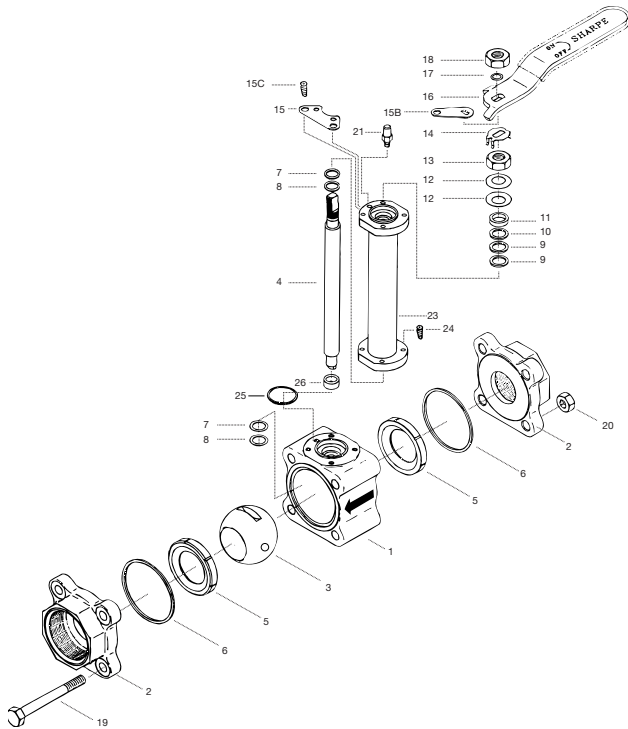

C84 3" - 4"
C99 2-1/2" - 3"

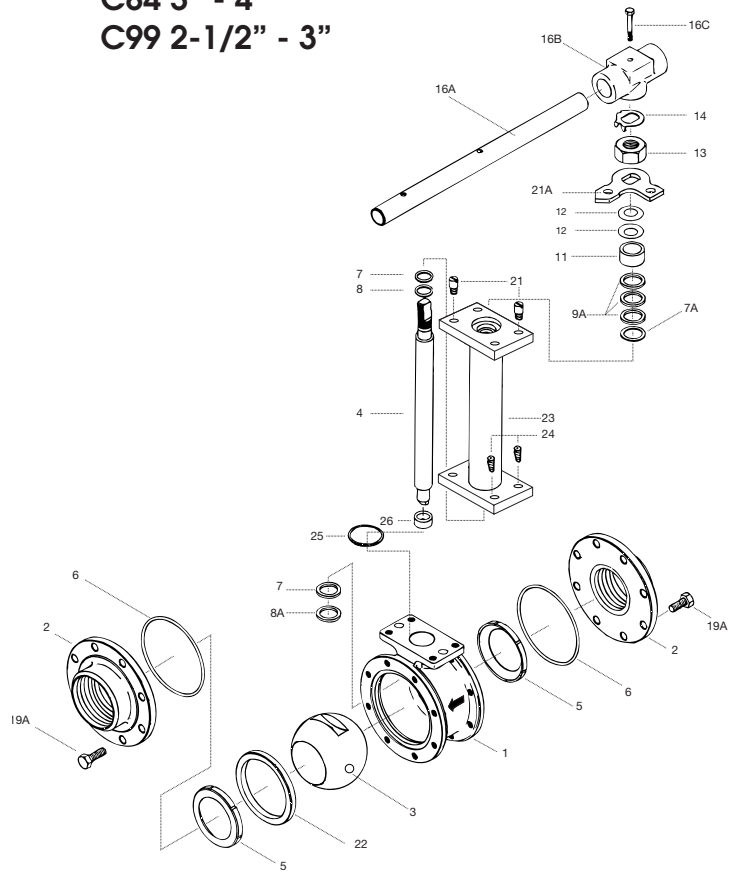

PART NO.	PART	QTY.	MATERIAL
1	Body	1	Stainless Steel 316 ASTM A351 CF8M
2	Pipe Ends	2	Stainless Steel 316L Bronze ASTM A351 CF3M ASTM B62/B584 C83600
3	Ball	1	Stainless Steel 316
4	Stem	1	Stainless Steel 316 / 17-4PH
5	Valve Seat	2	PCTFE - KEL-F®** / Reinforced TFE
6	Body Seal	2	TFM / RTFE
7	Thrust Bearing	1	Nova*
7A	Stem Location Ring (3" & 4")	1	Stainless Steel
8	Thrust Bearing	1	PEEK
8A	Thrust Bearing	1	Nova*
9	Stem Packing	2	Nova*
9A	Stem Packing (3" & 4")	3	Nova*
10	Seal Protector	1	PEEK
11	Gland Packing	1	Stainless Steel
12	Belleville Washer	2	Stainless Steel
13	Packing Nut	1	Stainless Steel
14	Lock Tab	1	Stainless Steel
15	Lower Lock Latch	1	Stainless Steel

PART NO.	PART	QTY.	MATERIAL
15B	Upper Lock Latch	1	Stainless Steel
15C	Latch Bolt	1	Stainless Steel
16	Handle (1/4"-2")	1	Stainless Steel
16A	Wrench (3" & 4")	1	Cad Plate Carbon Steel
16B	Wrench Block	1	Stainless Steel
16C	Hex Head Bolt	1	Stainless Steel
17	Lock Washer	1	Stainless Steel
18	Handle Nut (1/4"-2")	1	Stainless Steel
19	Body Bolts	4	Stainless Steel
19A	Body Connector Bolts	16	Stainless Steel
20	Nuts	4	Stainless Steel
21	Stop Pin (1/4"-1/2")	1 2	Stainless Steel Stainless Steel
21A	Stopper	1	Stainless Steel
22	Seat Retainer	1	Stainless Steel
23	Cryo Extension	1	Stainless Steel 316
24	Cryo Extension Bolts	4	Stainless Steel 304
25	Bonnet Seal	1	TFM / TFE
26	Cryo Extension Bushing	1	TFM

* Nova: Carbon and Graphite Filled TFE

** Kel-F® is registered trade mark of 3M Company.

*** TFM is registered trade mark of Dyneon,LLC

SERIES CD84

VALVE PARTS AND IDENTIFICATION

1/2" - 2-1/2"

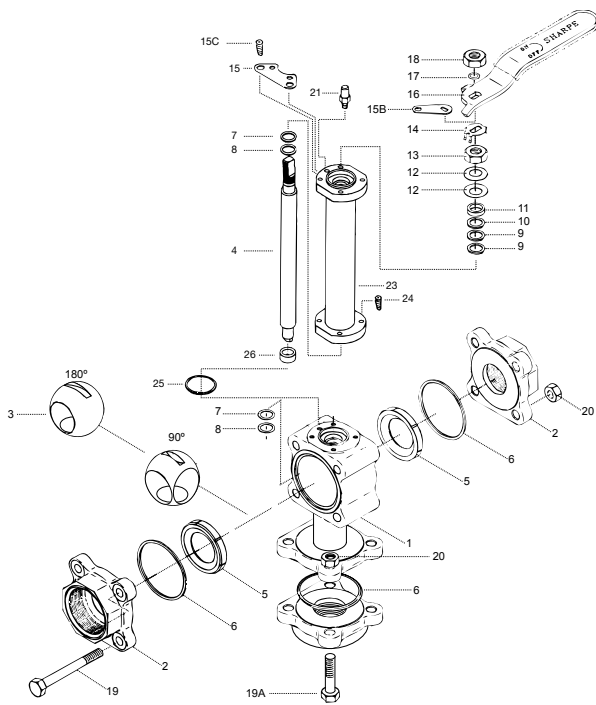

3" - 4"

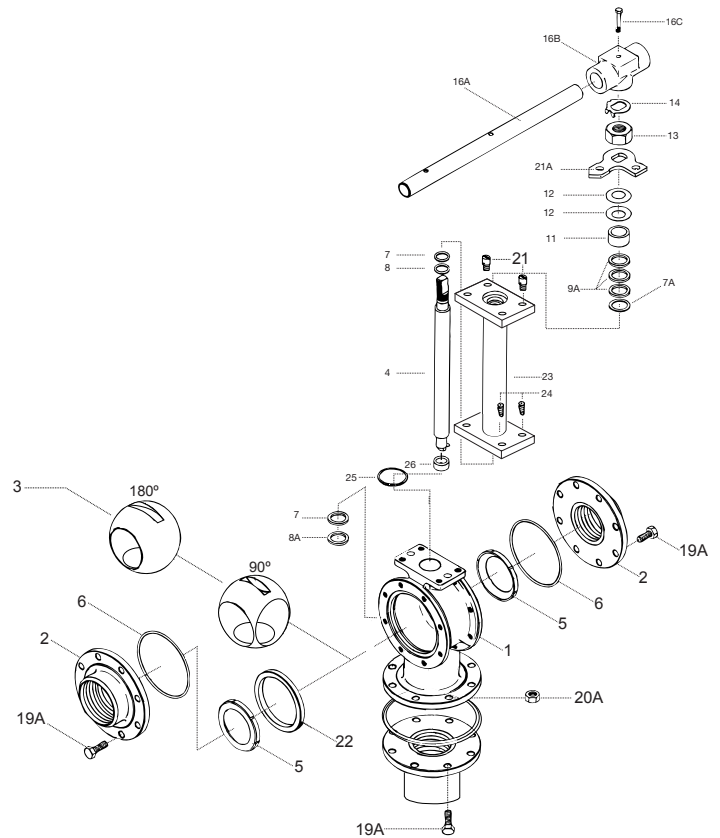

PART NO.	PART	QTY.	MATERIAL
1	Body	1	Stainless Steel 316 ASTM A351 CF8M
2	Pipe Ends	3	Stainless Steel 316L ASTM A351 CF3M Bronze ASTM B62/B584 C83600
3	Ball	1	Stainless Steel 316
4	Stem	1	Stainless Steel 316 / 17-4PH
5	Valve Seat	2	PCTFE - KEL-F® / Reinforced TFE
6	Body Seal	3	TFM / TFE
7	Thrust Bearing	1	Nova*
7A	Stem Location Ring (3" & 4")	1	Stainless Steel
8	Thrust Bearing	1	PEEK
8A	Thrust Bearing	1	Nova*
9	Stem Packing	2	Nova*
9A	Stem Packing (3" & 4")	3	Nova*
10	Seal Protector	1	PEEK
11	Gland Packing	1	Stainless Steel
12	Belleville Washer	2	Stainless Steel
13	Packing Nut	1	Stainless Steel
14	Lock Tab	1	Stainless Steel
15	Lower Lock Latch	1	Stainless Steel
15B	Upper Lock Latch	1	Stainless Steel
15C	Latch Bolt	1	Stainless Steel

PART NO.	PART	QTY.	MATERIAL
16	Handle (1/4"-2")	1	Stainless Steel
16A	Wrench (3" & 4")	1	Cad Plate Carbon Steel
16B	Wrench Block	1	Stainless Steel
16C	Hex Head Bolt	1	Stainless Steel
17	Lock Washer	1	Stainless Steel
18	Handle Nut (1/4"-2")	1	Stainless Steel
19	Body Bolts	4	Stainless Steel
19A	Body Connector Bolts	4/24	Stainless Steel
20	Nuts	8	Stainless Steel
20A	Nuts	16	Stainless Steel
21	Stop Pin (1/4"-1/2")	1	Stainless Steel
		2	Stainless Steel
21A	Stopper	1	Stainless Steel
22	Seat Retainer	1	Stainless Steel
23	Cryo Extension	1	Stainless Steel 316
24	Cryo Extension Bolts	4	Stainless Steel 304
25	Bonnet Seal	1	TFM / TFE
26	Cryo Extension Bushing	1	TFM

SERIES C50

VALVE PARTS AND IDENTIFICATION

CLASS 150 BLOW OUT PROOF STEM LOCKING DEVICE

1/2" - 2"

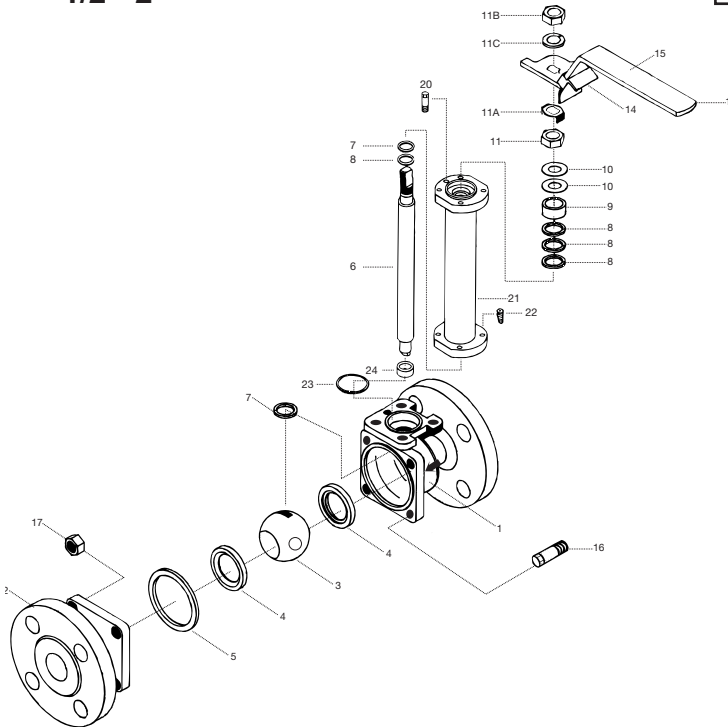

2-1/2" - 4"

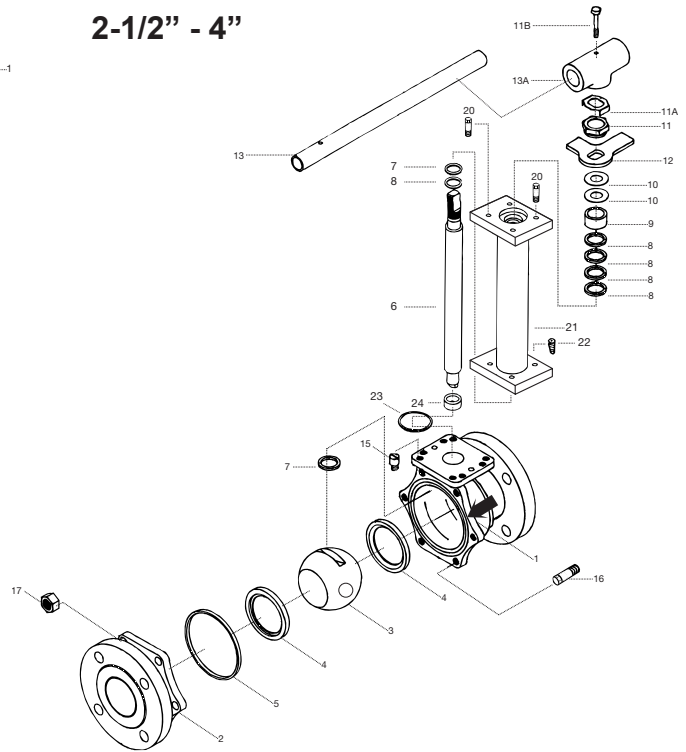

APPLICABLE STANDARDS	
Shell Wall Thickness	ASME B 16.34
Face to Face Dimensions	ASME B 16.10
Flange Dimensions	ASME B 16.5
Tests	ASME B 16.34 API 598
Basic Design	API 608

PART NO.	PART	QTY.	MATERIAL
1	Body	1	Stainless Steel 316 ASTM A351 CF8M
2	End Connector	1	Stainless Steel 316 ASTM A351 CF8M
3	Ball	1	Stainless Steel 316
4	Seat	2	PCTFE - KEL-F® / Reinforced TFE
5	Body Seal	1	TFE
6	Stem	1	Stainless Steel 316 / 17-4PH
7	Thrust Bearing	2	Reinforced TFE
8	Stem Packing	3/4	Reinforced TFE
9	Gland Packing	1	304 Stainless Steel
10	Belleville Washer	2	304 Stainless Steel
11	Packing Nut	1	304 Stainless Steel
11A	Lock Tab	1	Stainless Steel
11B	Handle Nut	1	304 Stainless Steel
11C	Lock Washer	1	304 Stainless Steel (1/2"-2")
12	Stopper	1	304 Stainless Steel

PART NO.	PART	QTY.	MATERIAL
13	Handle	1	304 Stainless Steel (1/2"-2") Galvanized Steel (2-1/2"-4")
13A	Wrench Block	1	Stainless Steel
13B	Hex Head Bolt	1	304 Stainless Steel
14	Locking Device (1/2"-2")	1	304 Stainless Steel
15	Sleeve	1	Vinyl
16	Body Stud	SEE* N	A193 B8M
17	Nut	SEE* N	A194 B8M
20	Stop Pin (1/2"-2") (2-1/2"-4")	1 2	304 Stainless Steel 304 Stainless Steel
21	Cryo Extension	1	Stainless Steel 316
22	Cryo Extension Bolts	4	Stainless Steel
23	Bonnet Seal	1	TFM / TFE
24	Cryo Extension Bushing	1	TFM

*See Dimensions

SERIES C84 DIMENSIONS

1/2" - 2"

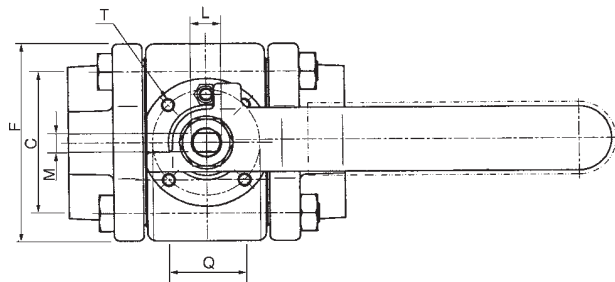

2-1/2"

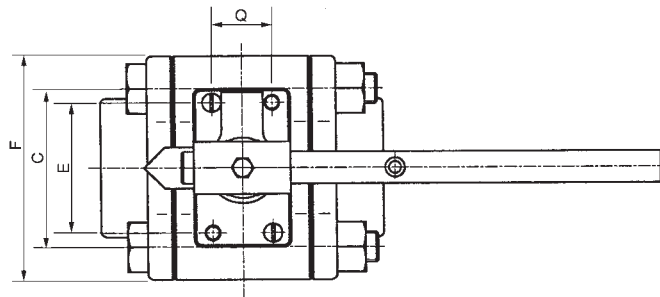

SIZE	A			B	C	D	E	F	G	L	M	N	Q	R	T	V	FLOW COEFF. Cv	APPROX. WEIGHT	PORT SIZE
	THRD. SW / BW	150#	300#																
1/2"	2.78	4.25	5.50	.969	1.50	6.25	1.00	2.05	6.59	3/8"-24 UNF	.22	6.87	1.00	4.50	M5	.28	8	3.90	.44
3/4"	2.78	4.62	6.00	.969	1.50	6.25	1.00	2.05	6.59	3/8"-24 UNF	.22	6.87	1.00	4.50	M5	.28	12	3.90	.56
1"	3.68	5.00	6.50	1.25	1.75	7.50	1.18	2.42	8.19	7/16"-20 UNF	.30	8.40	1.18	5.75	M5	.30	32	6.70	.81
1-1/4"	4.22	5.50	7.00	1.63	2.00	7.65	1.18	2.70	8.38	7/16"-20 UNF	.30	8.70	1.18	5.75	M5	.30	46	7.60	1.00
1-1/2"	4.55	6.50	7.50	1.91	2.25	9.70	1.38	3.16	10.88	9/16"-18 UNF	.35	11.16	1.38	7.00	M6	.42	80	12.00	1.25
2"	5.00	7.00	8.50	2.22	2.62	9.90	1.38	3.56	11.06	9/16"-18 UNF	.35	11.35	1.38	7.00	M6	.42	120	14.00	1.50
2-1/2"	5.86	7.50	9.50	2.86	3.35	10.90	2.75	4.57	16.56	M20	.55	17.58	1.25	10.00	M8	.55	240	41.00	2.00

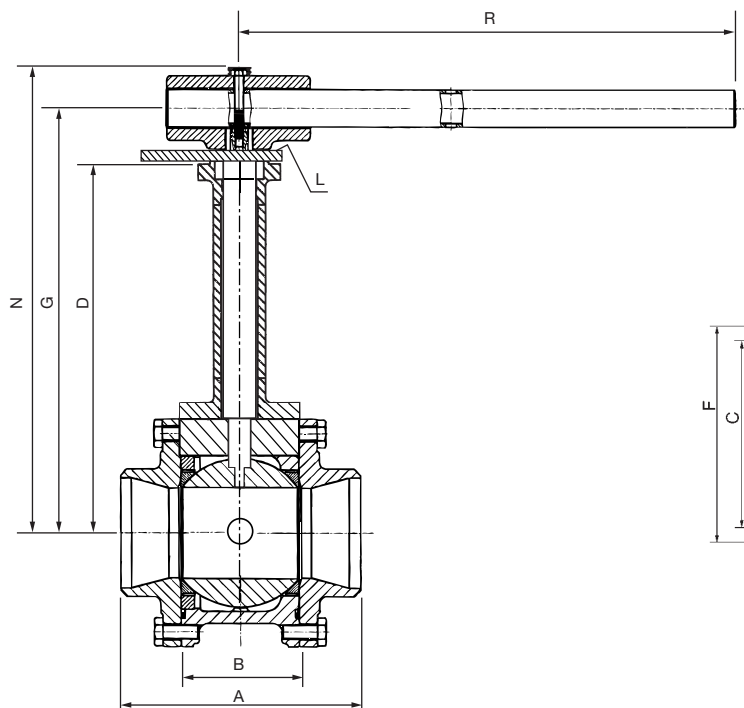

3" - 4"

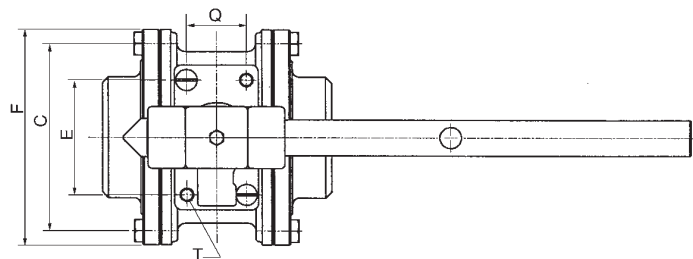

SIZE	A			B	C	D	E	F	G	L	M	N	Q	R	T	V	FLOW COEFF. Cv	APPROX. WEIGHT	PORT SIZE
	THRD. SW / BW	150#	300#																
3"	6.66	8.00	11.12	3.28	5.50	16.09	3.38	6.44	19.44	1-14 UNS	.745	19.69	1.75	13.80	M10	.66	350	50.00	2.50
4"	8.40	9.00	12.00	4.28	6.97	16.65	3.38	8.12	20.00	1-14 UNS	.745	20.24	1.75	22.00	M10	.66	720	71.00	3.25

SERIES C99 DIMENSIONS

1/2" - 1-1/2"

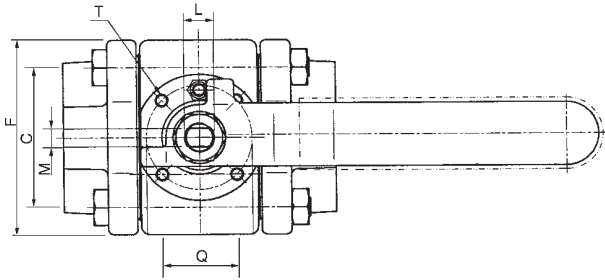

2"

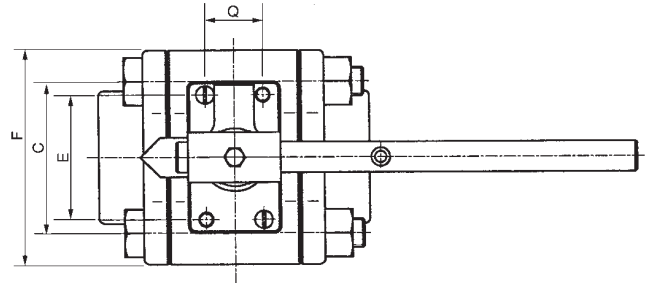

SIZE	A			B	C	D	E	F	G	L	M	N	Q	R	T	V	FLOW COEFF. Cv	APPROX. WEIGHT	PORT SIZE
	THRD. SW / BW	150#	300#																
1/2"	2.78	4.25	5.50	.969	1.50	6.25	1.00	2.05	6.59	3/8"-24 UNF	.22	6.87	1.00	4.50	M5	.28	38	3.90	.56
3/4"	3.68	4.62	6.00	1.25	1.75	7.50	1.18	2.42	8.19	7/16"-20 UNF	.30	8.40	1.18	5.75	M5	.30	71	6.70	.81
1"	4.22	5.00	6.50	1.63	2.00	7.65	1.18	2.70	8.38	7/16"-20 UNF	.30	8.70	1.18	5.75	M5	.30	110	7.60	1.00
1-1/4"	4.55	5.50	7.00	1.91	2.25	9.70	1.38	3.16	10.88	9/16"-18 UNF	.35	11.16	1.38	7.00	M6	.42	230	12.00	1.25
1-1/2"	5.00	6.50	7.50	2.22	2.62	9.90	1.38	3.56	11.06	9/16"-18 UNF	.35	11.35	1.38	7.00	M6	.42	350	14.00	1.50
2"	5.86	7.00	8.50	2.86	3.35	10.90	2.75	4.57	16.56	M-20	.55	17.58	1.25	10.00	M8	.55	600	41.0	2.00

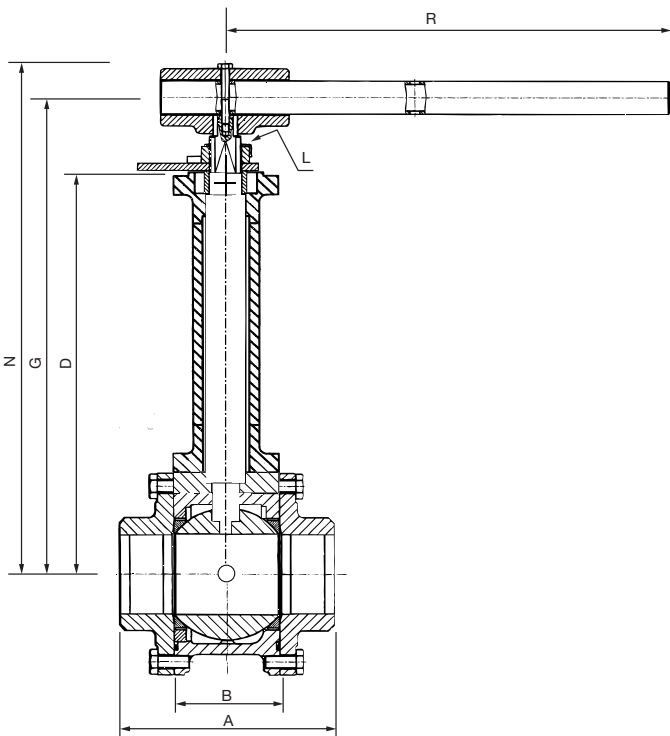

2-1/2" - 3"

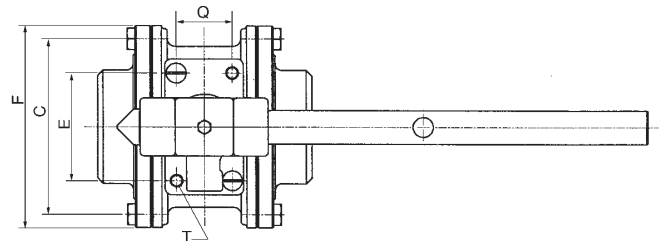

SIZE	A			B	C	D	E	F	G	L	M	N	Q	R	T	V	FLOW COEFF. Cv	APPROX. WEIGHT	PORT SIZE
	THRD. SW / BW	150#	300#																
2-1/2"	6.66	7.50	9.50	3.28	5.50	16.09	3.38	6.44	19.44	1-14 UNS	.745	19.69	1.75	13.80	M10	.66	780	50.0	2.50
3"	8.40	8.00	11.12	4.28	6.97	16.65	3.38	8.12	20.00	1-14 UNS	.745	20.24	1.75	22.00	M10	.66	1200	71.0	3.25

SERIES CD84 DIMENSIONS

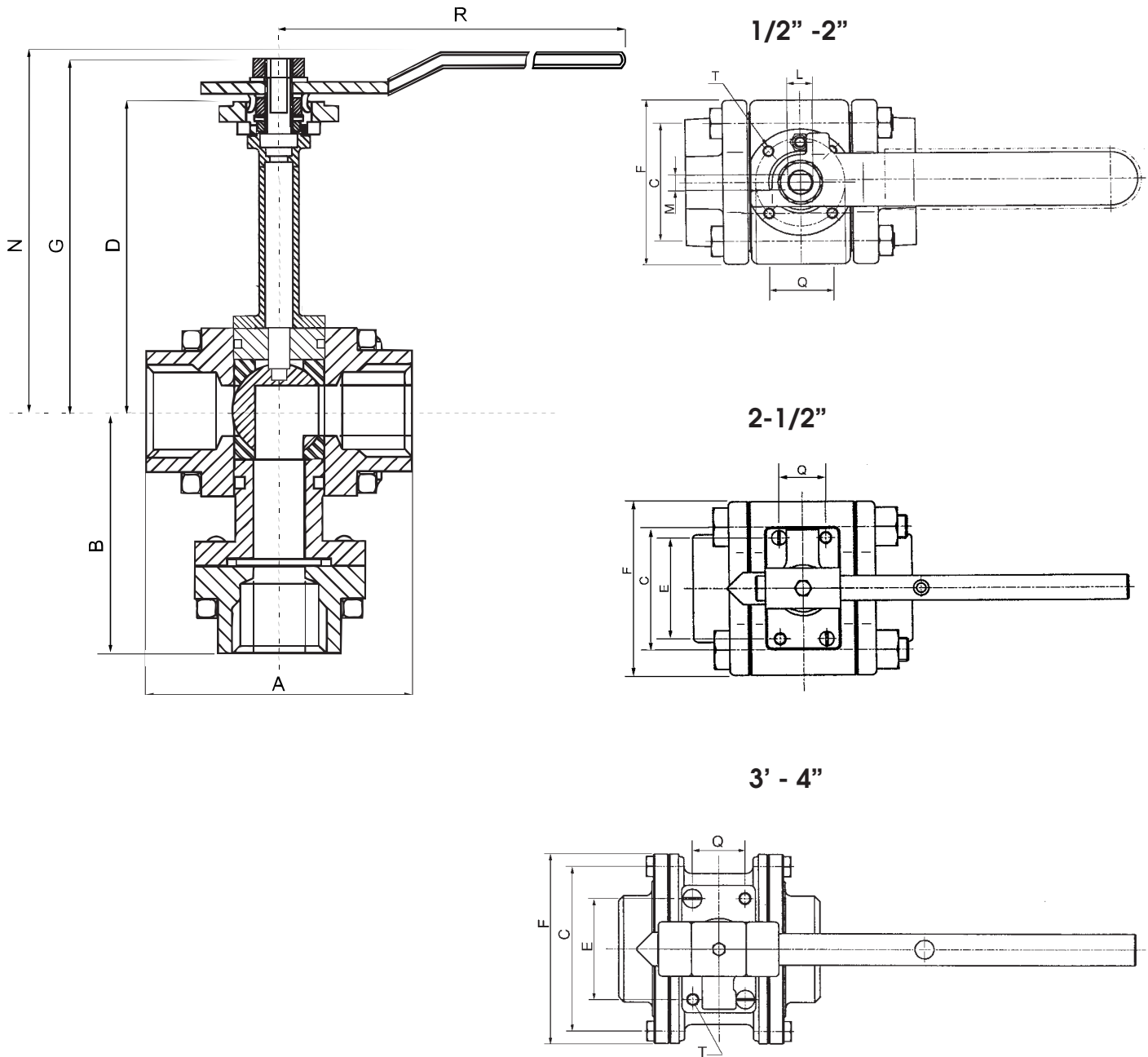

SIZE	A			B	C	D	E	F	G	L	M	N	Q	R	T	V	BOTTOM PORT	CV* US GAL. GPM
	THRD. SW / BW	150#	300#															
1/2"	2.78	4.25	5.50	2.75	1.50	6.25	1.00	2.05	6.59	3/8"-24 UNF	.22	6.87	1.00	4.50	M5	.28	0.47	5
3/4"	2.78	4.62	6.00	2.75	1.50	6.25	1.00	2.05	6.59	3/8"-24 UNF	.22	6.87	1.00	4.50	M5	.28	0.47	5
1"	3.68	5.00	6.50	3.45	1.75	7.50	1.18	2.42	8.19	7/16"-20 UNF	.30	8.40	1.18	5.75	M5	.30	0.63	13
1-1/2"	4.55	6.50	7.50	4.15	2.25	9.70	1.38	3.16	10.88	9/16"-18 UNF	.35	11.16	1.38	7.00	M6	.42	1.05	31
2"	5.00	7.00	8.50	4.50	2.62	9.90	1.38	3.56	11.06	9/16"-18 UNF	.35	11.35	1.38	7.00	M6	.42	1.40	48
2-1/2"	5.86	7.50	9.50	6.00	3.35	10.90	2.92	4.57	16.56	M20	.55	17.58	1.25	10.00	M8	.55	1.84	82
3"	6.66	8.00	11.12	7.25	5.50	15.90	3.38	6.44	19.25	1"-14 UNS	.745	19.50	1.75	13.80	M10	.66	2.00	120
4"	8.40	9.00	12.00	8.60	6.97	16.50	3.38	8.12	19.84	1"-14 UNS	.745	20.09	1.75	22.00	M10	.66	2.50	155

SERIES C50 DIMENSIONS

1/2" - 2"

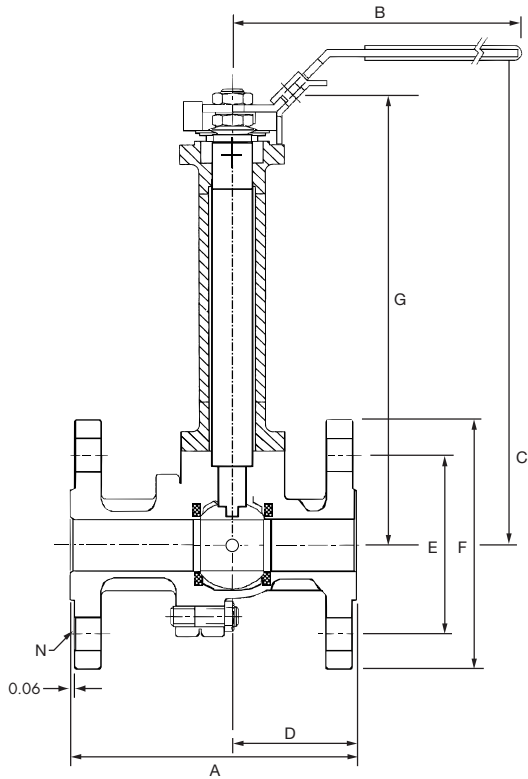

2-1/2" - 4"

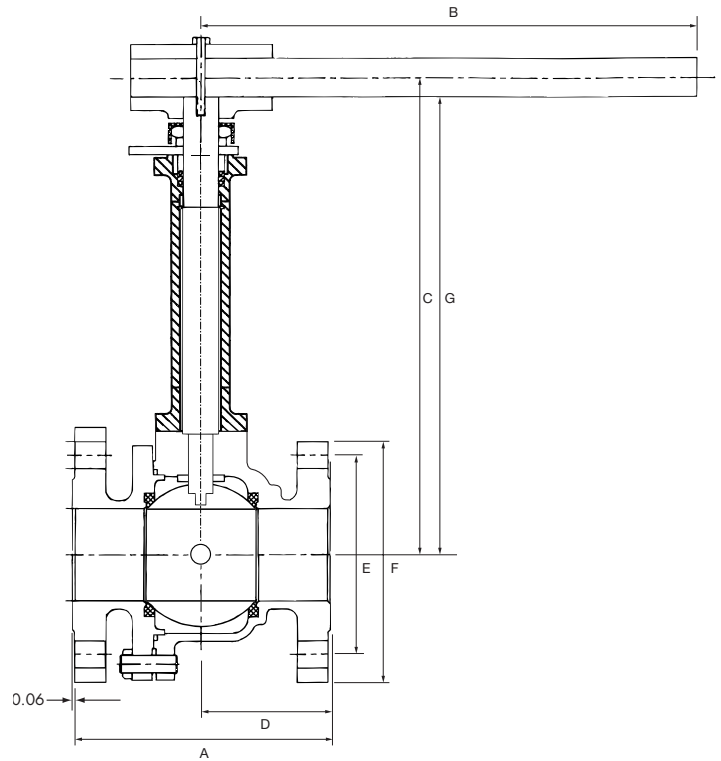

SIZE	A		B		C		D		E		F	
	150#	300#	150#	300#	150#	300#	150#	300#	150#	300#	150#	300#
1/2"	4.25	5.50	4.75	4.75	9.70	9.70	1.80	2.64	2.38	2.62	3.50	3.75
3/4"	4.62	6.00	4.75	4.75	9.90	9.90	2.00	2.94	2.75	3.25	3.85	4.60
1"	5.00	6.50	6.22	6.22	11.90	11.90	2.12	3.19	3.13	3.50	4.25	4.90
1-1/2"	6.50	7.50	9.00	9.00	12.70	12.70	2.76	3.63	3.56	4.50	5.00	6.15
2"	7.00	8.50	9.00	9.00	17.00	17.00	3.08	4.30	4.75	5.00	6.00	6.50
2-1/2"	7.50	9.50	13.75	13.75	18.70	18.70	3.09	4.90	5.50	5.86	7.00	7.48
3"	8.00	11.12	13.75	13.75	19.00	19.00	3.74	5.40	6.00	6.62	7.48	8.26
4"	9.00	12.00	13.75	13.75	19.70	19.70	4.46	5.94	7.50	7.88	9.01	10.00

SIZE	N		G		H		I		J		K		W	
	150#	300#	150#	300#	150#	300#	150#	300#	150#	300#	150#	300#	150#	300#
1/2"	4	4	9.60	9.60	3/8-24 UNF		0.22	0.22	0.28	0.28	0.63	0.63	M5	M5
3/4"	4	4	9.75	9.75	3/8-24 UNF		0.22	0.22	0.28	0.28	0.63	0.63	M5	M5
1"	4	4	11.75	11.75	7/16-20 UNF		0.30	0.30	0.30	0.30	0.90	0.90	M6	M6
1-1/2"	4	4	12.50	12.50	9/16-18 UNF		0.35	0.35	0.42	0.42	1.18	1.18	M8	M8
2"	4	8	16.80	16.80	9/16-18 UNF		0.35	0.35	0.42	0.42	1.18	1.18	M8	M8
2-1/2"	4	8	18.45	18.45	M20		0.55	0.55	0.55	0.55	1.83	1.83	M10	M10
3"	4	8	18.75	18.75	1"-14 UNS		0.745	0.745	0.66	0.66	1.83	1.83	M10	M10
4"	8	8	19.45	19.45	1"-14 UNS		0.745	0.745	0.66	0.66	1.83	1.83	M10	M10

**SERIES C50
DIMENSIONS**

1/2" - 4"

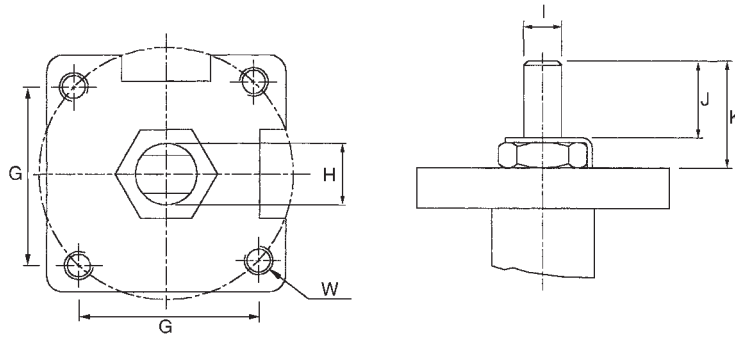

PERFORMANCE DATA

VALVE SIZE	APPROX. FLOW COEFF. US GPM	PORT SIZE
1/2"	26	.59
3/4"	50	.78
1"	94	1.00
1-1/2"	260	1.50
2"	480	2.00
2-1/2"	750	2.55
3"	1300	3.00
4"	2300	4.00

OPERATING DATA

C84/C99/CD84 PRESSURE TEMPERATURE DATA

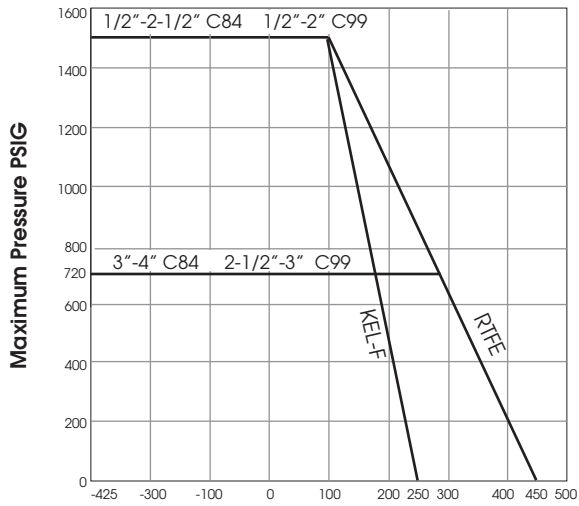

C50 SEAT PRESSURE TEMPERATURE DATA

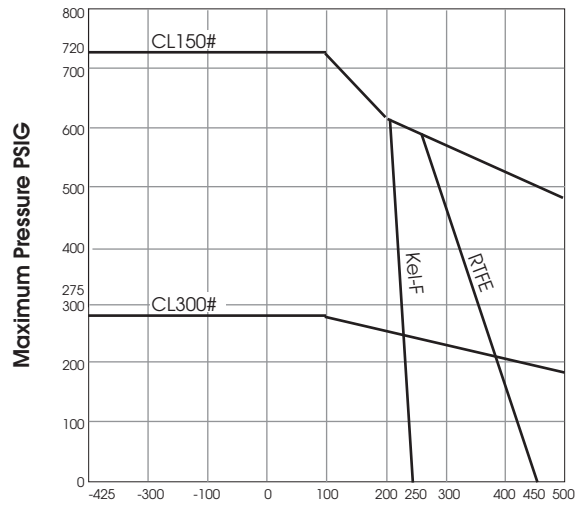

BREAKAWAY TORQUE*

SIZE	C84/CD84	C99	C50-150#	C50-300#
1/2"	55	80	150	160
3/4"	80	195	170	215
1"	195	395	215	310
1-1/4"	395	700	-	-
1-1/2"	700	1050	400	600
2"	1050	1750	560	850
2-1/2"	1750	2190	875	1310
3"	2190	3500	1560	2250
4"	3500	-	3125	3690

* BASED ON MAXIMUM LINE PRESSURE, AT MINIMUM TEMPERATURE.

HOW TO ORDER

VALVE SIZE	VALVE SERIES	BODY, STEM & BALL	ENDS	SEATS	SEALS	ENDS	OPTIONS
1/2" 3/4" 1" 1-1/4" 1-1/2" 2" 2-1/2" 3" 4" (*C84 Only)	C84 Standard Port C99 Full Port	6 = 316 Stainless Steel	6 = 316L Stainless Steel 1 = Bronze	K = KEL-F® R = RTFE	M = TFM T = TFE	IPS TE = Threaded TEB = Threaded BSPT BW = Butt Weld SCH 5, 10, 40, 80 SW = Socket Weld 1 = 150# Flanged 3 = 300# Flanged TUBE ENDS IE = Instrumentation Ends BE = Tube Buttweld BTE = Tube Extended Buttweld	GO = Gear Operator NB = Non Extended Bonnet** SB = Special Extended Length OH = Oval Handle ** Valves available without Bonnet Extension, for intermittent Cryogenic service.

3/4" C84 6 6 K M TE FS

HOW TO ORDER

VALVE SIZE	VALVE SERIES	BODY, STEM & BALL	ENDS SIDE & BOTTOM	SEATS	SEALS	ENDS	BALL CONFIGURATIONS	OPTIONS
1/2" 3/4" 1" 1-1/2" 2" 2-1/2" 3" 4"	CD84 (DIVERTERS)	6 = 316 Stainless Steel	6 = 316L Stainless Steel 1 = Bronze	K = KEL-F® R = RTFE	M = TFM T = TFE R = RTFE	IPS TE = Threaded TEB = Threaded BSPT BW = Butt Weld SCH 5, 10, 40, 80 SW = Socket Weld 1 = 150# Flanged 3 = 300# Flanged TUBE ENDS IE = Instrumentation Ends BE = Tube Buttweld BTE = Tube Extended Buttweld	P1 P2	GO = Gear Operator NB = Non Extended Bonnet** SB = Special Extended Length OH = Oval Handle ** Valves available without Bonnet Extension, for intermittent Cryogenic service.

3/4" CD84 6 6 K M TE P1 FS

HOW TO ORDER

VALVE SIZE	SERIES	VALVE CLASS	ALLOY	SEATS	OPTIONS
1/2" 2" 3/4" 2-1/2" 1" 3" 1-1/4" 4" 1-1/2"	C50	11 = 150# 33 = 300#	6 = 316 Stainless Steel	K = KEL-F® R = RTFE	GO = Gear Operator NB = Non Extended Bonnet** SB = Special Extended Length OH = Oval Handle ** Valves available without Bonnet Extension, for intermittent Cryogenic service.

3/4" C50 11 6 K FS

SHARPE® VALVES

A Division of Smith-Cooper International, LLC

Toll-Free 1-877-7SHARPE
(877) 774-2773
Fax: (708) 562-9250
E-Mail: info@sharpevalves.com
www.sharpevalves.com
1260 Garnet Drive
Northlake, Illinois 60164 U.S.A.