

SHARPE® VALVES

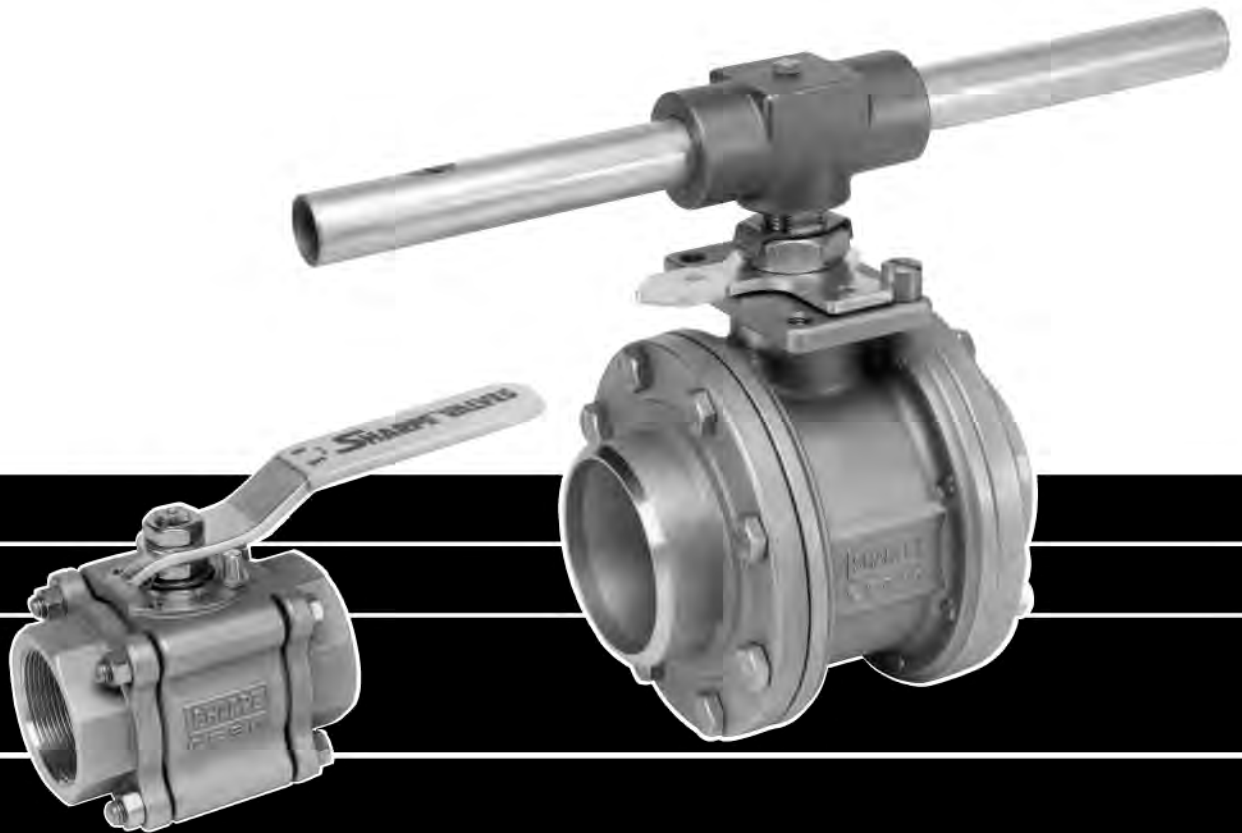

**SERIES CL
CHLORINE BALL VALVES**

SHARPE® HIGH PERFORMANCE CHLORINE BALL VALVES

Sharpe® Series 84/99/50 Ball Valves offer as standard features advantages that other valve manufacturers offer only as costly extras. This is the Sharpe® advantage.

STANDARD FEATURES

Valves meet specifications of Chlorine Institute Pamphlet 6, Piping Systems for Dry Chlorine

Pressure relief hole in side of ball

Relief hole in stem slot

Live load stem packing (Belleville Washers)

Visual position indicator

Special cleaning

Special packing

Available in a variety of material combinations

Series 84/99

Bottom Entry Stem

High Cycle Stem Packing

Fully Encapsulated Body Seals
(Series 84/99)

Integral Mounting Pad

Lockable Handle

Slotted Seat Design

Traceability

ADVANTAGES

Insures proper construction, testing and packaging in appropriate service conditions.

Upstream vent for excessive valve cavity pressure in closed position.

Equals valve cavity pressure and line pressure in open position.

Provides long intervals between stem packing adjustments, decreasing emissions through the packing.

Provides easy identification of valve position

Ready to use in critical applications

Keeps the valve in Factory-new condition until it is to be installed.

Fill most Chlorine Service applications from the inventory at Sharpe® Valves, variety of end connections. (84/99)

In-line serviceable swing-out center section allows easy access to internal valve components without disturbing alignment of pipe. Functions as both valve and union. Prevents accidental removal of stem under pressure.

Self adjusts with pressure and temperature fluctuations. Blow-out proof helps prevent accidents and injuries.

Peek and Nova* thrust bearings and stem seals extend valve cycle life over conventional ball valves and are the best choice for actuation.

Allows valve ends to be welded in line without disassembly, saving costly labor time. Also prevents seal ruptures in high pressure or steam applications.

Ideal for actuation. Centering lip feature assures precise alignment of bracket, stem and coupler. Allows for secondary containment unit to be added when necessary.

All Sharpe® Series CL Valves meet OSHA standards with locking device. Keeps valves from being opened or closed accidentally.

Relief slots help equalize body pressure, reduce torque and assure leak-tight sealing. Seats also provide a wiping action that cleans ball and seats each time valve is cycled.

Heat numbers are provided on all valve bodies and ends. CMTR's (certified mill test reports) are available upon request.

* Carbon and Graphite Filled Teflon®

SERIES CL84 VALVE PARTS AND IDENTIFICATION

1/4", 3/8", 1/2"

3/4" - 2-1/2"

3" - 4"

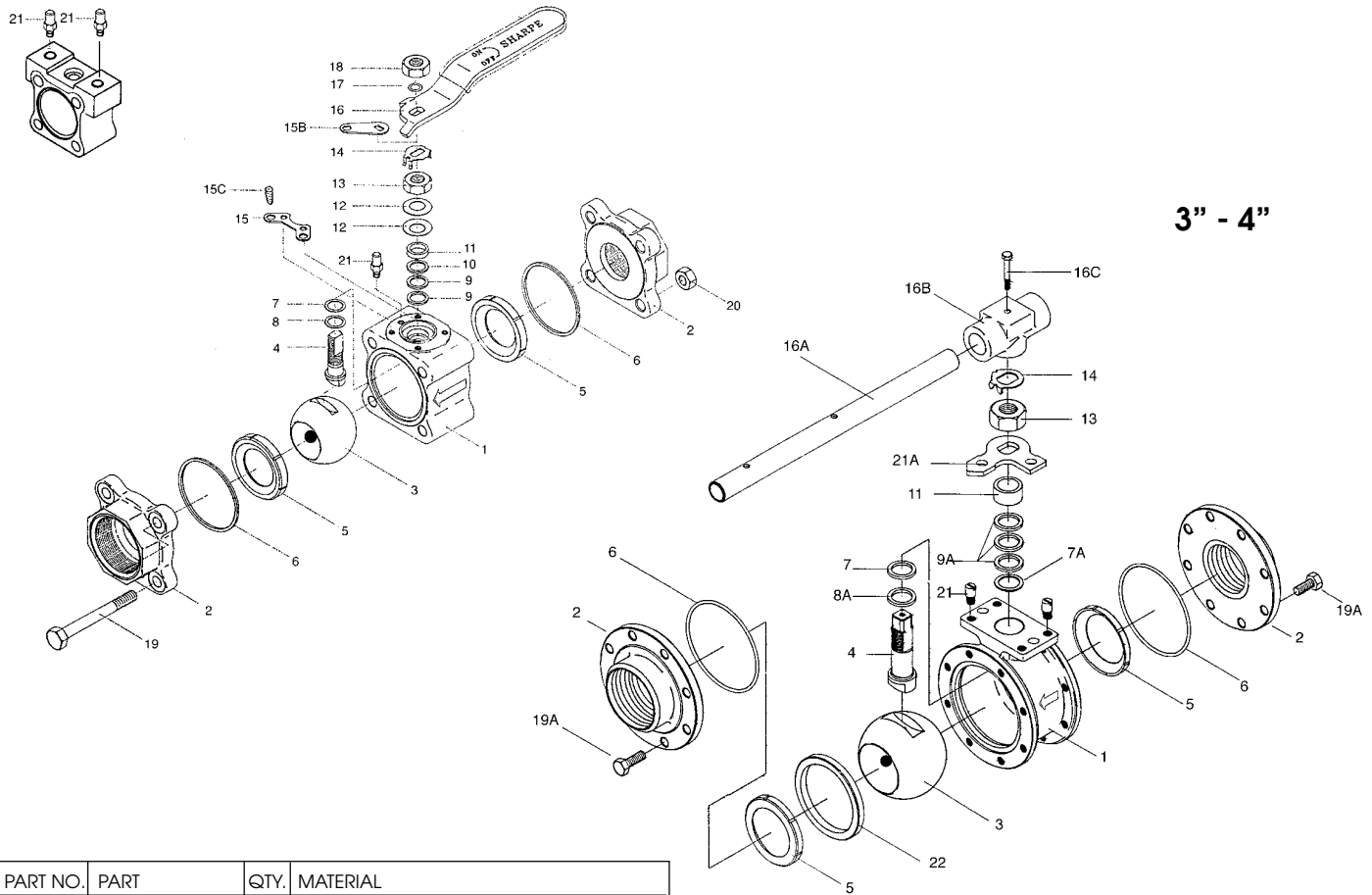

PART NO.	PART	QTY.	MATERIAL
1	Body	1	Carbon Steel ASTM A216 WCB Hastelloy C ASTM A494 Type CW-12MW Monel ASTM A494 GR M35-1
2	Pipe Ends	2	Carbon Steel ASTM A216 WCB Hastelloy C ASTM A494 Type CW-12MW Monel ASTM A494 GR M35-1
3	Ball	1	Monel Hastelloy C
4	Stem	1	Monel Hastelloy C
5	Valve Seat	2	TFE Nova* Reinforced TFE TFM
6	Body Seal	2	TFE Graphoil TFM
7	Thrust Bearing	1	Nova*
7A	Stem Location Ring (3" & 4")	1	Stainless Steel
8	Thrust Bearing	1	Peek
8A	Thrust Bearing	1	Nova*
9	Stem Packing	2	Nova*
9A	Stem Packing (3" & 4")	3	Nova*
10	Seal Protector	1	Peek
11	Gland Packing	1	Stainless Steel
12	Belleville Washer	2	Stainless Steel
13	Packing Nut	1	Stainless Steel

PART NO.	PART	QTY.	MATERIAL
14	Lock Tab	1	Stainless Steel
15	Lower Lock Latch	1	Stainless Steel
15B	Upper Lock Latch Bolt	1	Stainless Steel
15C	Latch Bolt	1	Stainless Steel
16	Handle (1/4"-2")	1	Stainless Steel
16A	Wrench (3" & 4")	1	Cad Plate Carbon Steel
16B	Wrench Block	1	Stainless Steel
16C	Hex Head Bolt	1	Stainless Steel
17	Lock Washer	1	Stainless Steel
18	Handle Nut (1/4"-2")	1	Stainless Steel
19	Body Bolts	4	Stainless Steel
19A	Body Connector Nut	8	Stainless Steel
20	Nuts	4	Stainless Steel
21	Stop Pin (1/4"-1/2")	1 2	Stainless Steel Stainless Steel
21A	Stopper	1	Stainless Steel
22	Seat Retainer	1	Stainless Steel

* Nova: Carbon and Graphite Filled Teflon

SERIES CL99 VALVE PARTS AND IDENTIFICATION

1/4", 3/8"

1/2" - 2"

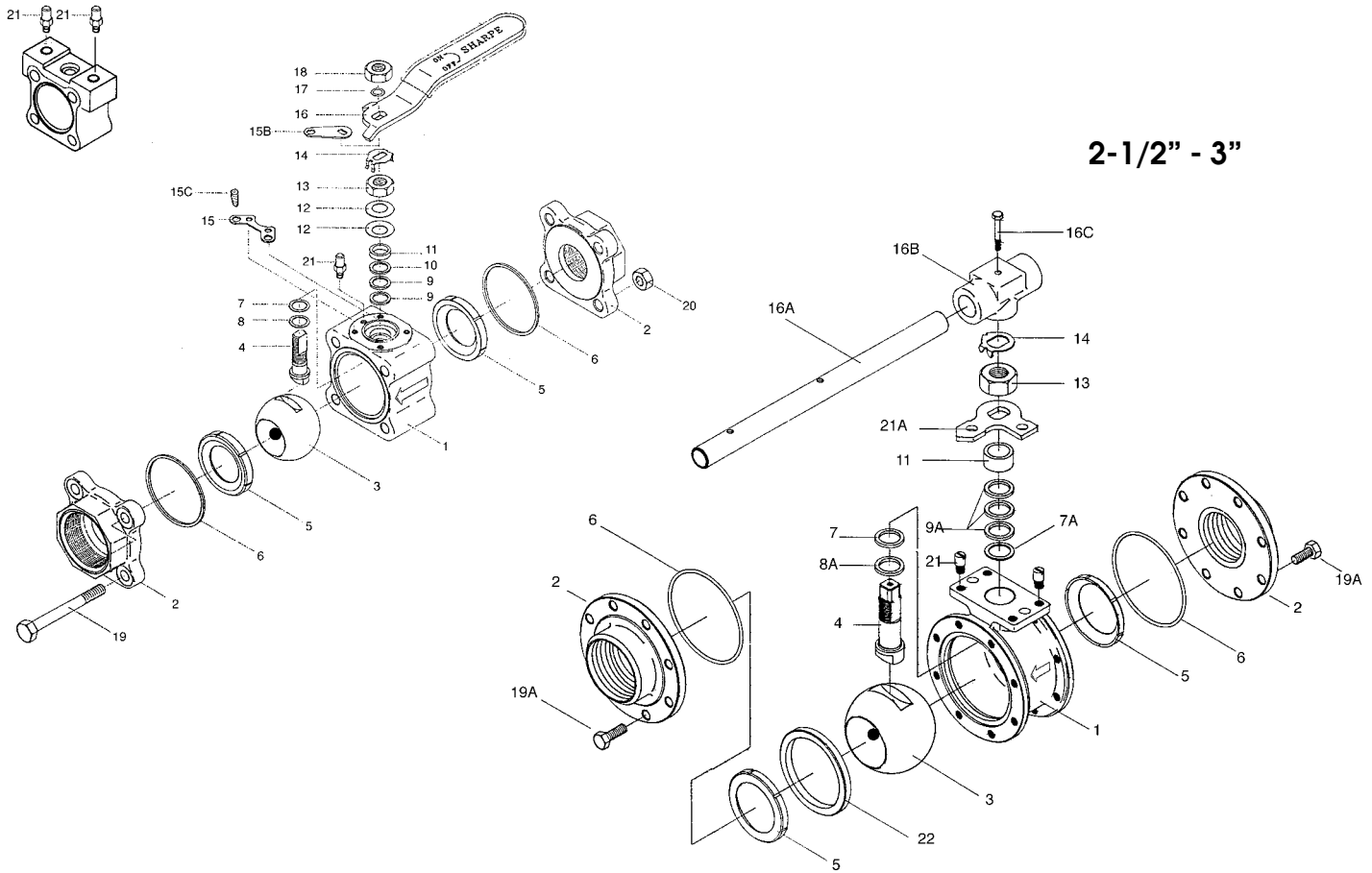

2-1/2" - 3"

PART NO.	PART	QTY.	MATERIAL
1	Body	1	Carbon Steel Hastelloy C Monel
2	Pipe Ends	2	Carbon Steel Hastelloy C Monel
3	Ball	1	Monel Hastelloy C
4	Stem	1	Monel Hastelloy C
5	Valve Seat	2	TFE Nova*
6	Body Seal	2	TFE TFM Graphoil
7	Thrust Bearing	1	Nova*
7A	Stem Location Ring (3" & 4")	1	Stainless Steel
8	Thrust Bearing	1	Peek
8A	Thrust Bearing	1	Nova*
9	Stem Packing	2	Nova*
9A	Stem Packing (3" & 4")	3	Nova*
10	Seal Protector	1	Peek
11	Gland Packing	1	Stainless Steel
12	Belleville Washer	2	Stainless Steel
13	Packing Nut	1	Stainless Steel
14	Lock Tab	1	Stainless Steel

PART NO.	PART	QTY.	MATERIAL
15	Lower Lock Latch	1	Stainless Steel
15B	Upper Lock Latch Bolt	1	Stainless Steel
15C	Latch Bolt	1	Stainless Steel
16	Handle (1/4"-2")	1	Stainless Steel
16A	Wrench (3" & 4")	1	Cad Plate Carbon Steel
16B	Wrench Block	1	Stainless Steel
16C	Hex Head Bolt	1	Stainless Steel
17	Lock Washer	1	Stainless Steel
18	Handle Nut (1/4"-2")	1	Stainless Steel
19	Body Bolts	4	Stainless Steel
19A	Body Connector Nut	8	Stainless Steel
20	Nuts	4	Stainless Steel
21	Stop Pin (1/4"-1/2")	1 2	Stainless Steel Stainless Steel
21A	Stopper	1	Stainless Steel
22	Seat Retainer	1 1	Stainless Steel Carbon Steel

* Nova: Carbon and Graphite Filled Teflon

SERIES CL50

VALVE PARTS AND IDENTIFICATION

CLASS 150# and 300# BLOW OUT PROOF STEM LOCKING DEVICE

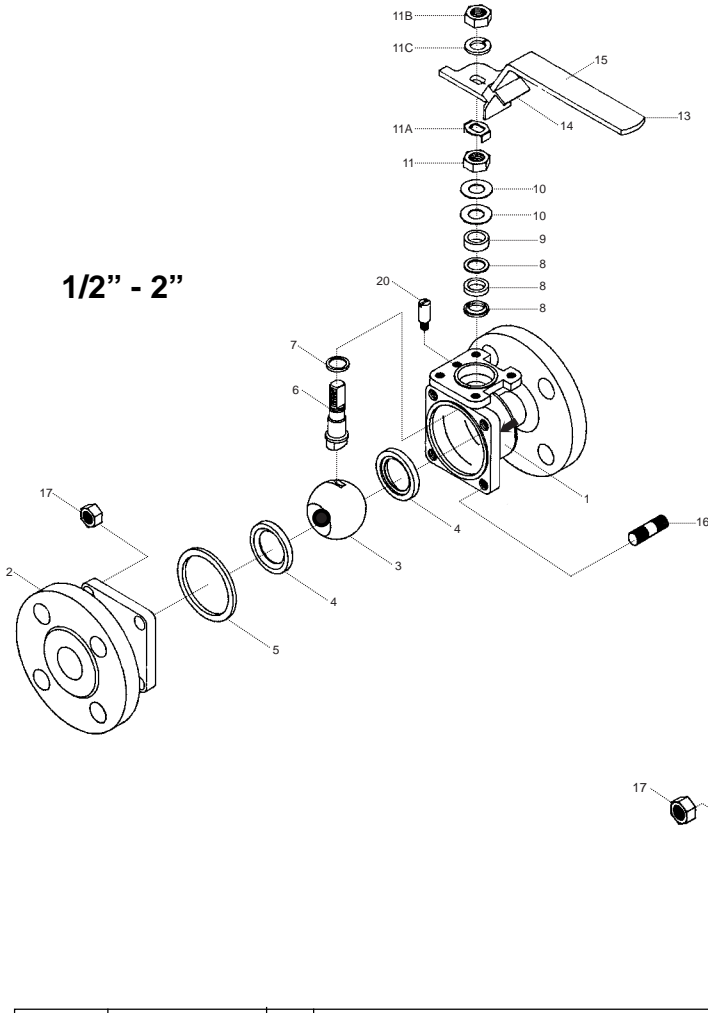

APPLICABLE STANDARDS	
Shell Wall Thickness	ANSI B 16.34
Face to Face Dimensions	ANSI B 16.10
Flange Dimensions	ANSI B 16.5
Tests	ANSI B 16.34 API 598
Basic Design	API 608

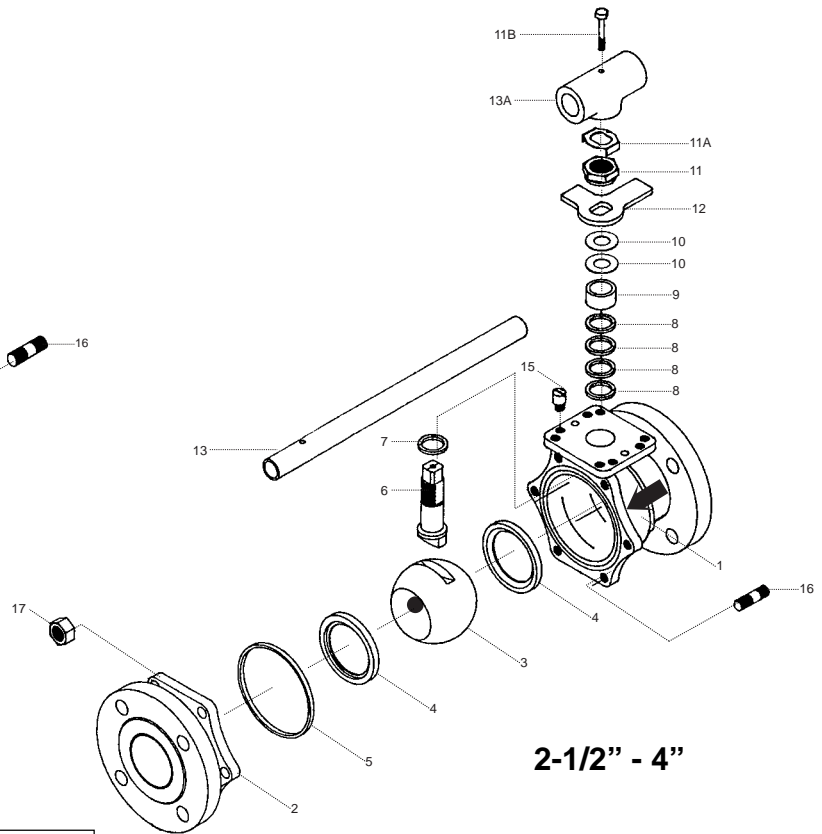

PART NO.	PART	QTY.	MATERIAL
1	Body	1	Carbon Steel ASTM A216 WCB Hastelloy C ASTM A494 Type CW-12MW Monel ASTM A494 GR M35-1
2	End Connector	1	Carbon Steel ASTM A216 WCB Hastelloy C ASTM A494 Type CW-12MW Monel ASTM A494 GR M35-1
3	Ball	1	Monel Hastelloy C
4	Seat	2	TEFLON® Reinforced TFE NOVA TFM
5	Body Seal	1	TEFLON® Graphoil
6	Stem	1	Monel Hastelloy C
7	Thrust Bearing	2	Reinforced TFE
8	Stem Packing	3/4	Reinforced TFE
9	Gland Packing	1	304 Stainless Steel
10	Belleville Washer (1/2"-4")	2	301 Stainless Steel
11	Packing Nut (1/2"-4")	1	304 Stainless Steel
11A	Lock Tab	1	Stainless Steel
11B	Handle Nut	1	304 Stainless Steel
11C	Lock Washer	1	304 Stainless Steel (1/2"-2")

PART NO.	PART	QTY.	MATERIAL
12	Stopper	1	304 Stainless Steel
12A	Snap Ring	1	Stainless Steel (6"-8")
13	Handle	1	304 Stainless Steel (1/2"-2") Galvanized Steel (2-1/2"-4") Ductile Iron (6"-8")
13A	Wrench Block	1	Stainless Steel
13B	Hex Head Bolt	1	304 Stainless Steel
14	Locking Device (1/2"-2")	1	304 Stainless Steel
15	Sleeve	1	Vinyl
16	Body Stud	SEE* N	A 193 B7 (WCB)
17	Nut	SEE* N	A 193 B8M A 194 2H (WCB)
20	Stop Pin (1/2"-2") (2-1/2"-4")	1 2	304 Stainless Steel 304 Stainless Steel

*See Dimensions

SERIES CL84 DIMENSIONS

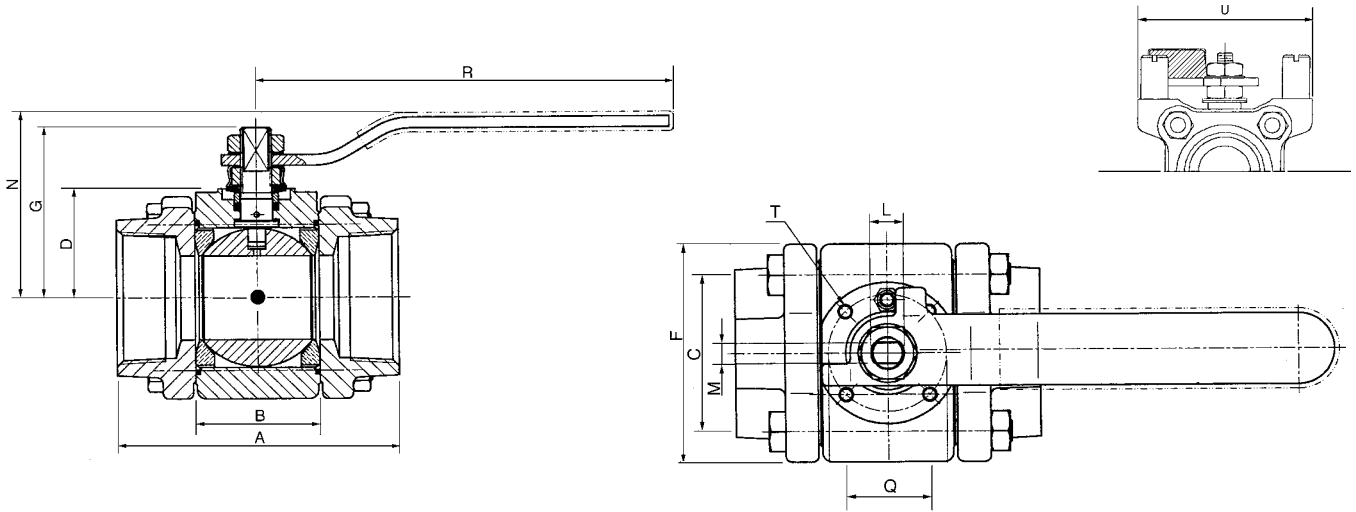

SIZE	A	B	C	D	E	F	G	L	M	N	Q	R	T	1/4", 3/8" & 1/2"	U	V
1/4"	2.54	.813	1.25	.939	-	1.75	1.50	3/8" -24	.22	1.76	-	5.53	1/4" -20	2.37	.28	
3/8"	2.54	.813	1.25	.939	-	1.75	1.50	3/8" -24	.22	1.76	-	5.53	1/4" -20	2.37	.28	
1/2"	2.54	.813	1.25	.939	-	1.75	1.50	3/8" -24	.22	1.76	-	5.53	1/4" -20	2.37	.28	
3/4"	2.78	.969	1.50	1.24	1.00	2.05	1.59	3/8" UNF	.22	1.87	1.00	4.50	M5	-	.28	
1"	3.68	1.25	1.75	1.51	1.18	2.42	2.19	7/16" UNF	.30	2.40	1.18	5.75	M5	-	.30	
1-1/4"	4.22	1.63	2.00	1.65	1.18	2.70	2.38	7/16" UNF	.30	2.70	1.18	5.75	M5	-	.30	
1-1/2"	4.55	1.91	2.25	1.71	1.38	3.16	2.88	9/16" UNF	.35	3.16	1.38	7.00	M6	-	.42	
2"	5.00	2.22	2.62	1.87	1.38	3.56	3.06	9/16" UNF	.35	3.35	1.38	7.00	M6	-	.42	

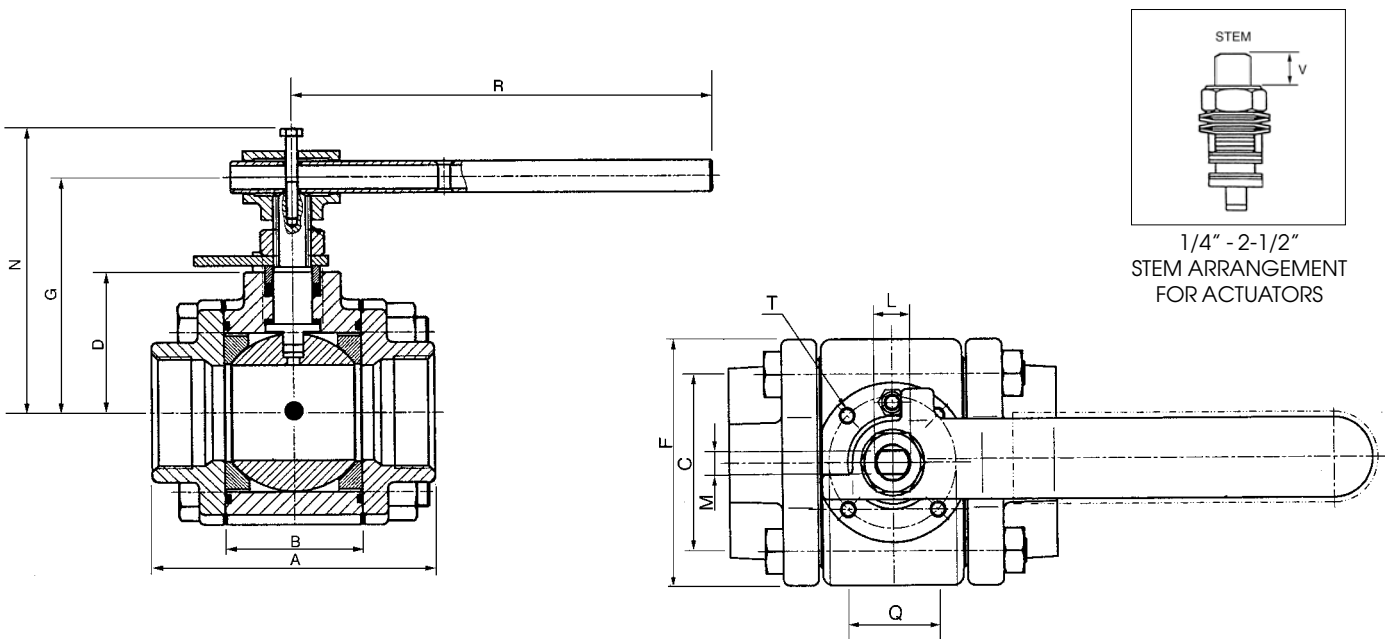

SIZE	A	B	C	D	E	F	G	L	M	N	Q	R	T	1/4", 3/8" & 1/2"	U	V
2-1/2"	5.86	2.86	3.35	2.92	2.75	4.57	4.56	M20	.55	5.58	1.25	10.00	M8	-	.55	

SERIES CL84 DIMENSIONS

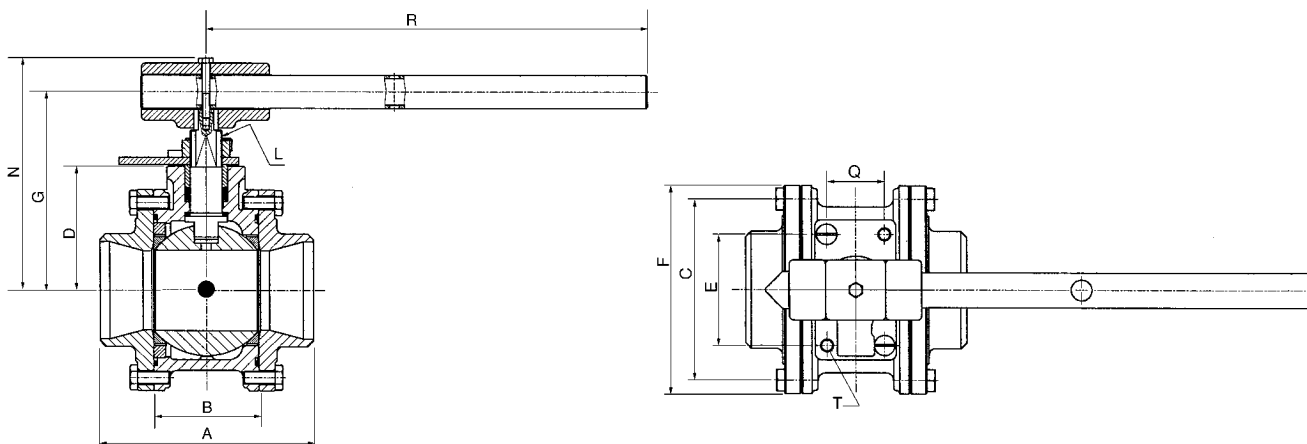

SIZE	A	B	C	D	E	F	G	L	M	N	Q	R	T	1/4", 3/8" & 1/2" U	V
3"	6.66	3.28	5.50	3.87	3.38	6.44	7.25	1.14 UNS	.745	7.25	1.75	13.8	M10	-	.66
4"	8.40	4.28	6.97	4.48	3.38	8.12	7.84	1.14 UNS	.745	7.84	1.75	22.00	M10	-	.66

PERFORMANCE DATA

VALVE SIZE	APPROX. FLOW COEFF. US GPM	EQUIVALENT LENGTH OF SCH. 40 PIPE FEET	APPROX. WEIGHT	PORT SIZE
1/4"	8	1.9	1.20	.44
3/8"	8	1.9	1.20	.44
1/2"	8	1.9	1.20	.44
3/4"	12	6.3	1.70	.56
1"	32	3.1	3.00	.81
1-1/4"	46	6.3	4.00	1.00
1-1/2"	80	4.3	6.00	1.25
2"	120	7.5	8.00	1.50
2-1/2"	240	5.00	25.00	2.00
3"	350	8.3	30.00	2.50
4"	720	10.4	50.20	3.25

Due to ongoing development of our product line, specifications subject to change without notice.

PRESSURE TEMPERATURE DATA

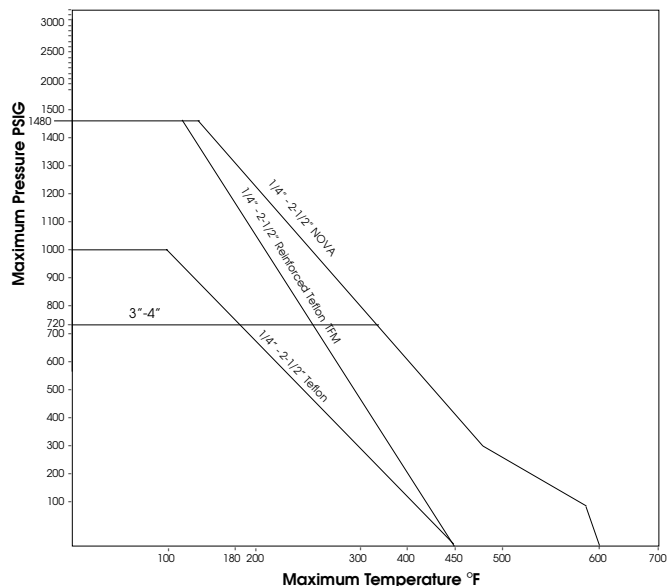

The flow coefficient and pressure loss will be the same as the pipe line they are attached to.

SERIES CL99 DIMENSIONS

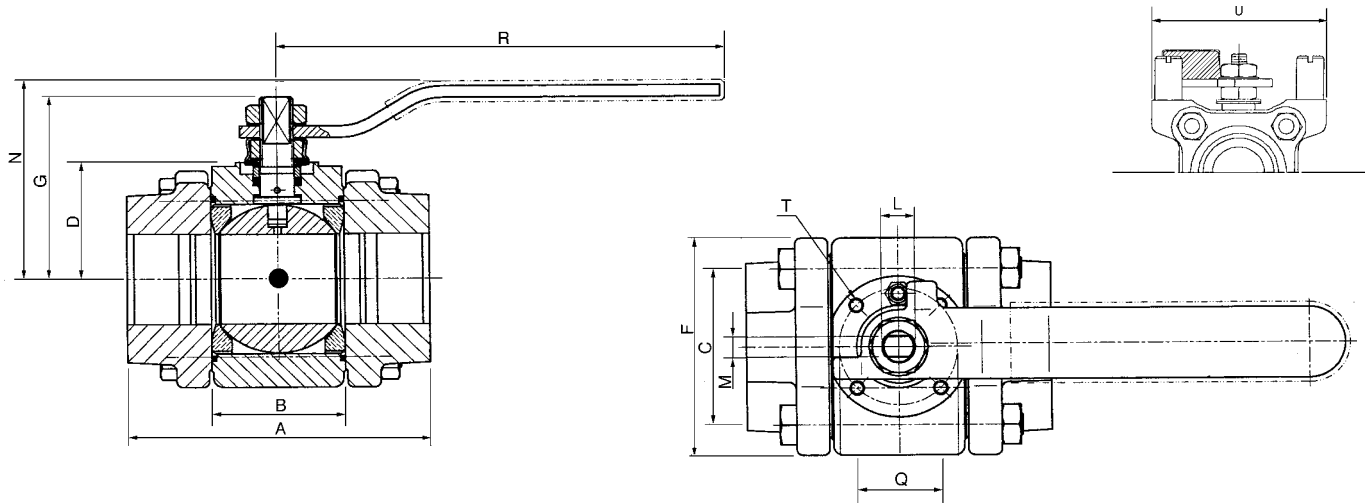

SIZE	A	B	C	D	E	F	G	L	M	N	Q	R	T	1/4", 3/8" & 1/2"	U	V
1/4"	2.54	.813	1.25	.939	-	1.75	1.50	3/8"-24	.22	1.76	-	5.53	-	2.37	.28	
3/8"	2.54	.813	1.25	.939	-	1.75	1.50	3/8"-24	.22	1.76	-	5.53	-	2.37	.28	
1/2"	2.78	.969	1.50	1.24	1.00	2.05	1.59	3/8" UNF	.22	1.87	1.00	4.50	M5	-	.28	
3/4"	3.68	1.25	1.75	1.51	1.18	2.42	2.19	7/16" UNF	.30	2.40	1.18	5.75	M5	-	.30	
1"	4.22	1.63	2.00	1.65	1.18	2.70	2.38	7/16" UNF	.30	2.70	1.18	5.75	M5	-	.30	
1-1/4"	4.55	1.91	2.25	1.71	1.38	3.16	2.88	9/16" UNF	.35	3.16	1.38	7.00	M6	-	.42	
1-1/2"	5.00	2.22	2.62	1.87	1.38	3.56	3.06	9/16" UNF	.35	3.35	1.38	7.00	M6	-	.42	

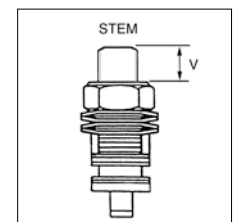
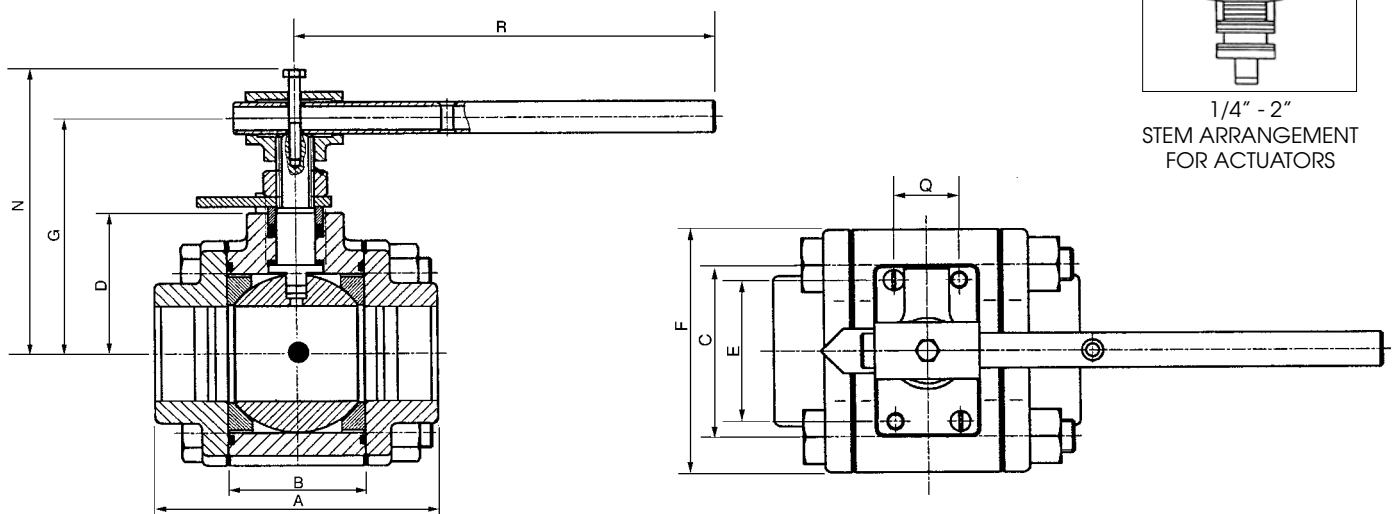

1/4" - 2"
STEM ARRANGEMENT
FOR ACTUATORS

SIZE	A	B	C	D	E	F	G	L	M	N	Q	R	T	1/4", 3/8" & 1/2"	U	V
2"	5.86	2.86	3.35	2.92	2.75	4.57	4.56	M-20	.55	5.58	1.25	10.00	M8	-	0.55	

SERIES CL99 DIMENSIONS

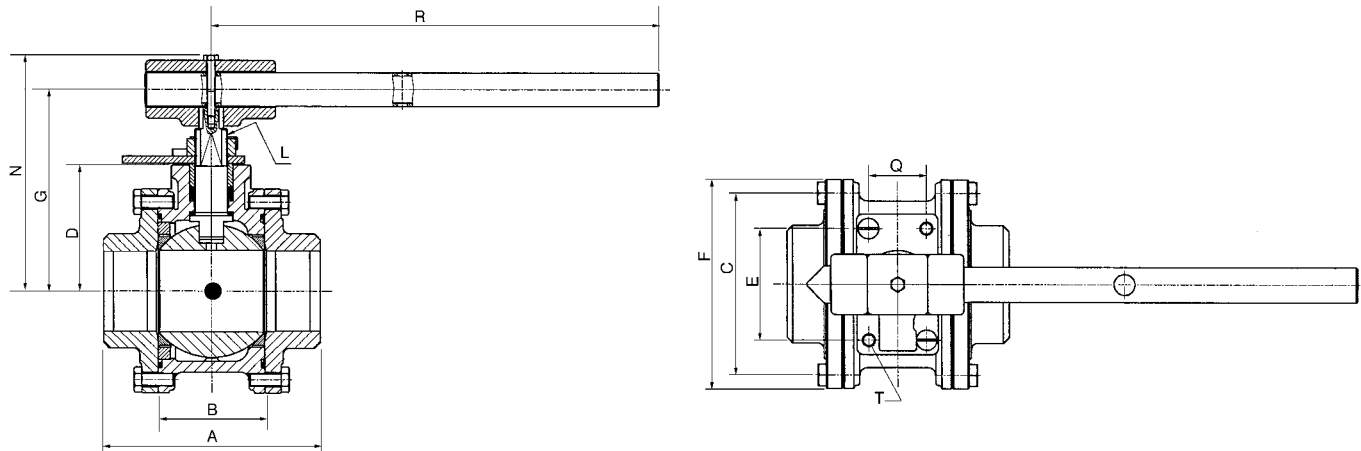

SIZE	A	B	C	D	E	F	G	L	M	N	Q	R	T	1/4", 3/8" & 1/2" U	V
2-1/2"	6.66	3.28	5.50	3.87	3.38	6.44	7.25	1.14 UNS	.745	7.25	1.75	13.8	M10	-	.66
3"	8.40	4.28	6.97	4.48	3.38	8.12	7.84	1.14 UNS	.745	7.84	1.72	22.00	M10	-	.66

PERFORMANCE DATA

VALVE SIZE	APPROX. FLOW COEFF. US GPM	EQUIVALENT LENGTH OF SCH. 40 PIPE FEET	APPROX. WEIGHT	PORT SIZE
1/4"	8	.9	1.8	.44
3/8"	8	.9	1.8	.44
1/2"	38	1.4	1.8	.56
3/4"	71	1.0	3.0	.81
1"	110	1.9	5.7	1.00
1-1/4"	230	2.1	6.2	1.25
1-1/2"	350	2.1	7.5	1.50
2"	600	2.1	29.0	2.00
2-1/2"	780	2.1	32	2.50
3"	1200	3.0	50.3	3.25

Due to ongoing development of our product line, specifications subject to change without notice.

PRESSURE TEMPERATURE DATA

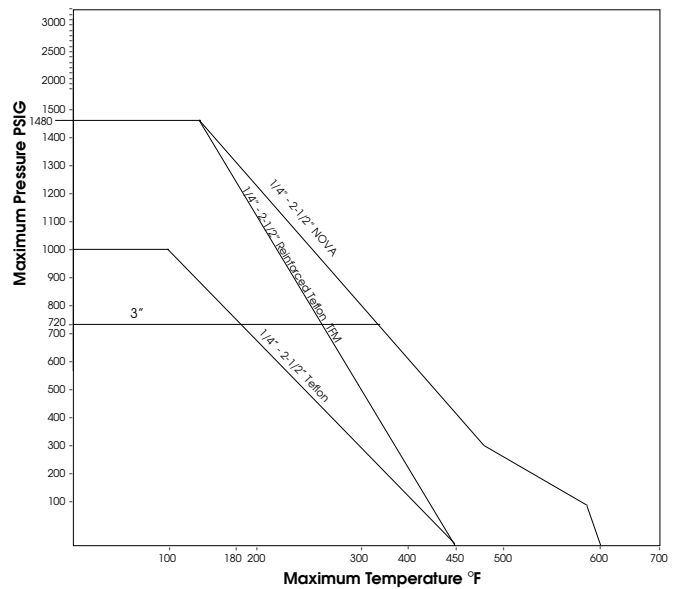

The flow coefficient and pressure loss will be the same for valves as the pipe line they are attached to.

SERIES CL50 DIMENSIONS

1/2" - 2"

2-1/2" - 4"

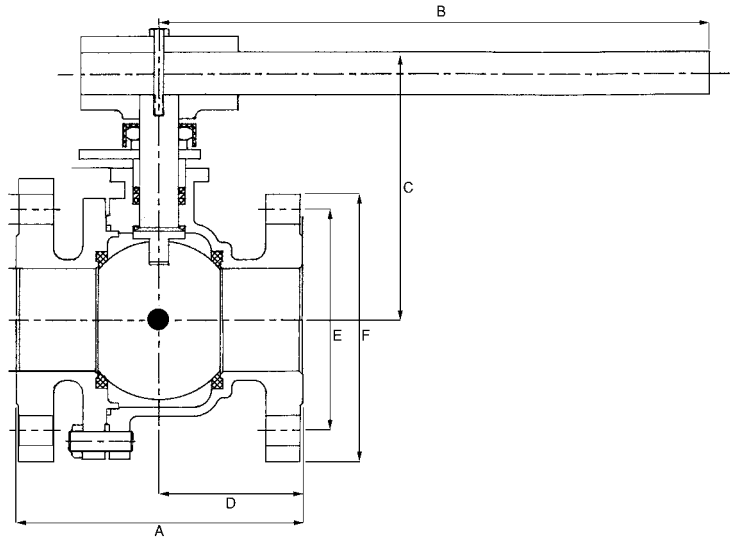
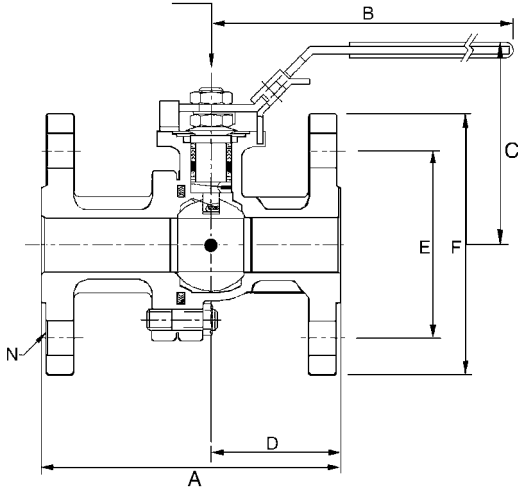

SIZE	A		B		C		D		E		F	
	150#	300#	150#	300#	150#	300#	150#	300#	150#	300#	150#	300#
1/2"	4.25	5.50	4.75	4.75	3.60	3.60	1.80	2.64	2.38	2.62	3.50	3.75
3/4"	4.62	6.00	4.75	4.75	3.75	3.75	2.00	2.94	2.75	3.25	3.85	4.60
1"	5.00	6.50	6.22	6.22	3.75	3.75	2.12	3.19	3.13	3.50	4.25	4.90
1-1/2"	6.50	7.50	9.00	9.00	4.50	4.50	2.76	3.63	3.56	4.50	5.00	6.15
2"	7.00	8.50	9.00	9.00	4.80	4.80	3.08	4.30	4.75	5.00	6.00	6.50
2-1/2"	7.50	9.50	13.75	13.75	6.70	6.70	3.09	4.90	5.50	5.86	7.00	7.48
3"	8.00	11.12	13.75	13.75	7.00	7.00	3.74	5.40	6.00	6.62	7.48	8.26
4"	9.00	12.00	13.75	13.75	7.70	7.70	4.46	5.94	7.50	7.88	9.01	10.00

SIZE	N		G		H		I		J		K		W	
	150#	300#	150#	300#	150#	300#	150#	300#	150#	300#	150#	300#	150#	300#
1/2"	4	4	1.39	1.39	3/8 UNF	3/8 UNF	0.22	0.22	0.28	0.28	0.63	0.63	M5	M5
3/4"	4	4	1.39	1.39	3/8 UNF	3/8 UNF	0.22	0.22	0.28	0.28	0.63	0.63	M5	M5
1"	4	4	1.39	1.39	7/16 UNF	7/16 UNF	0.30	0.30	0.30	0.30	0.90	0.90	M6	M6
1-1/2"	4	4	1.94	1.94	9/16 UNF	9/16 UNF	0.35	0.35	0.42	0.42	1.18	1.18	M8	M8
2"	4	8	1.94	1.94	9/16 UNF	9/16 UNF	0.35	0.35	0.42	0.42	1.18	1.18	M8	M8
2-1/2"	4	8	2.84	2.84	M20	M20	0.55	0.55	0.55	0.55	1.83	1.83	M10	M10
3"	4	8	2.84	2.84	1.14 UNS	1.14 UNS	0.745	0.745	0.66	0.66	1.83	1.83	M10	M10
4"	8	8	2.84	2.84	1.14 UNS	1.14 UNS	0.745	0.745	0.66	0.66	1.83	1.83	M10	M10

SERIES CL50 DIMENSIONS

1/2" - 4"

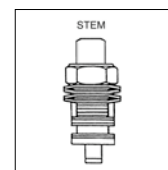
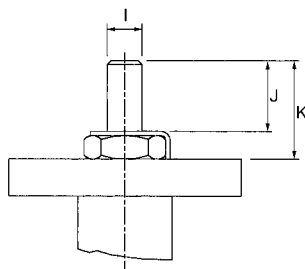
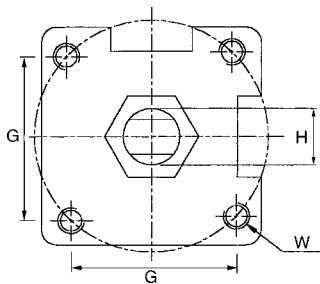

1/2" - 4"
STEM ARRANGEMENT

PERFORMANCE DATA

VALVE SIZE	APPROX. FLOW COEFF. US GPM	APPROX. WEIGHT		PORT SIZE
		150#	300#	
1/2"	26	4	5	.59
3/4"	50	6	7	.78
1"	94	8	10	1.00
1-1/2"	260	15	19	1.50
2"	480	20	33	2.00
2-1/2"	750	36	50	2.55
3"	1300	45	68	3.00
4"	2300	75	96	4.00

Due to ongoing development of our product line, specifications subject to change without notice.

SEAT PRESSURE/ TEMPERATURE RATING

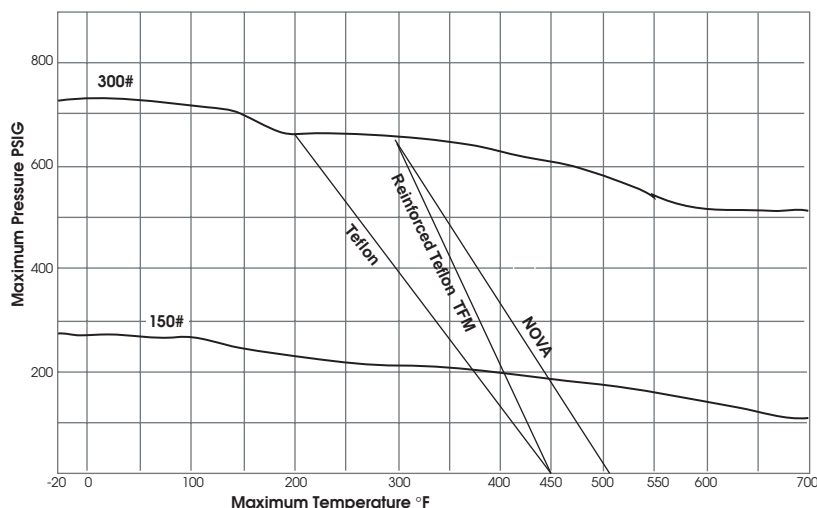

MATERIAL RECOMMENDATIONS

Environment	Service	Maximum Chlorine Conc., ppm of H ₂ O	Recommendations for Ball & Stem Material
Clean - no chlorine in the external environment	In-line	20 ppm	Monel Ball & Stem
		50 ppm	Hastelloy C Ball, Monel Stem
		150 ppm	Hastelloy C Ball & Stem
Environment contains some chlorine	In-line	150 ppm	Hastelloy C Ball & Stem
Much Chlorine in the environment	End of line	150 ppm	Hastelloy C Ball & Stem

HOW TO ORDER (3 PIECE)

VALVE SIZE	VALVE SERIES	BODY & ENDS	BALL & STEM	SEAT	SEAL	ENDS
1/2" 2-1/2" 3/4" 3" 1" 4" 1-1/2" 2"	CL84 CL99	4 = Carbon	3 = Monel 5 = Hastelloy C	T = Teflon® R = Reinforced Teflon N = NOVA M = TFM	T = Teflon® M = TFM G = Graphoil	TE = Threaded Ends (NPT) TEB = Threaded Ends (BSPT) BW = Butt Weld Sch. 5, 10, 40, & 80 SW = Socket Weld

3/4" CL84 4 3 T T TE

HOW TO ORDER FLANGED VALVES

VALVE SIZE	VALVE SERIES	CLASS	BODY	BALL & STEM	SEATS	SEALS
1/2" 2-1/2" 3/4" 3" 1" 4" 1-1/2" 2"	CL50	11 = 150# 33 = 300#	4 = Carbon Steel 3 = Monel 5 = Hastelloy C	3 = Monel 5 = Hastelloy C	T = Teflon® R = Reinforced Teflon N = NOVA M = TFM	T = Teflon® G = Graphoil

3/4" CL50 11 4 3 T T

SHARPE® VALVES

A Division of Smith-Cooper International, LLC

**Toll-Free 1-877-7SHARPE
(877) 774-2773**

Fax: (708) 562-9250

E-Mail: info@sharpevalves.com

www.sharpevalves.com

1260 Garnet Drive

Northlake, Illinois 60164 U.S.A.