

SHARPE[®] VALVES

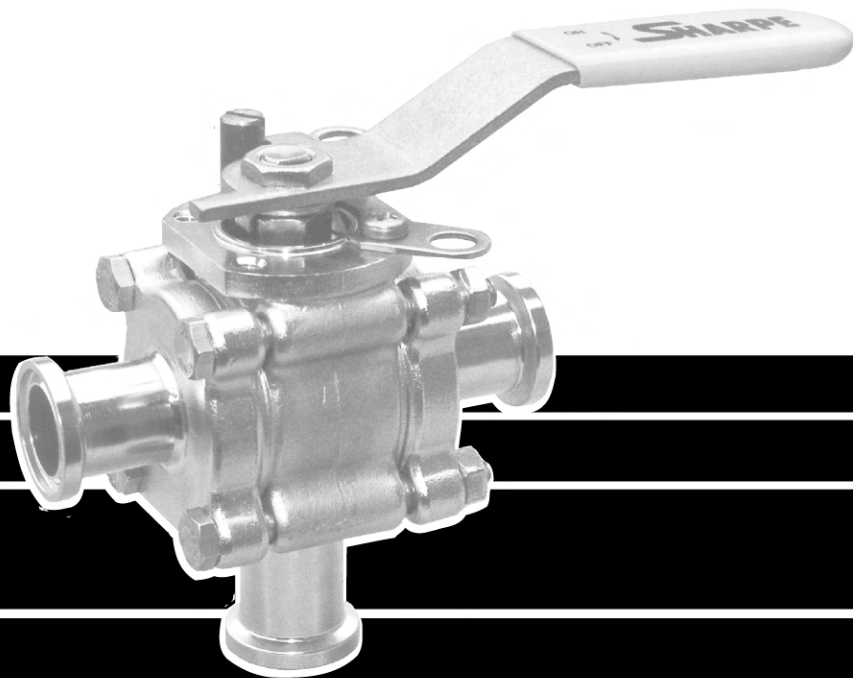

**SERIES D88
HIGH PURITY TUBE FULL PORT
DIVERTER BALL VALVES**

SERIES D88

VALVE PARTS AND IDENTIFICATION

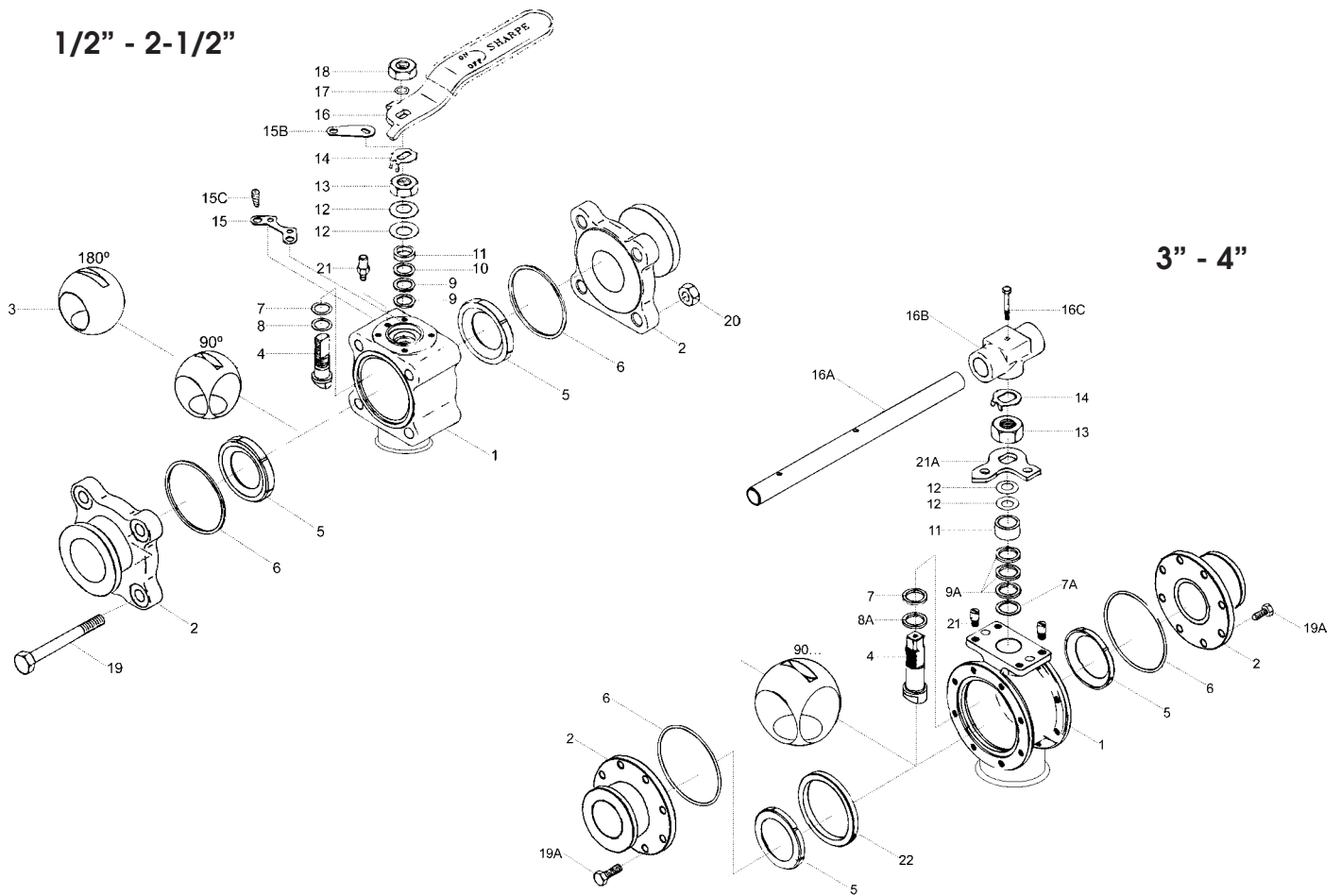

PART NO.	PART	QTY.	MATERIAL
1	Body	1	316L CF3M ASTM 351
2	Pipe Ends	3	316L (CE) ASTM A479 316L (BTE) ASTM A270 316L (BE) ASTM A351 316L (CE) ASTM A351
3	Ball	1	316L
4	Stem	1	316L
5	Valve Seat	2	RTFE / Cavity Filler PTFE / PTFE
6	Valve Seal	2/3	PTFE (3 IN BUTTWELD TUBE EXTENDED)
7	Thrust Bearing	1	Nova*
7A	Stem Location Ring (3" & 4")	1	Stainless Steel
8	Thrust Bearing	1	Peek
8A	Thrust Bearing	1	Nova*
9	Stem Packing	2	Nova*
9A	Stem Packing (3" & 4")	3	Nova*
10	Seal Protector	1	Peek
11	Gland Packing	1	Stainless Steel
12	Belleville Washer	2	Stainless Steel

PART NO.	PART	QTY.	MATERIAL
13	Packing Nut	1	Stainless Steel
14	Lock Tab	1	Stainless Steel
15	Lower Lock Latch	1	Stainless Steel
15B	Upper Lock Latch	1	Stainless Steel
15C	Latch Bolt	1	Stainless Steel
16	Handle (1/4"-2")	1	Stainless Steel
16A	Wrench (2-1/2"-4")	1	Stainless Steel
16B	Wrench Block	1	Stainless Steel
16C	Hex Head Bolt	1	Stainless Steel
17	Lock Washer	1	Stainless Steel
18	Handle Nut (1/4"-2")	1	Stainless Steel
19	Body Bolts (1/2"-2-1/2")	4/8	Stainless Steel
19A	Body Connector Nut (3"-4")	16/24	Stainless Steel
20	Nuts	4/8	Stainless Steel
21	Stop Pin (1/4"-1/2")	1	Stainless Steel
21A	Stopper	2	Stainless Steel
22	Seat Retainer	1	Stainless Steel

* Nova: Carbon and Graphite Filled Teflon

SERIES D88

VALVE PARTS AND IDENTIFICATION

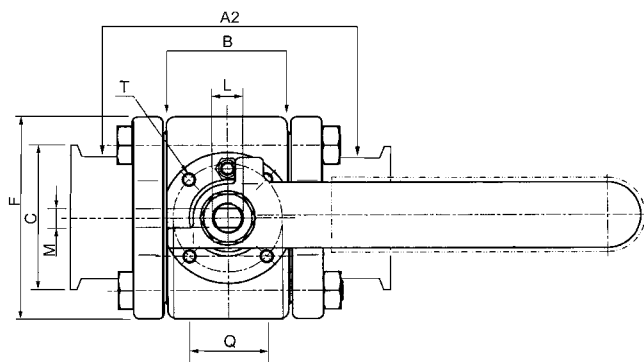
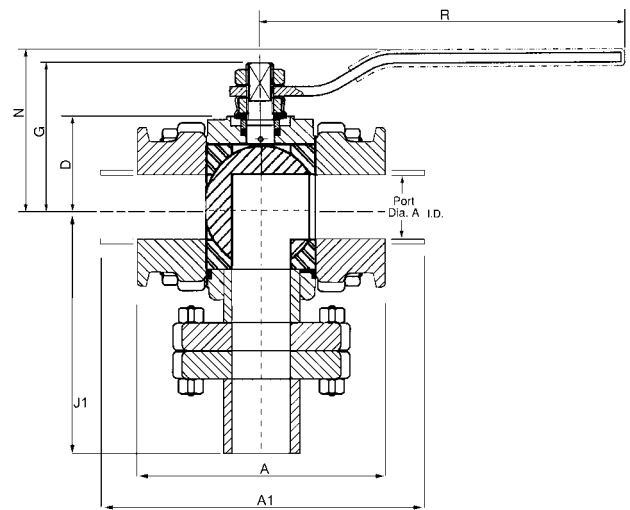
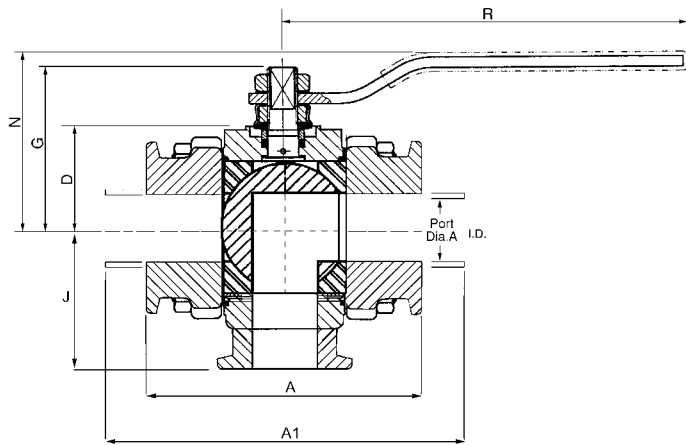

STEM ARRANGEMENT

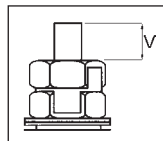

PRESSURE TEMPERATURE DATA

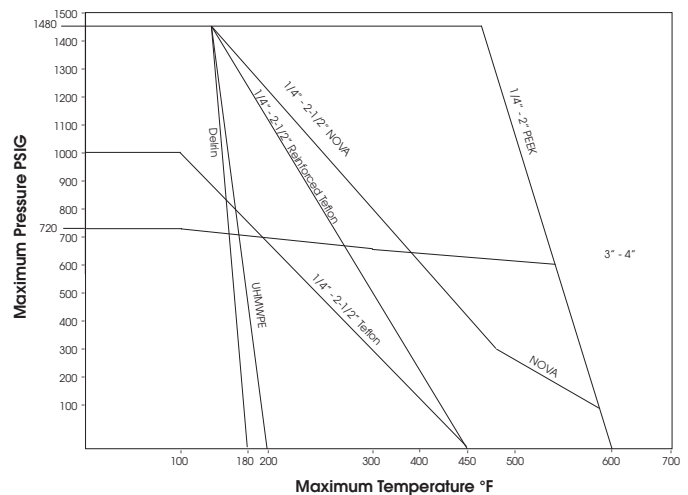

SIZE	A*	A1**	A2	B	J*	J1**	C	D	E	F	G	L	M	N	Q	R	T	V	O.D.	I.D.	SIDE PORT	BOTTOM/CENTER PORT	USGPM CV
1/2"	3.50	5.50	2.50	.97	1.70	4.00	1.25	.939	1.00	1.75	1.50	3/8-24	.22	1.76	1.00	4.50	M5	.28	.50	.37	.37	.37	3.2
3/4"	4.00	6.00	2.73	1.05	1.80	4.60	1.50	1.24	1.00	2.05	1.59	3/8 UNF	.22	1.87	1.00	4.50	M5	.28	.75	.62	.62	.62	5
1"	4.50	6.50	3.62	1.54	1.95	5.10	1.75	1.51	1.18	2.42	2.19	7/16 UNF	.30	2.40	1.18	5.75	M5	.30	1.00	.87	.87	.87	10
1-1/2"	5.50	7.50	4.47	2.13	2.30	5.70	2.25	1.71	1.38	3.16	2.88	9/16 UNF	.35	3.16	1.38	7.00	M6	.42	1.50	1.37	1.37	1.37	24
2"	6.28	8.00	4.90	2.66	2.50	5.80	2.62	1.87	1.38	3.56	3.06	9/16 UNF	.35	3.35	1.38	7.00	M6	.42	2.00	1.87	1.87	1.87	36
2-1/2"	6.75	10.00	5.86	3.20	2.65	7.75	3.35	2.92	2.75	4.57	4.56	M20	.55	5.58	1.25	10.00	M8	.55	2.50	2.37	2.37	2.37	60
3"	6.75	10.00	6.66	3.96	3.20	8.30	5.50	3.87	3.38	6.44	7.25	1.14 UNS	.745	7.25	1.75	13.80	M10	.66	3.00	2.87	2.87	2.87	130
4"	8.25	11.00	8.40	4.75	3.60	9.50	6.97	4.48	3.38	8.12	7.84	1.14 UNS	.745	7.84	1.75	22.00	M10	.66	4.00	3.83	3.83	3.83	240

* A & J = TR

** A1 & J1 = XBTE

SHARPE® VALVES

FLOW PATTERN

The Diverter Valve is designed to accept media through the bottom or side port and direct the flow to either of the two outlet ports. Series D88 is available with two different porting configurations.

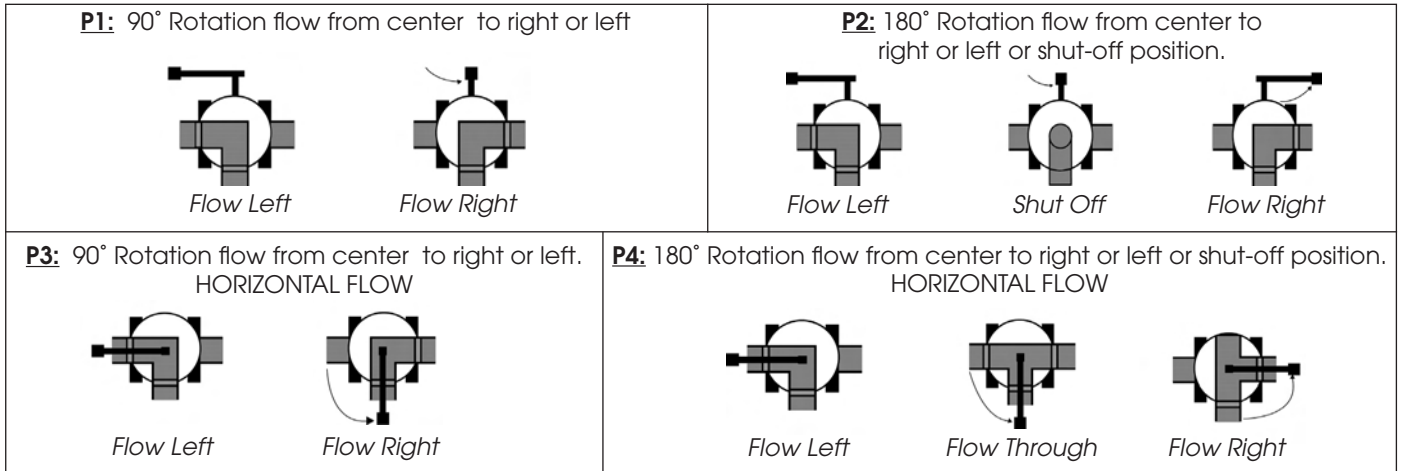

HOW TO ORDER

VALVE SIZE	VALVE SERIES	BODY & ENDS	BALL & STEM	SEAT	SEAL	ENDS	BALL CONFIG.	FINISH	OPTIONS
1/2" 3/4" 1" 1-1/2" 2" 2-1/2" 3" 4"	D88	6-316L	6-316L	R = Reinforced Telfon® T = Teflon® C = Cavity Filler	T = Teflon®	CE = Clamp XBTE = Butt weld Tube Extended BE = Butt weld	P1 P2 P3 P4	1=240 GRIT 2=320 GRIT 3=240 GRIT EP 4=320 GRIT EP	PP=PURG

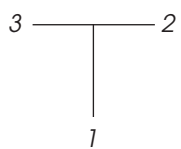

3/4" D88 6 6 T T 1-XBTE P2 1 PP
2-CE
3-CE

Teflon® and Viton® are registered trademarks of E.I. DuPont.

SHARPE® VALVES

A Division of Smith-Cooper International, LLC

Toll-Free 1-877-7SHARPE
(877) 774-2773
 Fax: (708) 562-9250
 E-Mail: info@sharpevalves.com
 www.sharpevalves.com
 1260 Garnet Drive
 Northlake, Illinois 60164 U.S.A.