

SHARPE[®] VALVES

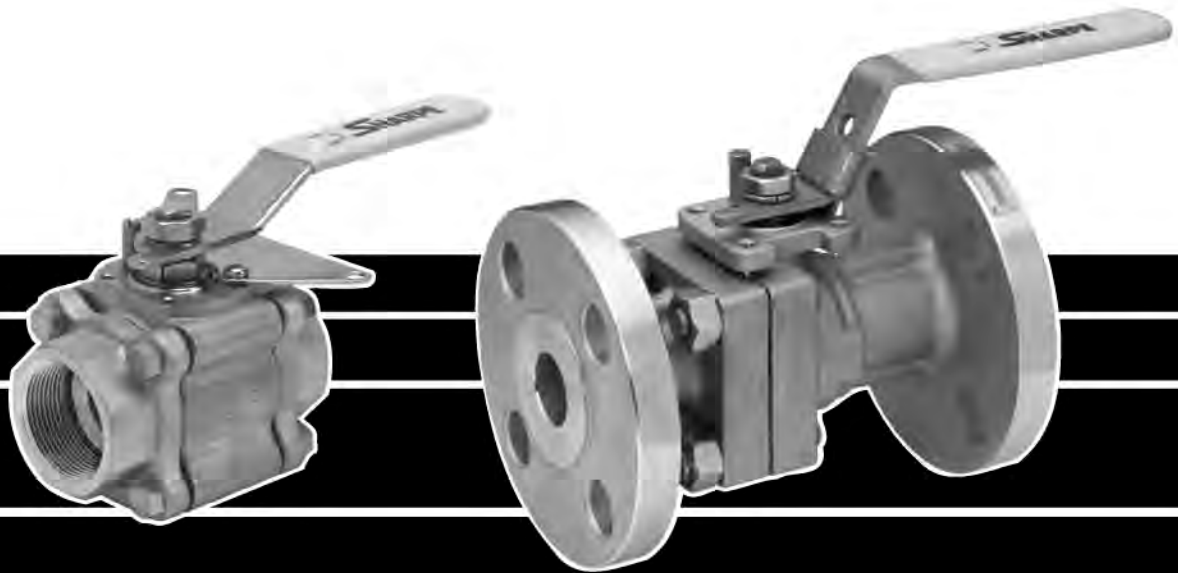

**SERIES M
METAL SEATED BALL VALVES**

SHARPE® METAL SEATED BALL VALVES

In addition to the standard features shown in the specific catalog brochures, the Sharpe Series 84 and 99 three-piece ball valves and Series 50 full-port split body ball valve are now available with metal seats in three different configurations. These new configurations are intended for use in applications requiring resistance to erosion, abrasion, corrosion, and high temperatures beyond the capabilities of the currently available polymeric seat materials. Different seat and seal configurations can be supplied, depending on the specific application. All configurations include the basic combination of a Stainless Steel 316 ball which has been electroless nickel plated (ENP) and SS316 seats hard-faced with Stellite 6. The ball and seats are precision machined and lapped together to provide an extremely tight fit; seat leakage rates equivalent to FCI 70-2, Class V or VI can be provided.

A high-strength SS17-4PH stem is also installed to withstand the higher torques associated with metal seats and the typical applications where they are used. The normal polymeric thrust washer is replaced by a Nitronic 60 thrust bearing. The three metal seat configurations are described below.

Type A Seat Configuration:

This configuration includes the standard metal seat with polymeric seat seals, body seals and stem packing. It is intended for use in highly abrasive or erosive applications where higher temperatures are not an issue. The service temperature limit for this configuration is 450°F (232.2°C).

Type B Configuration:

In this metal seat configuration the polymeric seals are replaced with die-formed flexible graphite seat seals and stem packing. The body seal is spiral wound SS316/flexible graphite in the Series M50; die-formed flexible graphite in the M84/M99. This configuration extends the temperature capability of the metal seated valves to 600°F (316°C), while retaining resistance to abrasion and erosion. This configuration is suitable for On-Off saturated steam service up to 200 PSIG in Class 150 valves, and 600 PSIG in Class 300 valves (carbon steel construction).

Type C Configuration:

This arrangement utilizes a downstream metal seat with a flexible graphite seat seal, as in the Type B, with the upstream seat spring-loaded against the ball to assist in downstream sealing, and to provide compensation for thermal expansion effects at high temperatures. Type C configurations are therefore unidirectional, and a flow direction arrow is provided on the valve body. The Type C configuration is suitable for temperatures up to 1000°F (538°C), and is recommended for high temperature fluids and gases, and is suitable for saturated steam to 720 PSIG.

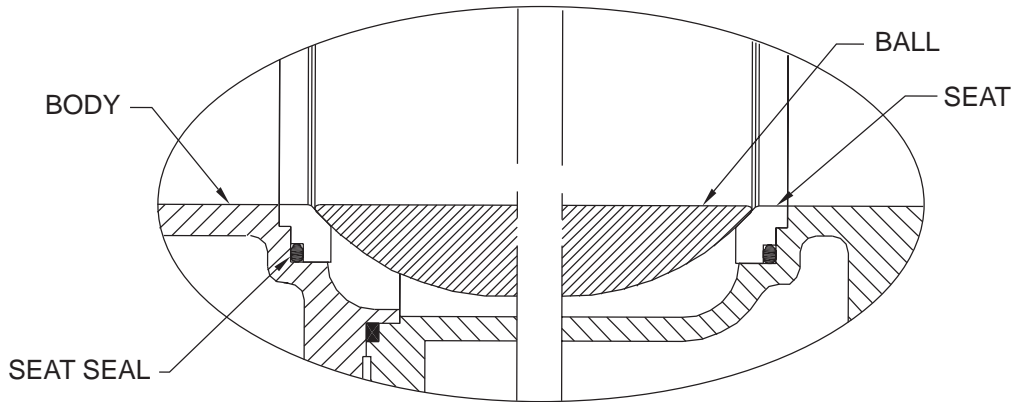

METAL SEAT - TYPE A

CLASS V/VI BI-DIRECTIONAL SHUTOFF
 STELLITE 6 HARDFACED SS 316 SEAT
 ELECTROLESS NICKEL COATED BALL
 POLYMERIC SEAT SEALS

TEMPERATURES TO 450°F

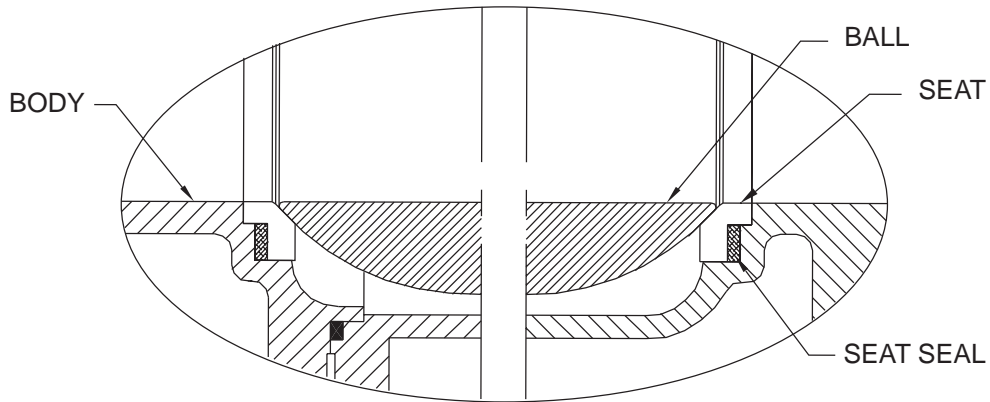

METAL SEAT - TYPE B

CLASS V/VI BI-DIRECTIONAL SHUTOFF
 STELLITE 6 HARDFACED SS 316 SEAT
 ELECTROLESS NICKEL COATED BALL
 FLEXIBLE GRAPHITE SEALS

TEMPERATURES TO 600°F

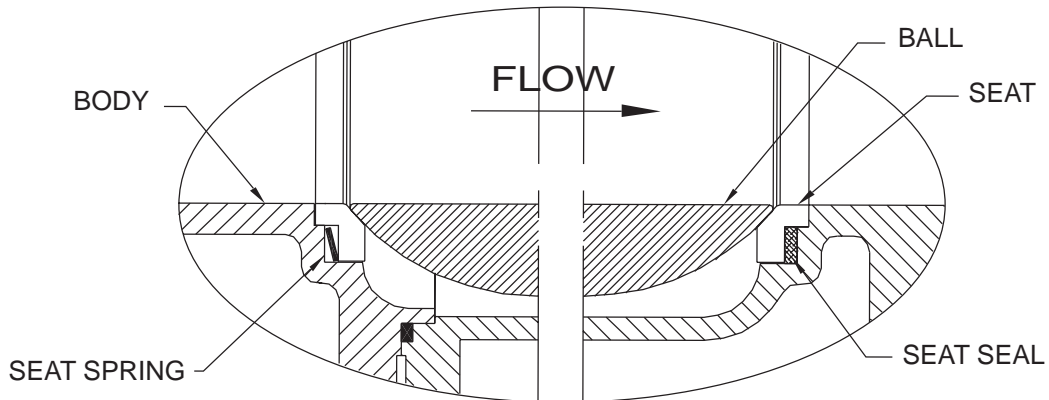

METAL SEAT - TYPE C

SPRING LOADED, UNI-DIRECTIONAL SEAL
 STELLITE 6 HARDFACED SS 316 SEAT
 ELECTROLESS NICKEL COATED BALL
 FLEXIBLE GRAPHITE SEAL/INCONEL SPRING

TEMPERATURES TO 1000°F

**Pressure Temperature Ratings
Metal-seated Ball Valves**

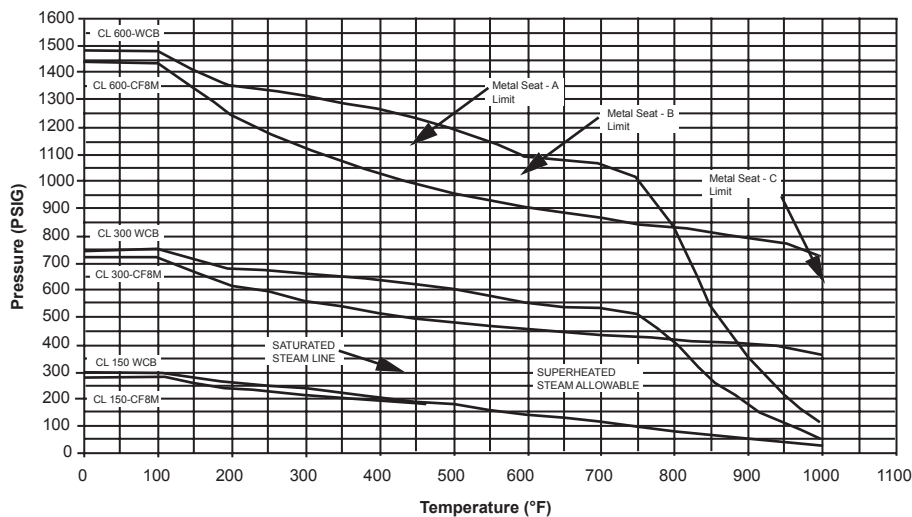

HOW TO ORDER - SERIES M84 AND M99

SIZE	SERIES	BODY & ENDS	TRIM	SEATS	SEALS	ENDS	OPTIONS
1/4" 3/8" 1/2" 3/4" 1" 1-1/4" 1-1/2" 2" 3" 4"	M84 (Standard Port) M99 (Full Port)	4 - Carbon Steel 6 - Stainless Steel	6 - Stainless Steel (17-4PH stem)	A - Type A B - Type B C - Type C	T - TFE G - Grafoil	TE - Threaded NPT/ SW - Socket Weld BW - Butt Weld 1 - CL150RF Flange 3 - CL300 RF Flange 6 - CL600 RF Flange	E = Extended Stem D = Leak Detection Stem GO = Gear Operator A = Nace L = Lockable Extended Stem

1-1/2" M84 6 6 A G SW

SERIES M50

SIZE	SERIES	CLASS	BODY MATERIAL	TRIM	SEATS	SEALS	OPTIONS
1/2" 3/4" 1" 1-1/2" 2" 2-1/2" 3" 4" 6" 8" 10" 12"	M50 (Full Port)	11 - CL150 33 - CL300 66 - CL600	4 - Carbon Steel 6 - Stainless Steel	6 - Stainless Steel (17-4PH stem)	A - Type A B - Type B C - Type C	T - TFE G - Grafoil	E = Extended Stem D = Leak Detection Stem GO = Gear Operator A = Nace L = Lockable Extended Stem

1-1/2" M50 66 6 A G

SHARPE VALVES

A Division of Smith-Cooper International, LLC

Toll-Free 1-877-7SHARPE

(877) 774-2773

Fax: (708) 562-9250

E-Mail: info@sharpevalves.com

www.sharpevalves.com

1260 Garnet Drive

Northlake, Illinois 60164 U.S.A.