



Instrumentation Hand Valves

*Catalog 4190-HV
January 2006*



Contents

Page 3	Introduction	
Page 4/5	Bonnet assembly details	
Page 6/7	Globe style bar stock needle valves (HNV series) 6,000 psig/414 barg	
Page 8/9	Globe style bar stock needle valves (HNV series) 10,000 psig/689 barg	
Page 10/11	Rising plug valves (HRPV series)	
Page 12/13	Multi-port gauge valves (HGV series)	
Page 14/15	Single port gauge valves with vent (HVG series)	
Page 16/17	Outside screw & yoke globe pattern needle valves (HYNV series)	
Page 18	Option and suffix's	
Page 19	Materials and specifications	

Introduction

With years of valve design and development experience Parker Hannifin are able to offer the most comprehensive range of instrument hand valves available to users for a wide variety of markets, industries and applications. Now consolidated into one catalogue Parker is able to offer a simplified system of selection and choice for all Instrument applications and installations.

In addition to producing valves and manifolds Parker also makes twin and single ferrule compression fittings A-LOK® and CPI™ which are used extensively in the oil, gas, petro-chem, power, processing and many other industries. Combining these as an integral part of the valve body users can eliminate pipe threaded connections reducing leak paths and avoiding the use of thread sealant, a frequent menace to instrument and system performance.

For higher pressure ratings up to 15,000 psig Parker can now offer their new MPI™ range of compression fittings.

All the valves offered in this catalogue are available with integral compression ends improving system performance, safety factors, size and weight reduction, simplifying installation and ultimately reducing customer costs.

Continuous product development may from time to time necessitate changes in the details contained in this catalogue. Parker Hannifin reserve the right to make such changes at their discretion and without prior notification.



All dimensions shown in this catalogue are approximate and subject to change.

WARNING

FAILURE, IMPROPER SELECTION OR IMPROPER USE OF THE PRODUCTS AND/OR SYSTEMS DESCRIBED HEREIN OR RELATED ITEMS CAN CAUSE DEATH, PERSONAL INJURY AND PROPERTY DAMAGE.

This document and other information from Parker Hannifin Corporation, its subsidiaries and authorized distributors provide product and/or system options for further investigation by users having technical expertise. It is important that you analyze all aspects of your application and review the information concerning the product or system in the current product catalog. Due to the variety of operating conditions and applications for these products or systems, the user, through its own analysis and testing, is solely responsible for making the final selection of the products and systems and assuring that all performance, safety and warning requirements of the application are met.

The products described herein, including without limitation, product features, specifications, designs, availability and pricing, are subject to change by Parker Hannifin Corporation and its subsidiaries at any time without notice.

Offer of Sale

The items described in this document are available for sale by Parker Hannifin Corporation, its subsidiaries or its authorized distributors. Any sale contract entered into by Parker will be governed by the provisions stated in Parker's standard terms and conditions of sale (copy available upon request).

Globe style bonnet design for HNV, HGV and VG series

1. Positive handle retention design featuring broached square engagement positioned by thread locked grub screw.

2. "T" bar

Ergonomically designed for ease of operation. Anti-tamper and lockable devices can be supplied for on site retro-fit.

4. Gland packing adjuster

For maximum packing stability and performance, simple and easily adjustable for gland wear compensation.

6. Valve Bonnet

Standard construction for maximum pressure rating with replaceable bonnet sealing washer arrangement.

8. Thrust Bush

Anti rotational adjustor bush ensures uniform packing compression, maximising pressure tight sealing and limiting cold flow passages.

10. Bonnet/body washer

Annealed sealing washer to ensure complete atmospheric leakage and allowing on site retro-fit of bonnets with 100% re-sealing assurance.

For safe reliable and repeatable performance

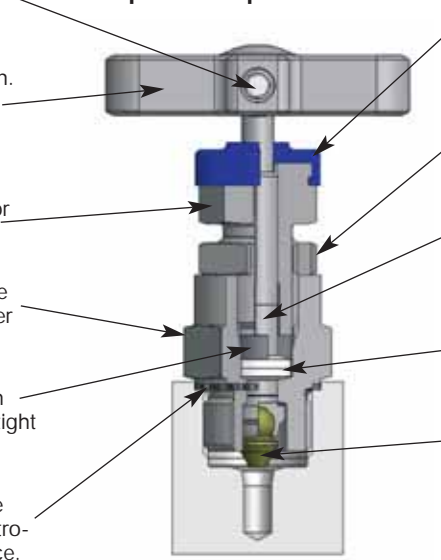

3. Dust Cap

This has a dual purpose, preventing air born debris from contaminating the operating spindle thread and providing colour coded functional identification. Isolate (BLUE).

5. Gland adjuster lock nut

A secure anti vibration locking mechanism to prevent inadvertent gland adjuster loosening.

7. Anti blowout spindle

Designed for low torque operation with high quality micro mirror stem finish for positive gland sealing.

9. Gland packing (adjustable)

Chevron effect dual piece gland packing to provide maximum sealing area contact with minimum gland adjustment.

11. Spindle tip

Self centering, non-rotational tip gives successive positive bubble tight shut off assuring the user of leakage free performance and downstream functional safety.

All metallic standard parts are produced in stainless steel, for alternative materials please refer to page 19. Manifolds produced in other specified materials will be provided with non-wetted parts as standard in stainless steel, this applies to items 1, 2, 4, 5 & 8.

Specification

- Height closed (standard and HP) = 47mm (1.85"). Height open (standard and HP) = 50.3mm (2.00").
- Number of turns open/close - 3.5.
- Stainless steel construction.
- Maximum standard pressure up to 6,000 psig (414 barg).
- Maximum optional pressure up to 10,000 psig (689 barg). See page 8/9.
- Temperature rating -54C to +538C (-65F to +1000F).
- PTFE standard gland packing (Graphoil optional).
- Maximum temperature PTFE 260C (500F).
- Maximum temperature Graphoil 538C (1000F).

Features

- Standard unit throughout hand valve range.
- Operating threads outside washout area.
- Externally adjustable gland.
- Low operating torque.
- Alternative 10,000 psig (689 barg) range available.
- Retro-fit kit for:-
 - Anti-tamper spindle.
 - Panel mounting.
 - Lockable T bar.
 - Handwheel with lockable option.
- Bonnet locking pin to prevent accidental removal fitted as standard.
- Alternative graphoil packing for high temperature performance available.
- Alternative self centering tip materials available for gaseous and aggressive fluids.
- Safety back seated spindle prevents stem blowout and provides secondary back up stem seal.
- Packing below threads to prevent lubricant washout.
- All valves 100% factory tested.
- NACE compliant wetted parts available.
- Optional cleaned and lubricated suitable for Oxygen service.
- Heat code traceable body and bonnet.

Pressure vs temperature

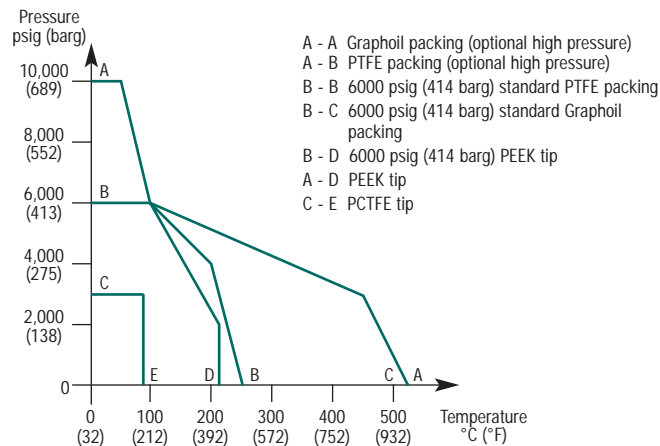

⚠ When selecting products for specific applications users should refer to our notice at the bottom of page 3.

Optional globe style bonnet design for HNV, HGV and VG series

For on-site assembly

The design options below can be simply retrofit to any NV, GV and VG series standard valves. Retrofit kit part numbers are listed next to the illustrated option and all parts will be supplied in stainless steel regardless of the parent body material.







For factory fitted assembly

To obtain factory assembled options the valve part number must be suffixed with the option and function designator. Options can be combined:-

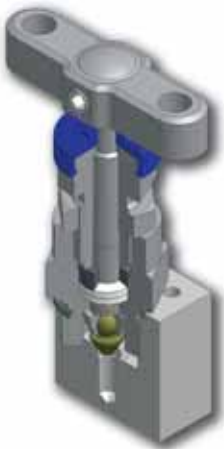
Example HNV*8FFAT – NV series valve, factory fitted with anti-tamper (AT) operating mechanism.

Example HGV*8THL – GV series valve, factory fitted with “T” bar locking plate (THL).

Note: Padlocks for lockable handwheels and “T” bars are not supplied (hole size 6mm/0.24”).

Standard bonnet	T bar handle locking	Anti tamper spindle
	 <p>Retro-fit kit part number KITTHL Factory assembled suffix THL</p>	 <p>For key only - part no. ATHKEY/1 Retro-fit kit part number KITAT without key KITATK with key Factory assembled suffix AT without key ATK with key</p>
Handwheel	Lockable handwheel	*Panel mounting
 <p>Retro-fit kit part number KITHW Factory assembled suffix HW</p>	 <p>Retro-fit kit part number KITLHW Factory assembled suffix LHW</p>	 <p>Retro-fit kit part number KITPM† Factory assembled suffix PM † Panel mount kit for HP: KITPMHP</p>

*Panel mounting hole diameter = 26mm (1.02").
Panel thickness = Max 5mm (0.20") Min 2.3mm (.09").

Globe style bar stock needle valves HNV series (6,000 psig/414 barg)

Purpose

Bar stock needle valves are purpose designed valves for operation with any fluid up to 6,000 psig (414 barg) rating. Complete with standard PTFE gland packing and self centering non rotational tip, gives the user assurance of total in service sealing security. For gaseous application soft tipped optional seating is available. A wide variety of end connectors are offered for all types of installation. NACE compliant materials and oxygen clean are also available along with an extensive list of materials of construction.



Specification

- Standard seat diameter 4mm.
- Optional seat diameter 6mm.
- Cv: 0.35 standard.
- Maximum standard pressure up to 6,000 psig (414 barg).
- Temperature rating -54C to +538C (-65F to +1000F).
- Port sizes up to 1/2" pipe thread and 1/2"/12mm tube compression ends as standard. Optional sizes up to 1" pipe, tube and combination ends can be considered.

Features

- Rolled spindle operating threads.
- Stainless steel construction as standard.
- PTFE packing standard, optional graphite.
- Alternative tip and materials of construction available.
- Self centering non rotating spindle tip for bubble tight shut off.
- Colour coded functional identification.
- Back stop spindle for blowout prevention, and minimal atmospheric leakage.
- Low torque operating T bar handle.
- Externally adjustable gland.
- Panel and base mount option.
- Variety of end connections including integral compression one piece bodies.
- Angled versions available.
- Firesafe option available to API 607 BS 6755 Part 2.
- Dust cap to prevent ingress of contamination to operating thread.
- Bonnet locking pin fitted as standard.
- Angled flow path (option).

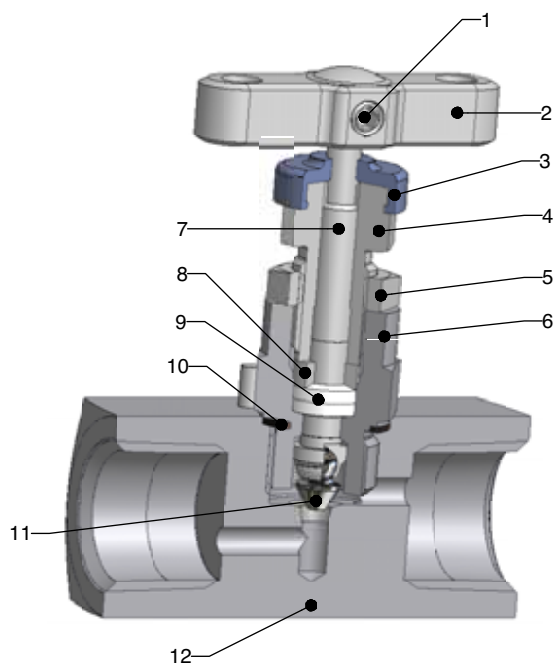

Part description

Item	Description
1	Locked grub screw
2	T bar handle assembly
3	Dust cap/function label
4	Gland adjuster
5	Gland locknut
6	Valve bonnet
7	Anti blowout spindle
8	Thrust bush
9	Gland packing (2)
10	Sealing washer
11	Self centering spindle tip
12	Body

Standard product specification: metal/metal seated, PTFE packed, stainless steel, T bar operation, globe pattern, 6000 psig (414 barg).

Standard range part numbers

Part no.	Inlet	Outlet	Dimension		
	Female	Female	A mm (inch)	B mm (inch)	C mm (inch)
HNV*4FF	1/4 NPT	1/4 NPT	54.0 (2.13")	28.6 (1.13")	79.4 (3.13")
HNV*6FF	3/8 NPT	3/8 NPT	54.0 (2.13")	28.6 (1.13")	79.4 (3.13")
HNV*8FF	1/2 NPT	1/2 NPT	63.5 (2.50")	28.6 (1.13")	79.4 (3.13")
	Male	Female			
HNV*4M4F	1/4 NPT	1/4 NPT	57.8 (2.27")	28.6 (1.13")	79.4 (3.13")
HNV*8M8F	1/2 NPT	1/2 NPT	73.0 (2.87")	28.6 (1.13")	79.4 (3.13")
	A-LOK®	A-LOK®			
HNV*4A	1/4	1/4	67.5 (2.66")	25.4 (1.00")	76.2 (3.00")
HNV*8A	1/2	1/2	76.2 (3.00")	25.4 (1.00")	76.2 (3.00")
HNV*M6A	6mm	6mm	67.5 (2.66")	25.4 (1.00")	76.2 (3.00")
HNV*M12A	12mm	12mm	76.2 (3.00")	25.4 (1.00")	76.2 (3.00")

*Insert material code

Notes for compression ended valves:-

1. For CPI™ change A to Z.
2. "A" dimension given for finger tight nuts and ferrules.
3. Can be offered to comply with latest issue of NACE subject to para. 8.4.1.1.
4. For compression ended valve pressure ratings consult tube ratings table.

Dimension "C" in open position.

Designed to meet pressure/temperature ratings of ANSI Class 2500 where applicable.

For a full list of options and suffix's, [see page 18](#). For a full list of materials and specifications, [see page 19](#).

Pressure vs temperature

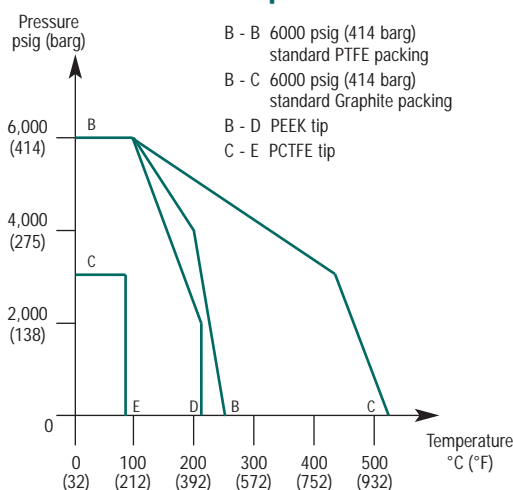

⚠ When selecting products for specific applications users should [refer to our notice at the bottom of page 3](#).

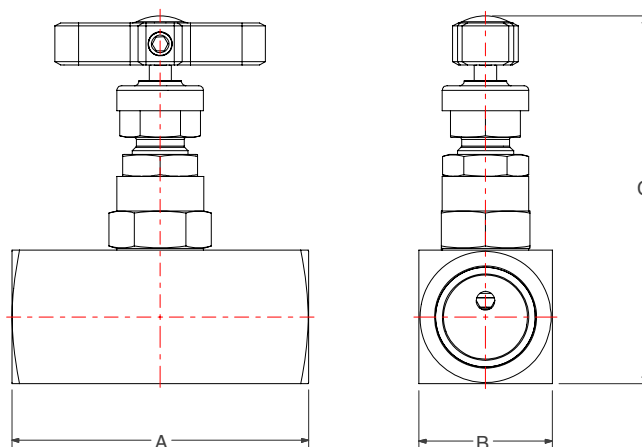

Globe style bar stock needle valves HNV series (10,000 psig/689 barg)

Purpose

Bar stock needle valves are purpose designed valves for operation with any fluid up to 10,000 psig (689 barg) rating. Complete with standard PTFE gland packing and self centering non rotational tip, gives the user assurance of total in service sealing security. For gaseous application soft tipped optional seating is available. A wide variety of end connectors are offered for all types of installation. NACE compliance and oxygen clean are also available along with an extensive list of materials of construction.



Specification

- Standard seat diameter 4mm.
- Optional seat diameter 6mm.
- Cv: 0.35 standard.
- Maximum standard pressure up to 10,000 psig (689 barg).
- Temperature rating -54C to +538C (-65F to +1000F).
- Port sizes up to 1/2" pipe thread and 1/2" MPI™ tube compression ends as standard.
Optional sizes up to 1" pipe, tube and combination ends can be considered.

Features

- Rolled spindle operating threads.
- Stainless steel construction as standard.
- PTFE packing standard, optional graphite.
- Alternative tip and materials of construction available.
- Self centering non rotating spindle tip for bubble tight shut off.
- Colour coded functional identification.
- Back stop spindle for blowout prevention, and minimal atmospheric leakage.
- Low torque operating T bar handle.
- Externally adjustable gland.
- Panel and base mount option.
- Variety of end connections including integral compression one piece bodies.
- Angled versions available.
- Dust cap to prevent ingress of contamination to operating thread.
- Bonnet locking pin fitted as standard.

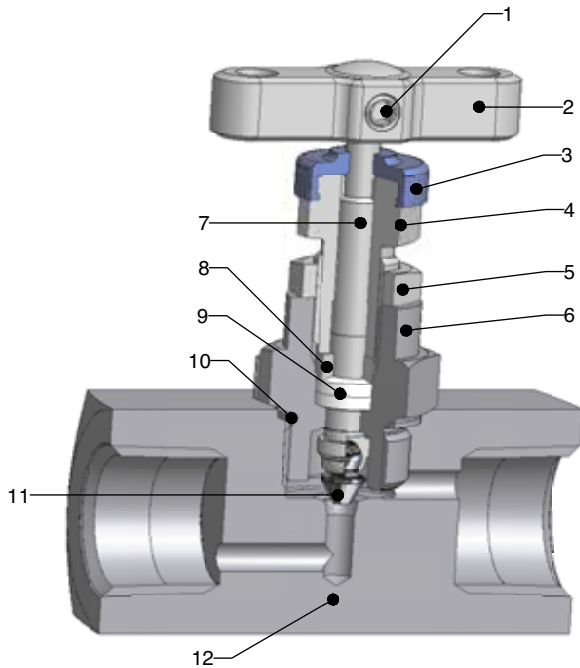

MPI™ Advanced Features

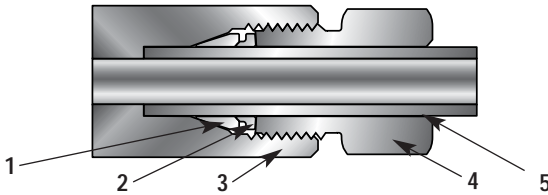

1. Front ferrule with corrosion-resistant Parker SUPARCASE® forms a tight pressure seal between the body and ferrule in a *second* strong mechanical hold on the tube.
2. Rear ferrule with corrosion-resistant Parker SUPARCASE® provides a strong mechanical hold on the tube.
3. Longer thread area for improved resistance to pressure and load on the ferrules.
4. Molybdenum disulfide-coated inverted nut helps prevent galling, provides easier assembly, and permits multiple remakes.
5. Long tube-support area improves resistance to vibration and line loads.

Standard product specification: metal/metal seated, PTFE packed, stainless steel, T bar operation, globe pattern, 10,000 psig (689 barg).

Standard range part numbers

Part no.	Inlet		Outlet		Dimension		
	Female	Female	A mm (inch)	B mm (inch)	C mm (inch)		
HNV*4FFHP	1/4 NPT	1/4 NPT	60.5 (2.38")	31.8 (1.25")	82.6 (3.25")		
HNV*8FFHP	1/2 NPT	1/2 NPT	69.9 (2.75")	31.8 (1.25")	82.6 (3.25")		
	MPI™	MPI™					
HNV*4MPI	1/4	1/4	101.6 (4.00")	31.8 (1.25")	82.6 (3.25")		
HNV*6MPI	3/8	3/8	113.6 (4.48")	31.8 (1.25")	82.6 (3.25")		

*Insert material code

For MPI™ compression ended valve pressure ratings consult tube catalogue CAT 4234 for wall thickness and assembly instructions.

MPI™ only available in stainless steel.

Dimension "C" in open position.

Designed to meet pressure/temperature ratings of ANSI Class 4500 where applicable.

For a full list of options and suffix's, [see page 18](#). For a full list of materials and specifications, [see page 19](#).

Part description

Item	Description
1	Locked grub screw
2	T bar handle assembly
3	Dust cap/function label
4	Gland adjuster
5	Gland locknut
6	Valve bonnet
7	Anti blowout spindle
8	Thrust bush
9	Gland packing (2)
10	Sealing washer
11	Self centering spindle tip
12	Body

Pressure vs temperature

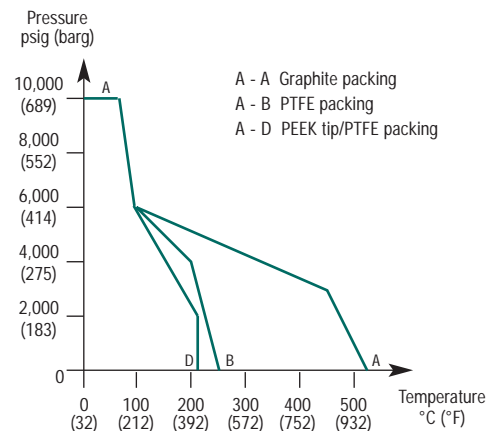

⚠ When selecting products for specific applications users should [refer to our notice at the bottom of page 3](#).

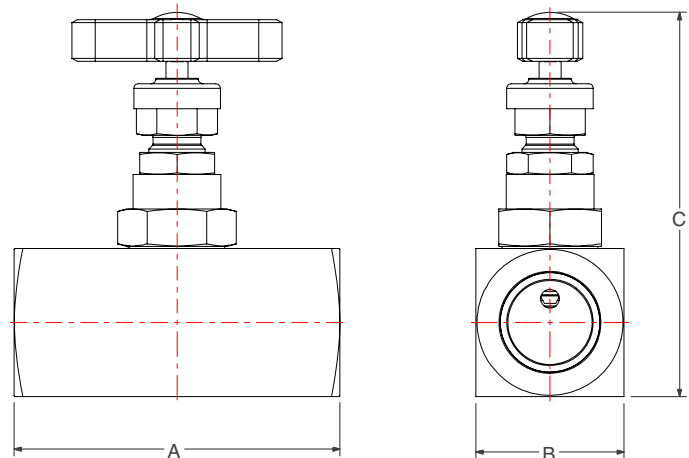

H Series rising plug valves (HRPV series)*

Purpose

These unique, high quality, high performance, low torque rising plug soft-seated valves have been specifically designed to perform with fluids containing high levels of contamination frequently found in oil and gas processing facilities. With a straight through flow pattern and giving 100% repeatable bubble tight shut off, the valves as standard will perform up to 10,000 psig (689 barg) with low spindle operating torques. A variety of end connections are offered for all types of installation. NACE compliance and is also available along with an extensive list of materials of construction.



Specification

- Standard Orifice size 1/4" (6.4mm)
- Cv = 1.8.
- Maximum standard pressure up to 10,000 psig (689 barg).
- Temperature rating Acetal Seat max 93C (200F).
- Port sizes up to 1/2" pipe thread as standard.

Features

- Rolled spindle operating threads.
- 316 Stainless steel construction as standard.
- PTFE packing standard, optional graphite.
- Acetal Seat standard, optional PEEK.
- Alternative body materials available.
- Straight through flow path.
- Standard multi port gauge style available.
- Bi-directional flow.
- Replaceable soft seat.
- Colour coded functional identification.
- Backstop spindle for blowout prevention and minimal atmospheric leakage.
- Low torque operating T bar handle.
- Externally adjustable gland.
- Dust cap to prevent ingress of contamination to operating thread.
- Bonnet locking pin fitted as standard.
- Patent(s) pending.

* Patent(s) pending

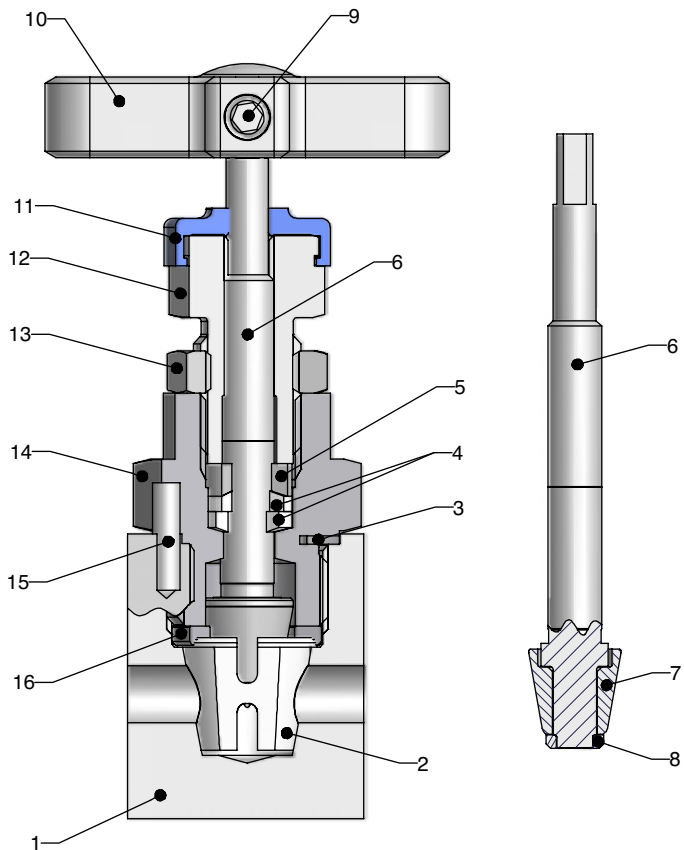

Part description

Item	Description
1	Body
2	Seat
3	Joint seal
4	Packing
5	Thrust bush
6	Stem
7	Tip
8	Stem cap
9	Grub screw
10	Handle
11	Dust cap
12	Gland Adjuster
13	Lock nut
14	Bonnet
15	Pin
16	Seat retainer

Pressure vs temperature

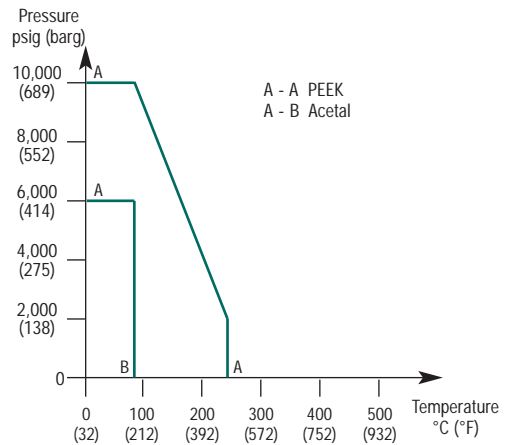

Standard product specification: supplied in 316 stainless steel with Acetal soft seat, PTFE packed, T bar operation, 10,000 psig (689 barg) maximum pressure rating, 93C maximum temperature rating.

Standard range part numbers

Part no.	Connections		Dimension		
	Female	Female	A mm (inch)	B mm (inch)	C mm (inch)
HRPV4S4FF	1/4 NPT	1/4 NPT	60.5 (2.38")	31.8 (1.25")	88.0 (3.46")
HRPV484FF	1/2 NPT	1/2 NPT	69.8 (2.75")	31.8 (1.25")	88.0 (3.46")
	Male	Female			
HRPV4S8M8F	1/2 NPT	1/2 NPT	72.9 (2.87")	31.8 (1.25")	88.0 (3.46")
HRPVG4S8M8F	1/2 NPT	1/2 NPT x 3	96.5 (3.80")	31.8 (1.25")	88.0 (3.46")

⚠ When selecting products for specific applications users should refer to our notice at the bottom of page 3.

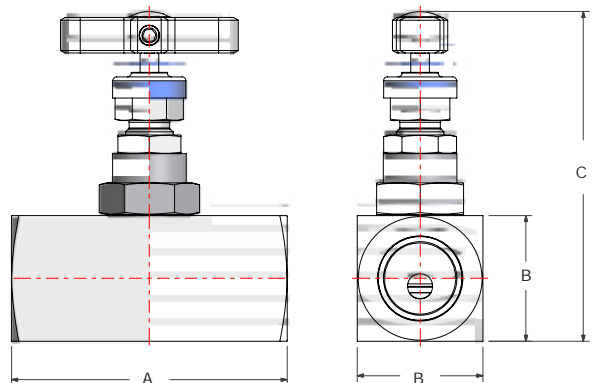

For a full list of options and suffix's, see page 18. For a full list of materials and specifications, see page 19.

Multi-port gauge valves (HGV series)

Purpose

Parker's Multi-port gauge valves are purpose designed valves for operation up to 6,000 psig (414 barg) and 10,000 psig (689 barg). Complete with standard PTFE gland packing and self centering non rotational tip gives the user assurance of bubble tight seat shut off. For gaseous application soft tipped optional seating is available. A wide variety of connector ends are offered for all types of installations. NACE compliance and oxygen clean are also available along with an extensive list of materials. Each valve has 3 female outlets giving the user optimum selection for instrument positioning and location.



Plug

Specification

- Standard seat diameter 4mm (0.16").
- Cv: 0.35 standard.
- Maximum standard pressure up to 6,000 psig (414 barg).
- Maximum optional (HP) up to 10,000 psig (689 barg).
- Temperature rating -54C to +538C (-65F to +1000F).
- Port sizes up to 3/4" pipe thread as standard.

Features

- Rolled spindle operating threads.
- Stainless steel construction as standard.
- PTFE packing standard, optional graphite.
- Alternative tip and materials of construction available.
- Self centering non rotating spindle tip for bubble tight shut off.
- Colour coded functional identification.
- Back stop spindle for blowout prevention and minimal atmospheric leakage.
- Low torque operating T bar handle.
- Externally adjustable gland.
- Base mount option.
- Variety of end connections including integral compression one piece bodies.
- Dust cap to prevent ingress of contamination to operating thread.
- Bonnet locking pin fitted as standard.

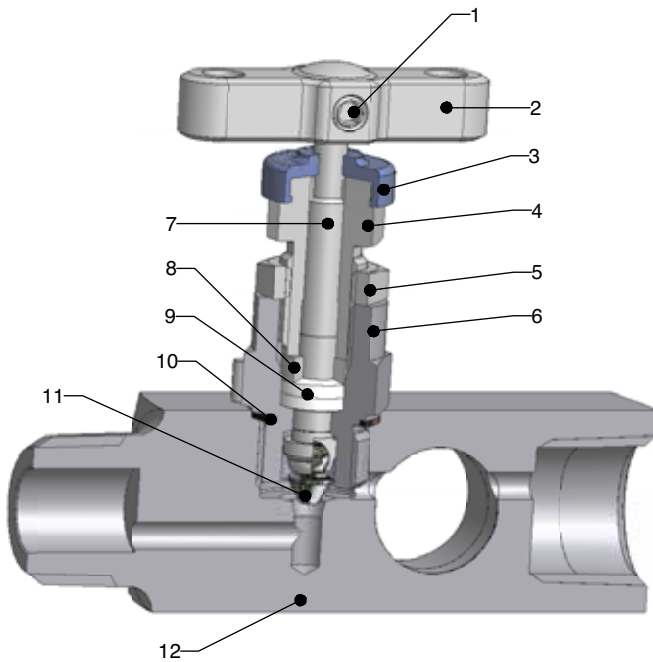

Part description

Item	Description
1	Locked grub screw
2	T bar handle assembly
3	Dust cap/function label
4	Gland adjuster
5	Gland locknut
6	Valve bonnet
7	Anti blowout spindle
8	Thrust bush
9	Gland packing (2)
10	Sealing washer
11	Self centering spindle tip
12	Body

Pressure vs temperature

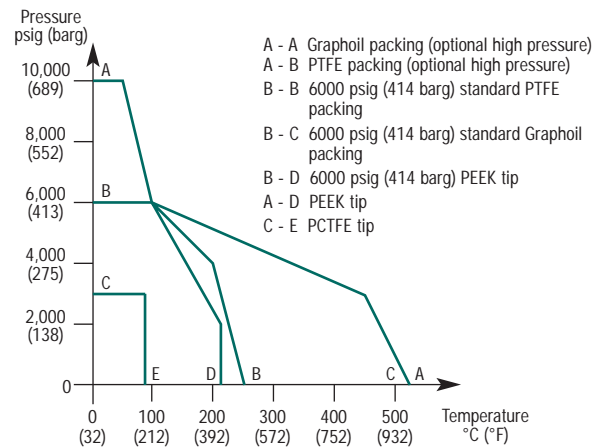

Standard product specification: metal/metal seated, PTFE packed, stainless steel, T bar operation, globe pattern, 6000 psig (414 barg). For complete supply of bleed valve and plug with the valve, add suffix's (see page 18).

Standard range part numbers

Part no.	Inlet		Outlet		Dimension			Pressure rating
	Male	Female x 3	A mm (inch)	B mm (inch)	C mm (inch)			
HGV*8	1/2 NPT	3 X 1/2" NPT	92.0 (3.62")	28.6 (1.13")	79.4 (3.13")		6,000 psi (414 bar)	
HGV*12	3/4 NPT	3 X 1/2" NPT	95.0 (3.74")	28.6 (1.13")	79.4 (3.13")		6,000 psi (414 bar)	
HGV*8HP	1/2 NPT	3 X 1/2" NPT	92.0 (3.62")	31.8 (1.25")	82.6 (3.25")		10,000 psi (689 bar)	

*Insert material code - select from material matrix on page 19
Dimension "C" in open position.

To order individual bleed valves (captive spindle) & plugs

Part no.	Description	Connection
		Male
HBV*4M	Bleed valve	1/4" NPT
HBV*8M	Bleed valve	1/2" NPT
4PHSS	Hexagon plug	1/4" NPT
8PHSS	Hexagon plug	1/2" NPT
4PHSS	Hollow hexagon plug	1/4" NPT
8PHSS	Hollow hexagon plug	1/2" NPT

Plug part numbers are from IPD's pipe fitting range.

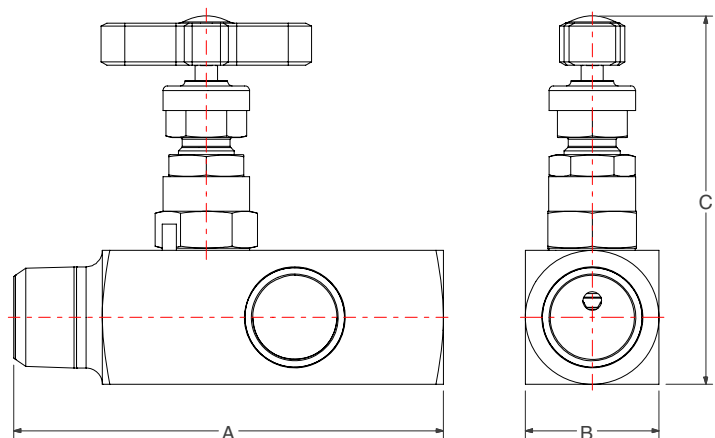

Designed to meet pressure/temperature ratings of ANSI Class 2500/4500 where applicable. For a full list of options and suffix's, see page 18. For a full list of materials and specifications, see page 19.

Single port gauge valves with vent (HVG series)

Purpose

Parker's Single port gauge valves with vent are purpose designed valves for operation with any fluid up to 6,000 psig (414 barg) rating. Valves are provided with a single 1/4" NPT port for the optional fitting of captive bleed/vent valve or blank plug. Complete with standard PTFE gland packing and self centering none rotational tip gives the user assurance of total in service sealing security. For gaseous application soft tipped optional seating is available. A wide variety of end connectors are offered for all types of installations. NACE compliance and oxygen clean are also available along with an extensive list of materials of construction.



Plug

Specification

- Standard seat diameter 4mm (0.16").
- Cv: 0.35 standard.
- Maximum std. pressure up to 6,000 psig (414 barg).
- Temperature rating -54C to +538C (-65F to +1000F).
- Port sizes up to 1/2" pipe thread and 1/2"/12mm tube compression ends.

Features

- Rolled spindle operating threads.
- Stainless steel construction standard.
- PTFE packing standard, optional graphite.
- Alternative tip and materials of construction available.
- Self centering non rotating spindle tip for bubble tight shut off.
- Colour coded functional identification.
- Back stop spindle for blowout prevention and minimal atmospheric leakage.
- Low torque operating T bar handle.
- Externally adjustable gland.
- Base mount option.
- Variety of end connections including integral compression one piece bodies.
- Firesafe option available to API 607 BS 6755 Part 2.
- Dust cap to prevent ingress of contamination to operating thread.
- Bonnet locking pin fitted as standard.

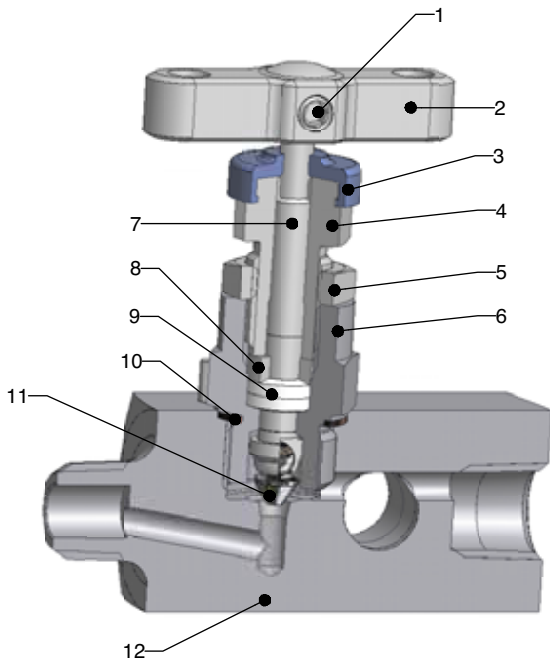

Part description

Item	Description
1	Locked grub screw
2	T bar handle assembly
3	Dust cap/function label
4	Gland adjuster
5	Gland locknut
6	Valve bonnet
7	Anti blowout spindle
8	Thrust bush
9	Gland packing (2)
10	Sealing washer
11	Self centering spindle tip
12	Body

Standard product specification: metal/metal seated, PTFE packed, stainless steel, T bar operation, globe pattern, 1/4" NPT vent/bleed port, 6,000 psig (414 barg).

Add suffix's to obtain bleed valve or plug.

Standard range part numbers

Part no.	Inlet		Outlet		Dimension		
	Female	Female	A mm (inch)	B mm (inch)	C mm (inch)		
HNV*4FFV	1/4 NPT	1/4 NPT	63.5 (2.50")	28.6 (1.13")	79.4 (3.13")		
HNV*6FFV	3/8 NPT	3/8 NPT	67.0 (2.64")	28.6 (1.13")	79.4 (3.13")		
HNV*8FFV	1/2 NPT	1/2 NPT	75.0 (3.00")	28.6 (1.13")	79.4 (3.13")		
	Male		Female				
HNV*4M4FV	1/4 NPT	1/4 NPT	72.5 (2.85")	28.6 (1.13")	79.4 (3.13")		
HNV*8M8FV	1/2 NPT	1/2 NPT	85.8 (3.38")	28.6 (1.13")	79.4 (3.13")		

*Insert material code - select from material matrix on page 19.
Dimension "C" in open position.

To order individual bleed valves (captive spindle) & plugs

Part no.	Description	Connection
		Male
HBV*4M	Bleed valve	1/4" NPT
4PHSS	Hexagon plug	1/4" NPT
4PHSS	Hollow hexagon plug	1/4" NPT

Plug part numbers are from IPD's pipe fitting range.

Designed to meet pressure/temperature ratings of ANSI Class 2500 where applicable.

For a full list of options and suffix's, see page 18. For a full list of materials and specifications, see page 19.

Pressure vs temperature

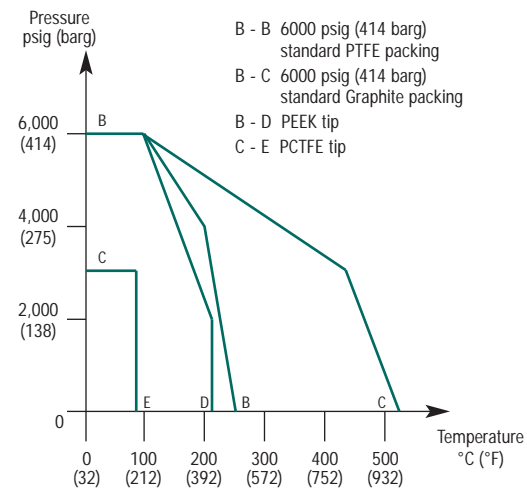

⚠ When selecting products for specific applications users should refer to our notice at the bottom of page 3.

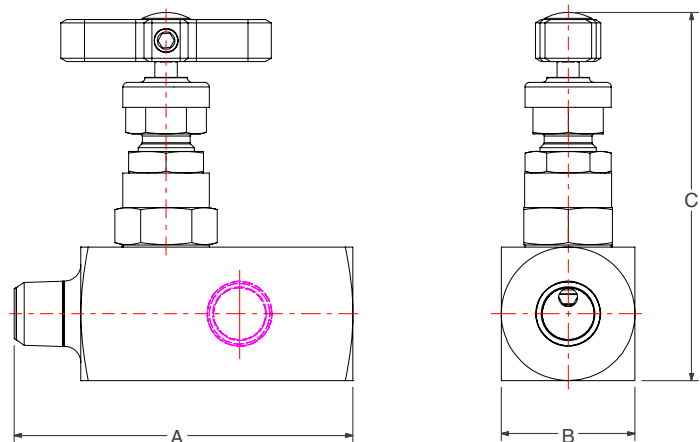

Outside screw and yoke globe pattern needle valves (HYNV series)

Purpose

Outside screw and yoke valves are designed for primary isolating applications operating up to 6,000 psig (414 barg) with optional 10,000 psig (689 barg) rating. The valve is supplied complete with standard graphite gland packing and the self centering non rotational tip gives bubble tight sealing. For gaseous application soft tipped optional seating is available. A wide variety of connector ends are offered for all types of installations including multi-ported root/primary isolate service. NACE compliance and oxygen clean are also available along with an extensive list of materials. Firesafe to BS 6755 Part 2 and API 607 standard with graphite packing.

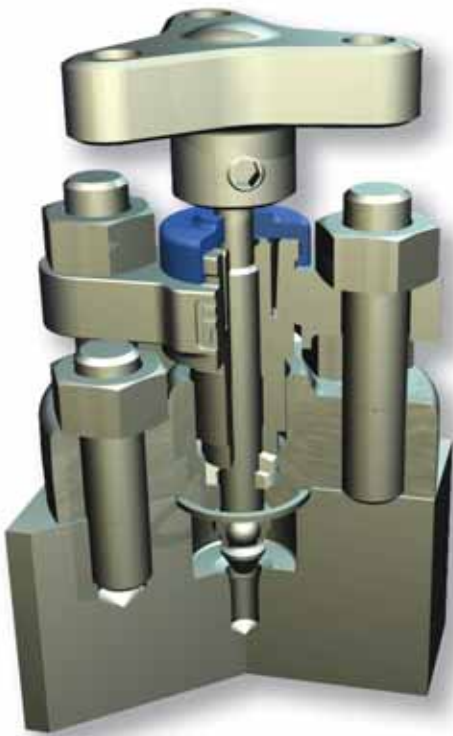

Specification

- Standard seat diameter 4mm (0.16").
- Cv: 0.35 standard.
- Maximum standard pressure up to 6,000 psig (414 barg).
- Maximum optional pressure up to 10,000 psig (689 barg).
- Temperature rating -54C to +538C (-65F to +1000F).
- Port sizes up to 1/2" pipe thread and 1/2"/12mm tube compression ends as standard.

Features

- Rolled spindle operating threads.
- Stainless steel construction standard.
- Graphite packing standard, PTFE optional.
- Alternative tip and materials of construction available.
- Self centering non rotating spindle tip for bubble tight shut off.
- Colour coded functional identification.
- Back stop spindle for blowout prevention.
- Externally adjustable gland independent of spindle thread.
- Base mount option.
- Variety of end connections including integral compression one piece bodies.
- Angled versions available.
- Firesafe design and verified by testing to BS 6755 Part 2 and API 607.

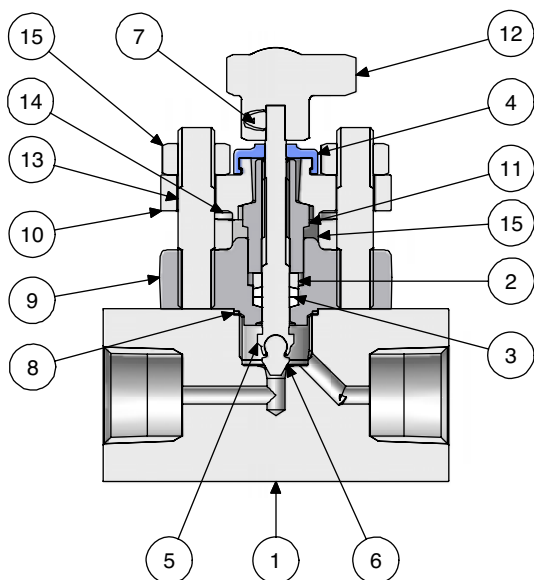

Part description

Item	Description
1	Body
2	Thrust bush
3	Stem packing
4	Dust cap
5	Stem
6	Tip
7	Grub screw
8	Joint seal
9	OS&Y bonnet
10	Gland bridge
11	Gland adjuster
12	Tri-lobal handle
13	Bonnet - gland stud
14	Body - bonnet stud
15	Nuts

Standard product specification: metal/metal seated, Graphite packed, stainless steel, T bar operation, inline pattern, 6000 psig (414 barg).

Standard range part numbers

Part no.	Inlet		Outlet		Dimension		
	Female	Female	A mm (inch)	B mm (inch)	C mm (inch)		
HYNV*4FF	1/4 NPT	1/4 NPT	68.2 (2.685")	38.1 (1.50")	98.9 (3.894")		
HYNV*6FF	3/8 NPT	3/8 NPT	69.2 (2.724")	38.1 (1.50")	98.9 (3.894")		
HYNV*8FF	1/2 NPT	1/2 NPT	76.2 (3.000")	38.1 (1.50")	98.9 (3.894")		
	Male	Female					
HYNV*4M4F	1/4 NPT	1/4 NPT	75.0 (2.953")	38.1 (1.50")	98.9 (3.894")		
HYNV*8M8F	1/2 NPT	1/2 NPT	82.0 (3.268")	38.1 (1.50")	98.9 (3.894")		
HYGV*8	1/2 NPT	3 x 1/2 NPT	108.0 (4.252")	38.1 (1.50")	98.9 (3.894")		
	Socket weld	Socket weld					
HYNV*SW8NB	1/2 pipe	1/2 pipe	76.2 (3.000")	38.1 (1.50")	98.9 (3.894")		
	Butt weld	Butt weld					
HYNV*BW8NB	1/2 pipe	1/2 pipe	89.8 (3.535")	38.1 (1.50")	98.9 (3.894")		
	A-LOK®	A-LOK®					
HYNV*4A	1/4	1/4	87.4 (3.441")	38.1 (1.50")	98.9 (3.894")		
HYNV*8A	1/2	1/2	96.0 (3.780")	38.1 (1.50")	98.9 (3.894")		
HYNV*M6A	6mm	6mm	87.4 (3.441")	38.1 (1.50")	98.9 (3.894")		
HYNV*M12A	12mm	12mm	96.0 (3.780")	38.1 (1.50")	98.9 (3.894")		

*Insert material code - select from material matrix on page 19.

Notes for compression ended valves:-

1. For CPI™ change A to Z.
 2. "A" dimension given for finger tight nuts and ferrules.
 3. Cannot be offered for NACE.
 4. For compression ended valve pressure ratings consult tube ratings table.
- Dimension "C" in open position.

For a full list of options and suffix's, see page 18. For a full list of materials and specifications, see page 19.



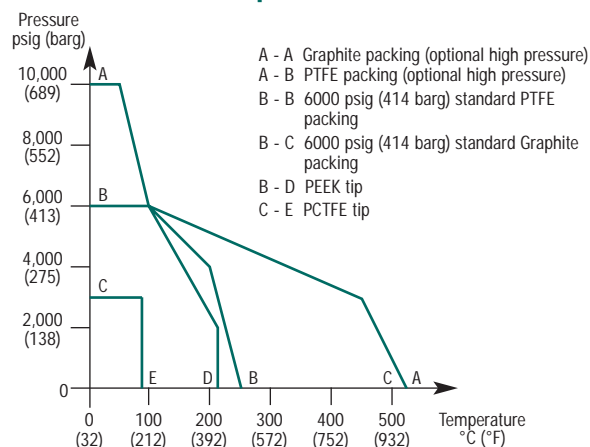

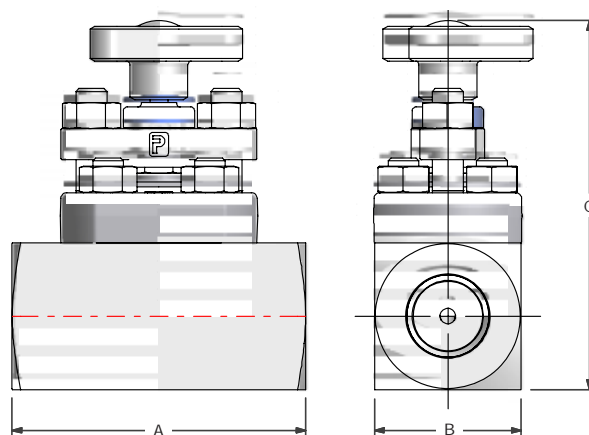

Pressure vs temperature



⚠ When selecting products for specific applications users should refer to our notice at the bottom of page 3.



Instrumentation hand valves

Instrumentation hand valves				Valve types					
Available options									
Suffix adding sequence	Function	Option Detail	Part no. suffix	Needle (HNV series) page 6 & 7	Needle (HNV series) page 8 & 9	Rising plug (HRPV series) page 10 & 11	Multi-port (HGV series) page 12 & 13	Single port (HVG series) page 14 & 15	Outside Screw & yoke (HYNV series) page 16 & 17
1	Gland packing	Graphite	3	✓	✓	✓	✓	✓	
		PTFE	T			✓			✓
		H. F. Fluorocarbon	F			✓			
		EPR	E			✓			
		Nitrile	B			✓			
		Silicone	S			✓			
2	Seating	PCTFE (207 barg/3000 psig)	9	✓			✓	✓	✓
		PEEK	PK	✓	✓	✓	✓	✓	✓
		Stellite tip	ST	✓	✓		✓	✓	✓
		Regulating tip (4mm seat only)	RT	✓	✓				
		6mm seat	6S	✓	✓				
3	Plug/Bleed valve (supplied loose in box)	Blank plug	P			✓	✓		
		Bleed valve	BV			✓	✓		
		Plug & bleed valve	PBV			✓	✓		
4	Connection style	Socket weld (* insert pipe size)	SW*NB	✓	✓		✓	✓	✓
		Male socket weld (*insert pipe size)	MSW*NB	✓	✓		✓	✓	✓
		Butt weld (* insert pipe size) (# insert schedule)	BW*NBSCH#	✓	✓		✓	✓	✓
		Stub pipe extension (insert length in *mm)	SP*MM	✓	✓		✓	✓	✓
		Male inlet extension (* insert length in mm)	EX*MM	✓	✓	✓	✓	✓	✓
		BSPT (* insert pipe size (e.g. 8K = 1/2"))	*K	✓	✓	✓	✓	✓	✓
		BSPP (* insert pipe size (e.g. 4R = 1/4"))	*R	✓	✓	✓	✓	✓	✓
		Flange (specify separately)	FL	✓	✓		✓	✓	✓
5	Connection sizing	See below†		✓	✓	✓	✓	✓	
6	Flow pattern Operating mechanism	Angled	ANG	✓				✓	✓
		Lockable T bar	THL	✓	✓	✓	✓	✓	✓
		Anti tamper T bar	AT	✓	✓		✓	✓	
		Anti tamper + key	ATK	✓	✓		✓	✓	
		Handwheel	HW	✓	✓	✓	✓	✓	✓
		Lockable handwheel	LHW	✓	✓	✓	✓	✓	✓
7	Mounting	Panel mount	PM	✓				✓	
		Base mount	BM	✓	✓	✓	✓	✓	✓
8	Condition	NACE compliant materials**	NC	✓	✓	✓	✓	✓	✓
		Cleaned and lubricated for oxygen use	OXY	✓	✓	✓	✓	✓	✓
		Firesafe	FS	✓			✓	✓	
		Test certificates	TC	✓	✓	✓	✓	✓	✓
		Air testing	PT	✓	✓	✓	✓	✓	✓

†For tube socket or tube butt weld use 1/16 inch denominations and change NB to TB.

†For metric tube size use actual metric (mm) dimensions e.g. SW12MMTB.

Note: Heat code traceable certificates for body and bonnet stud available on application.

**Does not apply for A-lok/CPI ended valves in 316 stainless steel.

Instrumentation hand valves

		Valve types					
Material	*Insert code for selected material in part number	Needle (HNV series) page 6 & 7	Needle (HNV series) page 8 & 9	Rising plug (HRPV series) page 10 & 11	Multi-port (HGV series) page 12 & 13	Single port (HVG series) page 14 & 15	Outside screw & yoke (HYNV series) page 16 & 17
Stainless steel std.	S	✓	✓	*✓	✓	✓	✓
Monel	M	✓	✓	✓	✓	✓	✓
Duplex	D1	✓	✓	✓	✓	✓	✓
Super Duplex	D2	✓	✓	✓	✓	✓	✓
Hasteloy	HC	✓	✓	✓	✓	✓	✓
Carbon Steel	C	✓	✓		✓	✓	✓
6Mo	6MO	✓	✓	✓	✓	✓	✓
Titanium	T	✓	✓	✓	✓	✓	✓
Incoloy 825	825	✓	✓	✓	✓	✓	✓
Inconel 625	625	✓	✓	✓	✓	✓	✓

All non-wetted parts ie those not in contact with the process medium will be supplied in stainless steel for all materials shown above.

* For rising plug valve only in stainless steel use SS as material indicator.

The widest range of precision Instrumentation products



Cat 4190-FP
Flanged products



Cat 4190-PM
Two valve manifolds



Cat 4190-FM
Three and five valve manifolds



Parker Hannifin Corporation
Instrumentation Products Division
1005 A Cleaner Way
Huntsville, AL 35805
USA
Tel: (256) 881-2040
Fax: (256) 881-5072
www.parker.com/ipdus

Parker Hannifin plc
Instrumentation Products Division
Riverside Road
Pottington Business Park
Barnstaple, Devon EX31 1NP
England
Tel: +44 (0)1271 313131
Fax: +44 (0)1271 373636
Email: ipd@parker.com
www.parker.com/ipd