

SHARPE[®] VALVES



SERIES 60
3 PIECE BALL VALVES
CLASS 2500

SHARPE® SERIES 60 HIGH PRESSURE BALL VALVES

STANDARD FEATURES

ASME B16.34 Design

NACE MR0175 Compliance

Blow-out Proof, Heavy-duty Stem

Anti-static Configuration

Live-loaded Stem Seals

Fully Encapsulated Body Seals

Integral Mounting Pad

Locking Handle

Slotted Seat Design

Choice of Seats and Seals

Floating Ball Design

Material Traceability

ADVANTAGES

Full port (Schedule 160) 3-piece bolted body design meets all requirements of ASME B16.34 for Class 2500.

Standard materials of construction have been selected, inspected, and tested to provide compliance with NACE MR0175. Standard bolting is suitable for Non-exposed services.

The internal-entry stem is machined with a heavy shoulder to prevent blowout, and is machined from high-strength 17-4PH stainless steel as a standard material.

Anti-static devices are included at two points on the valve stem to provide continuous ball-to-stem and stem-to-body grounding, to prevent build-up of static charge in the valve, and potential sparking conditions.

Stem seals are live-loaded using Belleville springs to provide consistent sealing forces, reducing or eliminating the need for frequent seal adjustment.

Provides consistent and controlled loading of the body seal for proper compression through the full metal-to-metal contact joint design, eliminating seal extrusion and potential body joint leakage.

Permits easy field conversion from manual operation to power actuation.

All Sharpe Series 60 ball valves supplied with lever handles are designed to permit locking the valve in either the open or closed position.

Relief slots are provided around the perimeter of the seats to allow equalization of pressure in the body cavity with the upstream line when valve is closed, preventing upstream seat extrusion and enhancing downstream sealing performance.

A choice of seat materials is available for the most demanding applications. Stem packing and body seals are die-formed flexible graphite.

Precision engineered and machined solid stainless steel ball with relief hole in the stem slot prevents build-up of cavity pressure while the valve is open.

Body and end piece castings are marked with heat codes providing traceability to the chemical analysis and material test reports performed at the foundry. CMTR's (Certified Material Test Reports) are available upon request.

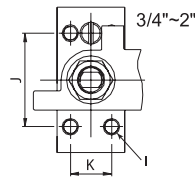
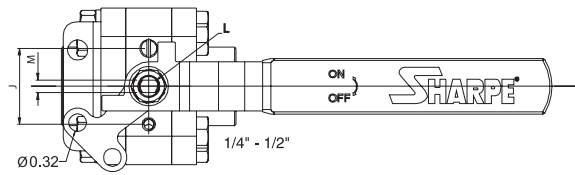
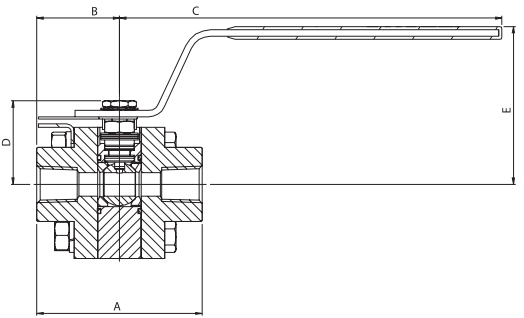
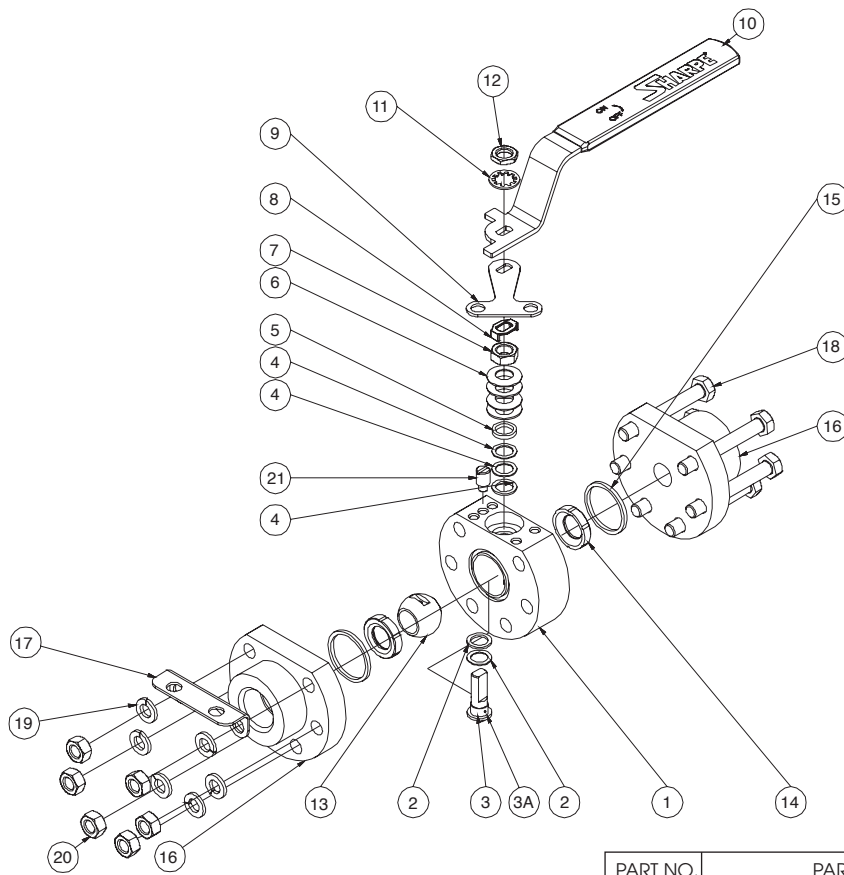

PART NO.	PART	QTY.	MATERIAL
1	Body	1	316 Stainless Steel ASTM A351, CF8M; CS-ASTM A216, WCB
2	Thrust bearing	2	Nylatron; PEEK
3	Stem	1	Stainless Steel 17-4PH
3A	Anti Static Device	1	316 Stainless Steel
4	Stem Packing	3	Nova; Grafoil
5	Gland Packing	1	Stainless Steel 316
6	Belleville Washer	4	Stainless Steel 306
7	Packing Nut	1	Stainless Steel 316
8	Lock Tab	1	Stainless Steel 304
9	Upper Locking Device	1	Stainless Steel 304
10	Handle	1	Stainless Steel 304
11	Lock Washer	1	Stainless Steel 304
12	Handle Nut	1	Stainless Steel 304
13	Ball	1	Stainless Steel 316
14	Seat	2	Delrin; PEEK
15	Body Seal	2	Grafoil; Viton; TFE
16	Pipe Ends	2	Stainless Steel ASTM A351, CF8M; Carbon Steel-ASTM A216, WCB
17	Lower Locking Device	1	Stainless Steel 304
18	Body Bolts	6	ASTM A193, Gr. B8M
19	Body Washers	6	Stainless Steel 304
20	Body Nuts	6	ASTM A194, Gr. 8 or 8M
21	Stop Pin	1	Stainless Steel 316

SIZE	A	B	C	D	E	F	I	J	K	L	M
1/4" - 1/2"	3.07	1.53	7.11	1.55	2.93	0.43	M5*2	1.34	---	3/8" - 24 UNF	0.22
3/4"	3.49	1.74	7.11	1.68	3.06	0.56	M5*5	1.34	0.59	3/8" - 24 UNF	0.22
1"	4.00	2.00	7.69	2.16	2.48	0.81	M5*5	1.34	0.94	7/16" - 20 UNF	0.30
1-1/2"	5.07	2.54	11.53	2.89	3.15	1.25	M6*5	1.34	1.42	9/16" - 18 UNF	0.34
2"	6.14	3.07	11.53	3.08	3.29	1.50	M6*5	1.34	1.57	9/16" - 18 UNF	0.34

Pressure Temperature Ratings - Series 60 Ball Valves

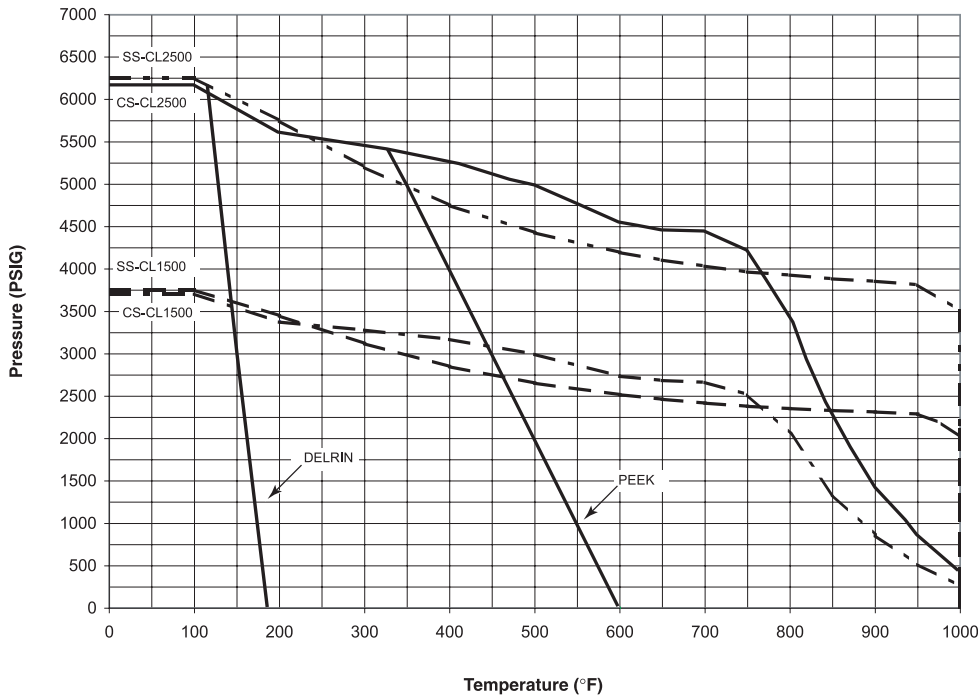

PORT	
1/4"-1/2"	0.44
3/4"	0.56
1"	0.81
1-1/2"	1.25
2"	1.50

	CV	WEIGHT*
1/4"	5	3.55
3/8"	8	3.55
1/2"	23	3.50
3/4"	61	5.30
1"	73	9.90
1-1/2"	82	21.00
2"	150	29.00

* Threaded & SW Valves

**SERIES 60 HIGH PRESSURE VALVES
HOW TO ORDER**

SIZE	SERIES	BODY & ENDS	TRIM	SEATS	SEALS	ENDS	OPTIONS
1/4 3/8 1/2 3/4 1 1-1/2 2	60	4 - Carbon Steel 6 - Stainless Steel	6 - Stainless Steel (17-4PH stem)	D = Delrin P = PEEK	R - TFE G - Grafoil V = Viton	TE - Threaded NPT SW - Socket Weld BW - Buttt Weld Schedule 160 TS - Threaded SAE (J514F) SWE = Extended SW	1 = ANSI CL1500 RF Flange 1J = ANSI CL1500 RTJ Flange 2 = ANSI CL2500 RF Flange 2J = ANSI CL2500 RTJ Flange 3 = SAE J518 Flange E = Extended Stem L = Lockable Extended Stem D = Leak Detection Stem GO = Gear Operator

1-1/2" 60 4 6 D V SW

SHARPE VALVES

A Division of Smith-Cooper International, LLC

Toll-Free 1-877-7SHARPE

(877) 774-2773

Fax: (708) 562-9250

E-Mail: info@sharpevalves.com

www.sharpevalves.com

1260 Garnet Drive

Northlake, Illinois 60164 U.S.A.