

Richter PFA/PTFE Shut-Off and Control Butterfly Valves

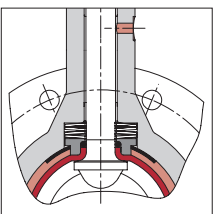

- Body lining PTFE
- Disc/stem unit PFA or stainless steel
- Optional safety stuffing box
- Compliant with German Clean Air Act

Richter wafer-style, lug-style and double-flange butterfly valves

Fields of application

Richter butterfly valves have proved successful in a wide variety of process plants.

- Also suitable for free-flowing, low-abrasive bulk materials in the version with a metallic disc/stem unit.
- Shut-off, throttling and control of corrosive, hazardous and pure liquids, gases and vapours.
- FDA-compliant, wetted materials for in food processing, pharmacy and similar fields.
- The short face to face butterfly valves are advantageous in confined spaces – e.g. under vessels.
- Butterfly valves are economical valves: easy to install and dismantle, attractively priced, compact.

Operating range

- -60 to +200 °C (-75 to 400 °F) operating temperature
- 0.1 mbar (0.0015 psi) vacuum up to 10 bar (145 psi) operating pressure

Product features

- Soft-sealing and gas-tight, both with lined and metallic disc/stem units
- Leak-tight against the atmosphere in acc. with the German Clean Air Act (TA-Luft)
- DN 50-300 (2 -12") optional with safety stuffing box
- Leakage rate in the seat to DIN EN 12266, leakage rate A (formerly DIN 3230 T3): gas-tight, 0 bubbles
- Almost equal-percentage characteristics
- Short face-to-face: ISO 5752 series 20, API 609 Table 1, MSS SP-67 Table 3
- Flanges (with lug-style and double-flange bodies) for connection ISO 7005-2 PN10, ASME (ANSI) B16.5 Class 150, JIS R 2210-10K
- Wetted surfaces anti-adhesive thanks to PFA/PTFE
- Identification of the valves to DIN EN 19, ASME (ANSI) B16.34
- Actuation:
 - hand-lever, lockable
 - worm gear with handwheel
 - pneumatic/electric actuators
 - valves with centering ISO 5211

Type codes, wetted materials

	manual actuation	remote actuation
Double-flange body	NK/...	NKP/...
Wafer-style body	NKS/...	NKSP/...
Lug-style body	NKL/...	NKLP/...
Lining PTFE, disc/stem unit PFA		.../F
Lining PTFE/PFA antistatic		.../F-L
Alternative disc/stem unit of stainless steel		.../...-S

Depending on the body version, the butterfly valves can be installed

- as a wafer-style valve („sandwich-type butterfly valve“) with all three body versions or
- as a flange-mounted or dead-end butterfly valve with lug-style and double-flange body.

See page 6 for installation examples.

① One-piece disc/stem unit

Optional

- **lined with pure PFA fluoroplastic**
The combination of a PFA disc/stem unit with a PTFE body provides very low friction values and torques during the opening and closing processes, minimum wear and a long service life.
- Optional antistatic PFA-L or highly permeation-resistant PFA-P.
- Disc/stem core made of highly torsion resistant Duplex stainless steel ASTM A 351 CD-4 MCu (1.4517)

Alternatively

- **made of stainless steel CF8M (1.4408) precision casting**
 - polished sealing surfaces, thus very low friction values
 - polished disc surfaces on request
 - other materials (e.g. Alloy) on request

② Thick-walled PTFE lining of the valve body

- Lining thickness 3-3.5 mm
- High permeation resistance
- Vacuum-proof
- Optionally TFM-PTFE and antistatic PTFE-L

Wide sealing surfaces of the body lining

for reliable sealing even with mating flanges with large radii, e.g. glass-lined components

- ③ **Maintenance-free and self-adjusting top and bottom stem sealing**, therefore reliable even with many switching cycles and fluctuating temperatures
- primary: body lining against disc/stem shoulder lining
 - secondary: O-ring FKM fluoro-caoutchouc, optional FFKM

TÜV-certified compliance with the German Clean Air Act (TA-Luft) also in standard version without safety stuffing box

- ④ **Pressure-bearing shell made of ductile cast iron**
EN-JS 1049 (ASTM A395), PN 10
- absorbs system and pipe forces
 - centers the valve in the pipe.

- ⑤ **Long valve neck** permits optimal heat insulation without the installation of an elevated lever, additional stem extensions on request.

- ⑥ **External corrosion protection**
Epoxy coating, nuts and bolts made of stainless steel.

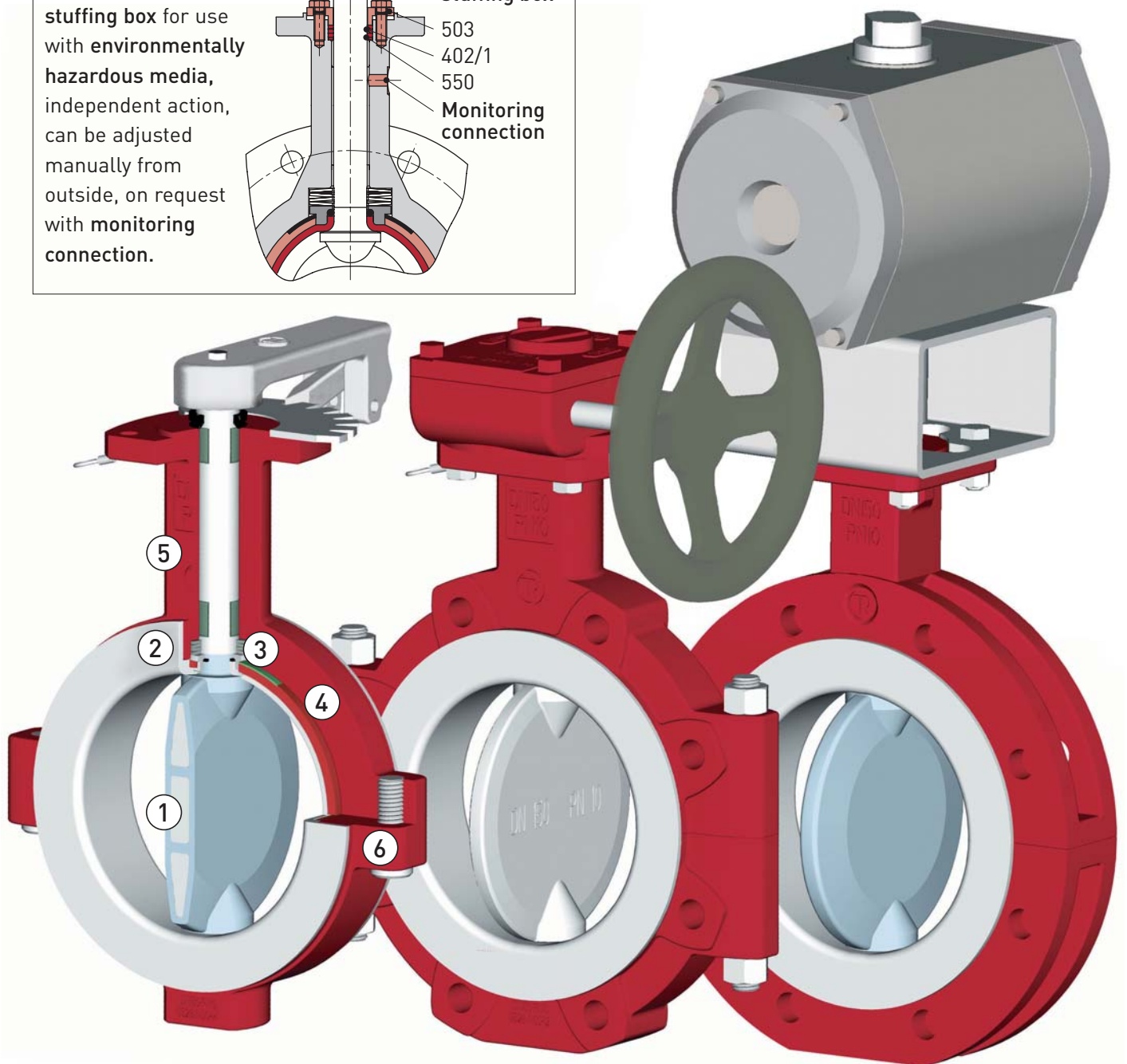
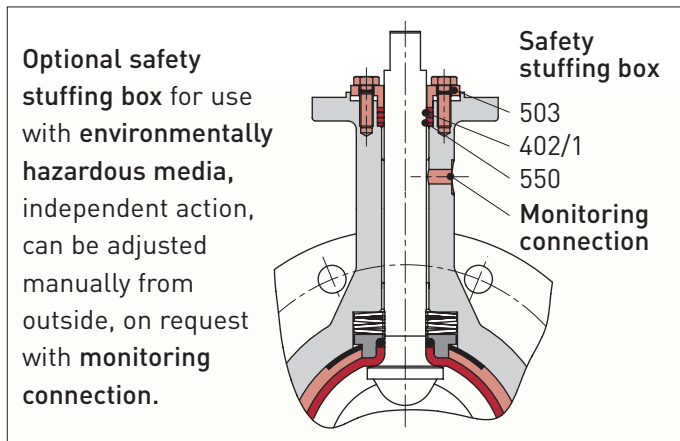

Wafer-style body NKS

Lug-style body NKL

Double-flange body NK

Connecting dimensions, flow rates, torques

Wafer-style body (NKS/NKSP series): DN 50-400 [2-16"]
 Lug-style body (NKL/NKLP series): DN 50-400 [2-16"]
 Double-flange body (NK/NKP series): DN 50-300 [2-12"]
 Other nominal sizes on request.

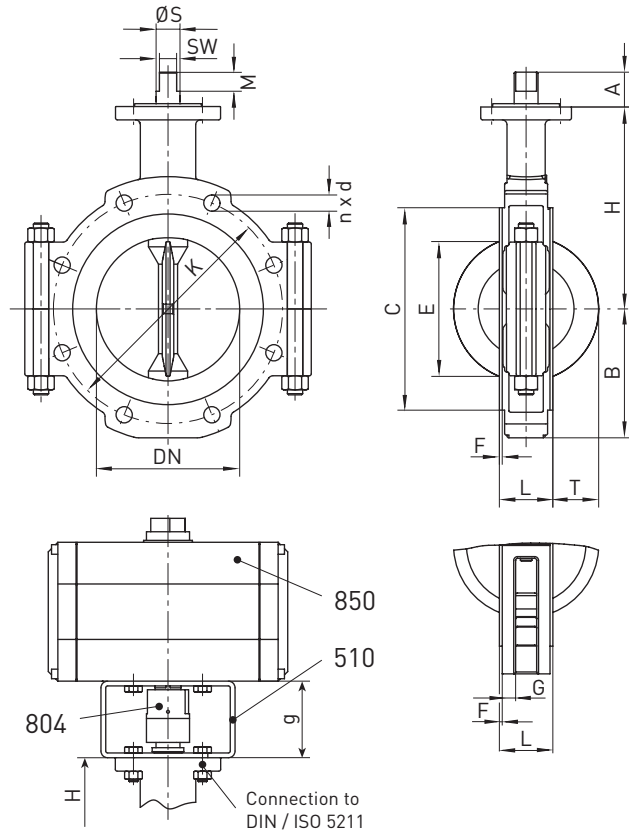

As the distance between the centre of gravity and the disc/stem unit increases, the actuator exerts an increasing bending moment on the stem. Admissible actuator weights on request.

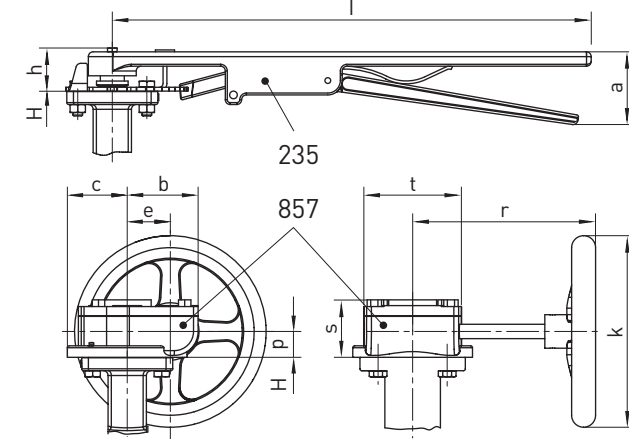

Connection handwheel/worm gear in standard version (top) and in the version „with safety stuffing box“ (bottom).

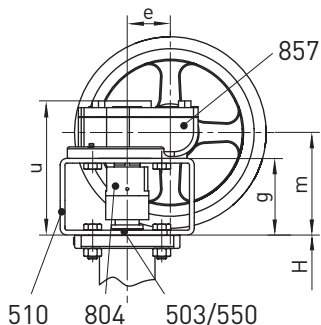

Test medium for torques: water 20 °C (68 °F).
 The torques may be higher depending on the medium, e.g. dry gases, viscous or crystallising liquids.

Installation dimensions (mm) and approx. weights (kg)

DN	50	80	100	150	200	250	300	350	400
inch	2"	3"	4"	6"	8"	10"	12"	14"	16"
L	43	46	52	56	60	68	78	78	102
H	135	160	175	212	232	272	297	335	360
BNKS/NKL	72	89	100	128	165	195	225	258	282
BNK	66	93	106	135	165	195	230	-	-
E	28	67	87	142	193	243	292	343	389
T	4	17.5	24.5	48	71	92	112	137	150
K (ISO)	125	160	180	240	295	350	400	460	515
nxd(ISO) ¹⁾	4 x 19	8 x 19	8 x 19	8 x 23	8 x 23	12 x 23	12 x 23	16 x 23	16 x 28
n ²⁾	4 x M16	8 x M16	8 x M16	8 x M20	8 x M20	12 x M20	12 x M20	16 x M20	16 x M24
K (ASME)	120.5	152.5	190.5	241.5	298.5	362	432	476	540
nxd(ASME) ¹⁾	4 x 19	4 x 19	8 x 19	8 x 22	8 x 22	12 x 26	12 x 26	12 x 29.5	16 x 29.5
n ²⁾	4 x 5/8"	4 x 5/8"	8 x 5/8"	8 x 3/4"	8 x 3/4"	12 x 7/8"	12 x 7/8"	12 x 1"	16 x 1"
C	90	128	150	212	265	315	365	430	480
F	3	3	3	3	3	4	4	4	4
G ³⁾	9	10	13	14	16	16	20	-	-
A	30	30	30	36	36	42	43	50	50
Ø S	14	16	20	25	25	30	32	35	40
SW	10	11	12	18	18	22	22	25	30
M	15	15	16	20	20	25	25	35	35
NKS	3.5	4.5	6	11	15	25	33	47	69
Weight NKL	4.5	7.5	9.5	16	23	35	54	68	97
NK	4	5	7.5	12	19.5	29	47.5	-	-

Flange connecting dimensions to ISO 7005-2 PN 10 and ASME (ANSI) 16.5 Cl. 150

¹⁾ Flange through holes ²⁾ Tapped holes metric or UNC

³⁾ Dimension G only applies to double-flange bodies

Weight (kg) with free shaft end (without lever, bracket etc.)

Connecting dimensions (mm) for remotely actuated version

DN	50	80	100	150	200	250	300	350	400
inch	2"	3"	4"	6"	8"	10"	12"	14"	16"
g	60	60	60	80	80	80	80	100	100
Conn. dim.*	F07	F07	F07	F10	F10	F12	F12	F14	F14

* to DIN/ISO 5211

Hand lever dimensions (mm) and approx. weights (kg)

DN	50	80	100	150	200	250	300	350	400
inch	2"	3"	4"	6"	8"	10"	12"	14"	16"
a	65	65	60	70	70	Worm gear			
l	300	300	300	500	500				
h	40	40	40	48	48				
Weight	0.7	0.7	0.7	3.7	3.7				

Worm gear dimensions (mm) and approx. weights (kg)

DN	50	80	100	150	200	250	300	350	400
inch	2"	3"	4"	6"	8"	10"	12"	14"	16"
b	73	73	73	73	73	105	105	126	126
c	51	51	51	63	63	69	69	100	100
e	45	45	45	45	45	70	70	86	86
g	60	60	60	80	80	80	80	100	100
k	100	150	150	150	150	250	250	250	250
m	87	87	87	107	107	120	120	142	142
p	27	27	27	27	27	40	40	42	42
r	181	181	181	181	181	206	206	226	226
s	62	62	62	62	62	89	89	90	90
t	102	102	102	125	125	130	130	200	200
u	122	122	122	142	142	169	169	190	190
Weight	4	4	4	4.5	4.5	9.5	9.5	15	15

Torques (Nm)

DN	50	80	100	150	200	250	300	350	400
inch	2"	3"	4"	6"	8"	10"	12"	14"	16"
Md	20	46	63	128	185	287	410	550	650
Md _{adm}	100	180	360	725	775	1435	1775	3000	3500

Md_{adm} = max. admissible torque (Nm) with the disc/stem unit blocked.

Flow rates and z-values

DN	k _v -values (m ³ /h)								
	50	80	100	150	200	250	300	350	400
20°	1	5	11	37	62	85	159	230	295
30°	6	22	27	84	170	285	421	610	780
40°	13	47	52	164	354	512	835	1210	1550
50°	24	82	93	276	532	882	1378	2000	2560
60°	41	126	155	431	912	1451	2282	3300	4240
70°	67	197	247	702	1371	2256	3633	5270	6750
80°	104	264	412	1126	2212	3692	5735	8320	10650
90°	120	282	456	1254	2503	4083	6512	9450	12100

Conversion to Cv = k_v x 1.165 [US gpm] = k_v x 0.971 [IMPgpm]

z-values at 75 % flow									
	0.32	0.3	0.29	0.26	0.23	0.19	0.16	0.14	0.12

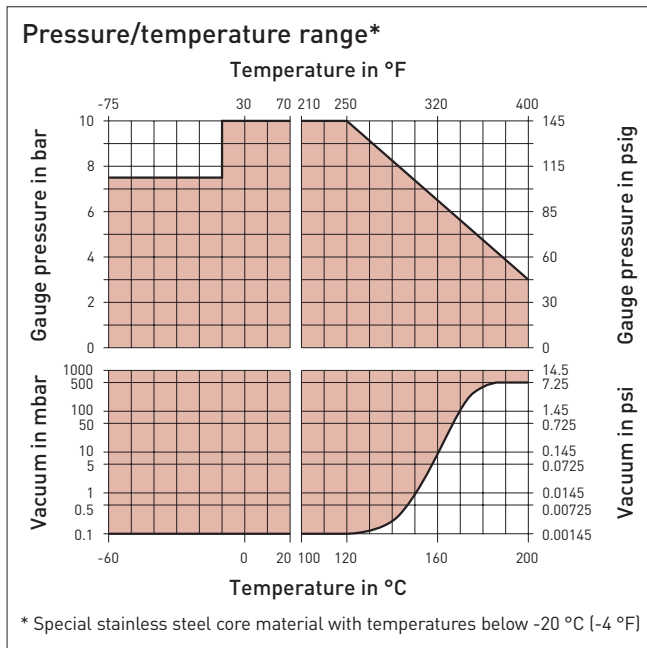

Option:
manual actuation with limit switch
 Inductive or mechanical, connection in acc. with VDI/VDE 3845, alternatively freely mounted sensors

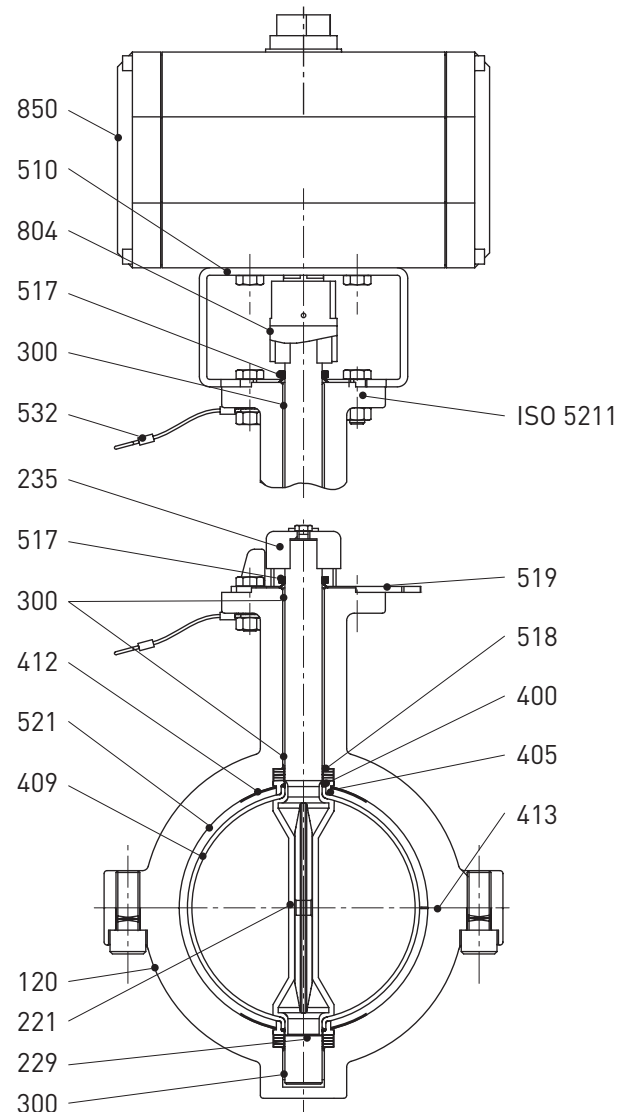

Components and materials

Item	Designation	Standard design	Special design
120	Shell	Ductile cast iron EN-JS 1049 (ASTM A395)	
221	Disc/stem unit, one-piece	Disc/stem core Duplex stainless steel ASTM A351 CD-4 MCu (1.4517), lining PFA	Core stainless steel 1.4408 with temp. < -20 °C/-4 °F, lining PFA-L antistatic, PFA-P highly permeation-resistant
229	Guide pin (DN ≤ 150/6")	Stainless steel	
235	Hand lever	Stainless steel CF8 (1.4308)	
300	Plain bearing	PTFE-lined (triple bearing)	
400	O-ring	FKM (Viton® or equivalent), top and bottom	FFKM (Kalrez® or equivalent)
402/1	Packing rings (see page 3)		PTFE (only with safety stuffing box)
405	Thrust rings	Stainless steel (top and bottom)	
409	Body lining	PTFE	TFM-PTFE, PTFE antistatic
412	Pressure gasket	Aramide	
413	Sealing foils		PTFE (only with safety stuffing box)
503	Packing gland follower (see page 3)		Stainless steel (only with safety stuffing box)
510	Bracket	Connection to DIN EN ISO 5211 and Namur	Special design on request
517	Scraper ring	Fluororubber – no need if safety stuffing box installed	
518	Cup spring assembly	Stainless steel (top and bottom)	
519	Throttling plate with 15° scaling	Stainless steel	
521	Flexible insert	Silicone	FKM (Viton® or equivalent)
532	Grounding cable	Stainless steel	
550	Safety stuffing box, disc (see page 3)		PTFE, stainless steel
	Monitoring connection (see page 3)		Only in conn. with safety stuffing box
804	Coupling	Stainless steel	Special design on request
850	Actuator	Pneumatic quarter-turn actuators e.g. Richter RA, bar, Norbro, El-o-matic, AMG, AirTorque etc.	Pneumatic or electric actuators of various makes
857	Worm gear with handwheel (not illustrated, see page 4)	Body EN-GJL 25 (GG-25) with epoxy coating	Body ductile cast iron, aluminium stem with O-ring sealing, stem and bolts stainless steel
	Stem extension, not illustrated		Design on request
	Screws, nuts, washers	Stainless steel	Other materials, e.g. A193 Gr. B7M

Installation examples

Depending on the body version, the Richter butterfly valves can be installed

- as a wafer-style butterfly valve („sandwich-type butterfly valve“) with all three body versions or
- as a flange-mounted or dead-end butterfly valve with lug-style and double-flange body.

See page 4 for flange holes and threads for connection to ISO, ASME (ANSI) and JIS.

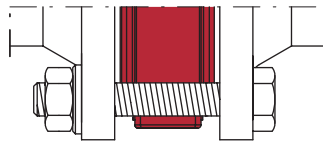

Wafer-style body

The flangeless butterfly valve is secured between two flanges by pipe bolts.

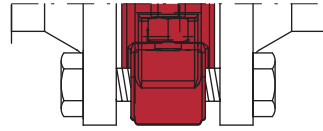

Lug-style body

Lugged options

- Tapped holes: The butterfly valve is installed as a dead-end or flange-mounted valve. The pipe side to be dismantled can be removed without any axial displacement, the butterfly valve acts as a dead-end valve.
- Through holes: The butterfly valve is centered in the holes by pipe through bolts and secured by the pipe flanges.

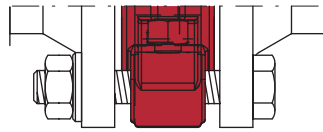

Double-flange body

Flanged options

- Through holes: The butterfly valve is centered as a wafer-style valve by means of pipe through bolts in the holes. Alternatively, it can be installed as a dead-end valve with a nut inserted between the valve flanges.
- Tapped holes: The valve is installed as a dead-end or flange-mounted valve. The pipe side to be dismantled can be removed without any axial displacement.
- Glass connection: On the glass side, tapped holes or through holes with collar bush.

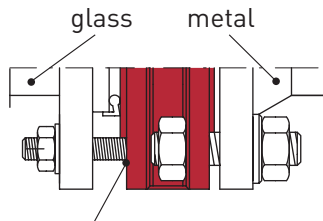

On request collar bush instead of tapped hole.

Kalrez®, Viton®: Trademark of Du Pont
Richter: Trademark of Richter Chemie-Technik GmbH

Presented by:

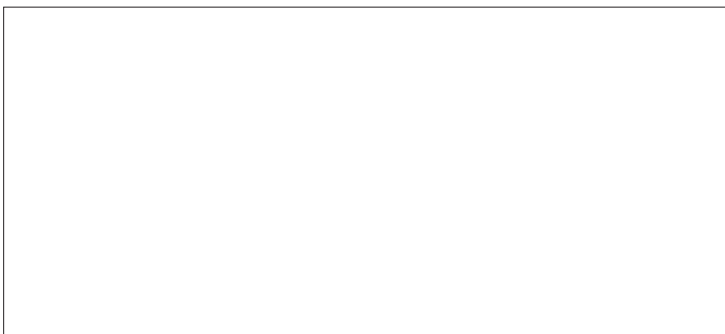

Richter Chemie-Technik GmbH
Otto-Schott-Str. 2
D-47906 Kempen, Germany
Tel. +49 (0) 21 52/146-0
Fax +49 (0) 21 52/146-190
richter-info@richter-ct.com
www.richter-ct.com