

Pneumatic Control Valves Type 3244-1 and Type 3244-7 Three-way Valve Type 3244

DIN and ANSI versions

Application

Mixing or flow-diverting valves for use in process engineering and industrial applications

Nominal size DN 15 to 150 · ½" to 6"
Nominal pressure PN 10 to 40 · ANSI Class 150 to 300
Temperatures DIN: -196 to 450 °C · -321 to 842 °F
 ANSI: -198 to 427 °C · -325 to 800 °F

Type 3244 Three-way Valve with:

- Type 3271 Pneumatic Actuator (Fig. 1) or
- Type 3277 Pneumatic Actuator (Fig. 2) for integral positioner attachment

Valve body made of:

- Cast iron (DIN version only)
- Cast steel or
- Cast stainless steel

Undivided bonnet

These control valves in modular design can be equipped with various accessories:

Positioners, solenoid valves, limit switches and other accessories according to IEC 60534-6 and NAMUR recommendation (see Information Sheet T 8350 EN for details).

Optional integral positioner attachment with Type 3277 Pneumatic Actuator (see Data Sheet T 8310-1 EN for details).

Versions

Standard version designed for temperatures from -10 °C to +220 °C (15 °F to 430 °F)

- **Type 3244-1** (Fig. 1) · Type 3244 Three-way Valve with Type 3271 Pneumatic Actuator (see Data Sheets T 8310-1/-2 EN)
- **Type 3244-7** (Fig. 2) · Type 3244 Three-way Valve with Type 3277 Pneumatic Actuator for integral positioner attachment (see Data Sheet T 8310-1 for details)

Additional versions with:

- **Bellows seal or insulating section** · See Technical data
- **Adjustable packing** · Details on request
- **Heating jacket**
- **Additional handwheel** · See Data Sheet T 8310-1 EN

Also available:

- **Type 3244-2 Electric Control Valve** · Details on request
- **Type 3244-3 Manually Operated Valve** with Type 3273 Hand-operated Actuator · See Data Sheet T 8312 EN for details



Fig. 1 · Type 3244-1 Pneumatic Control Valve
Type 3271 Actuator



Fig. 2 · Type 3244-7 Pneumatic Control Valve
with Type 3277 Actuator

Principle of operation (Figs. 3 and 4)

Depending on the valve version, the three-way valve can be used for either mixing or flow-diverting service.

In mixing valves, the process media to be mixed enter at valve ports A and B. The combined stream flows off at port AB (see Fig. 3). The flow rate from port A or B to port AB depends on the cross-sectional area of flow between the seats and the valve plugs.

In flow-diverting valves, in contrast, the process medium enters at port AB and the partial streams flow off at ports A and B (see Fig. 4).

Note: The design of the mixing and flow-diverting valves in sizes DN 15 to 25 (1/2" to 1") is identical.

Fail-safe position

Depending on the arrangement of the compression springs in the actuator (see Data Sheet T 8310-1 EN or T 8310-2 EN for details), the valve has two fail-safe positions which become effective upon supply air failure:

Actuator stem extends (FA)

Whenever the air supply fails, either port B (mixing valve) or port A (flow-diverting valve) is closed.

Actuator stem retracts (FE)

Whenever the air supply fails, either port A (mixing valve) or port B (flow-diverting valve) is closed.

Notes on the differential pressures in Tables 3a to 4b

- Values specified in the gray-shaded columns correspond to the standard bench range
- Differential pressures specified in the white columns apply to maximum pretensioned springs
- Differential pressures in parentheses refer to the values in parentheses in the bench range row
- The tables apply to both fail-safe positions
- The springs in actuators with fail-safe action "Actuator stem retracts" cannot be pretensioned.

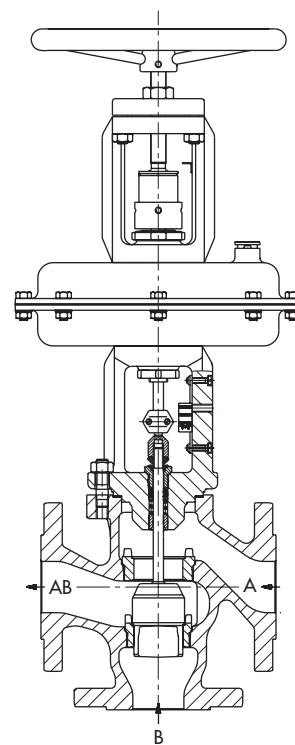

Fig. 3 · Type 3244-1 Pneumatic Control Valve with Type 3244 Three-way Valve (plug arrangement for mixing service (DN 15 to 25 for flow-diverting service as well) and Type 3271 Actuator with additional handwheel

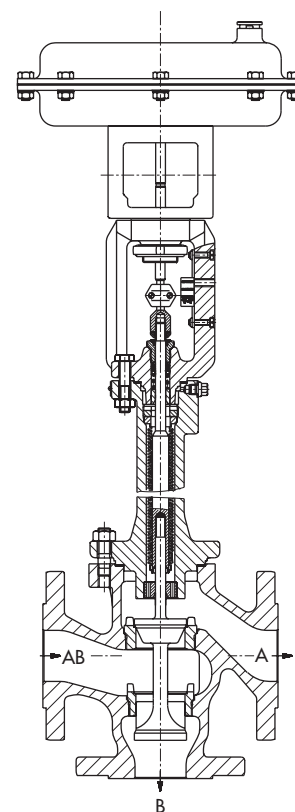

Fig. 4 · Type 3244-7 Pneumatic Control Valve with Type 3244 Three-way Valve, DN 32 to 150 (plug arrangement for flow-diverting service), additional bellows seal and Type 3277 Actuator

Table 1 · Technical data

Version	DIN			ANSI		
Nominal size	DN	15 ... 150			½" ... 6"	
Material	Cast iron EN-JL1040	Cast steel 1.0619	Cast stainless steel 1.4581	Carbon steel A 216 WCC	Stainless carbon steel A 351 CF8M	
Nominal pressure	PN 10, 16, 25, 40 acc. to DIN 2401			ANSI Class 150 or 300		
End connections	All flange designs acc. to DIN ¹⁾			RF ²⁾		
Seat-plug sealing	Metal			Metal		
Characteristic	Linear			Linear		
Rangeability	50 : 1 for DN 15 ... 50 30 : 1 for DN 65 ... 150			50 : 1 for ½" ... 2" 30 : 1 for 2½" ... 6"		
Temperature ranges in °C and °F · Permissible operating pressures according to pressure-temperature diagram						
Body without insulating section	-10 ... 220 °C			-10 ... 220 °C (15 ... 430 °F)		
Body with	Short insulating section ³⁾	-10 ... 300 °C	-10 ... 400 °C ⁴⁾	-10 ... 450 °C ⁴⁾	-29 ... 427 °C (-20 ... 800 °F)	-50 ... 427 °C (-58 ... 800 °F)
	Short bellows seal	-10 ... 300 °C	-10 ... 400 °C ⁴⁾	-10 ... 450 °C ⁴⁾	-29 ... 400 °C (-20 ... 750 °F)	-50 ... 400 °C (-58 ... 750 °F)
Valve plug	Metal sealing	-196 ... 450 °C			-198 ... 427 °C (-325 ... 800 °F)	
Leakage class (DIN EN 1349)	0.05 % K _{Vs}			0.05 % K _{Vs}		

¹⁾ Connections for DN 15 only acc. to DIN 2532, 2533, 2543 to 2545 ²⁾ Other versions on request

³⁾ Long insulating section on request

⁴⁾ Version for lower temperatures on request

Table 2 · Materials

Standard version	DIN			ASTM	
Valve body	Cast iron EN-JL1040	Cast steel 1.0619	Cast stainless steel 1.4581	Carbon steel A 216 WCC	Stainless carbon steel A 351 CF8M
Valve bonnet	1.0460		1.4571	A 105	A 182 F 316
Seat ¹⁾	1.4006		1.4571	1.4006	1.4571
Plug ¹⁾	1.4008		1.4571	1.4006	1.4571
Guide bushings	1.4104		1.4571	1.4104	1.4571
Packing ²⁾	V-ring packing, PTFE with carbon · Spring 1.4310				
Body gaskets	Metal/graphite			Metal/graphite	
Insulating section	1.0460		1.4571	A 105	A 182 F 316
Metal bellows seal					
Intermediate piece	1.0460		1.4571	A 105	A 182 F 316
Metal bellows	1.4571			1.4571	
Heating jacket	On request			On request	

¹⁾ All seats and plugs available with Stellite facings

²⁾ Other packings on request

**Table 3a · K_{Vs} coefficients and permissible differential pressures
Type 3244 Mixing Valve · DIN version · Pressures in bar**

Bench range in bar for actuator with effective area					120 cm ²	–	–	0.4...2.0 (1.2...2.0)	–	–	–	1.4...2.3	2.1...3.3
					240 cm ²	0.2...1.0	–		–	–	–	–	
					350 cm ²		0.4...1.2		0.8...2.4	0.6...3.0 (1.8...3.0)	1.2...3.6	1.4...2.3 (1.85...2.3)	2.1...3.3 (2.7...3.3)
					700 cm ²								
Required supply pressure in bar					1.2	1.6	2.4 (3.2)	3.2	3.6 (4.8)	4.8	3.7 (4.2)	5.4 (6.0)	
DN	K _{Vs} Mixing valve	Seat Ø in mm	Rated travel in mm	Actuator cm ²	Δp when p ₂ = 0 bar								
15	2 · 4	24	15	120	–	–	5.2	–	–	–	29.3	40	
				20	2 · 4 · 6.3	240	5.2	–	14.8	–	24.9	–	–
25	2 · 4 6.3 · 10			350	9.6	23.7	23.7	40	37.8	40	40	40	
				700	23.7	–	–	–	–	–	–	–	
32 to 50	6.3 · 10 · 16	31	15	120	–	–	–	–	–	–	17	27.1	
				350	5.2	13.6	13.6	30.5	22.0	40	40	40	
				700	13.6	–	–	–	–	–	–	–	
40 and 50	25	38	15	120	–	–	–	–	–	–	10.9	17.7	
				350	3.1	8.7	8.7	19.9	14.3	31.1	36.7	40	
				700	8.7	–	–	–	–	–	–	–	
50	40	48	15	120	–	–	–	–	–	–	6.5	10.7	
				350	1.6	5.1	5.1	12.1	8.6	19.2	22.7	35	
				700	5.1	–	(40)	–	(40)	–	–	–	
65 80	25 and 40	48	15	350	1.6	5.1	5.1	12.1	8.6	19.2	22.7	35	
				700	5.1	–	(40)	–	(40)	–	–	–	
65 80	60	63	15	350	–	2.7	2.7	6.7	4.7	10.8	12.9	20	
				700	2.7	–	(23.1)	–	(35.3)	–	(36.3)	(40)	
80	80	75	15	350	–	1.7	1.7	4.6	3.1	7.5	8.9	13.9	
				700	1.7	–	(16.1)	–	(24.7)	–	(25.5)	37.7	
100	100	80	30	700	1.4	3.9	3.9	9.0	6.4	14	16.6	25.4	
	160	100			–	2.3	2.3	5.6	4.0	8.8	10.4	16.1	
125	140	90			–	3.0	3.0	7.0	5.0	11	13	20	
	200	110			–	1.9	1.9	4.5	3.2	7.2	8.6	13.3	
150	200	110			–	1.9	1.9	4.5	3.2	7.2	8.6	13.3	
	300	130			–	1.2	1.2	3.2	2.2	5.1	6.0	9.4	

**Table 3b · Cv coefficients and permissible differential pressures
Type 3244 Mixing Valve · ANSI version · Pressures in psi**

Bench range in psi for actuator with effective area						120 cm ²	–	–	6...30 (18...30)	–	–	–	20...34	30...48	
						240 cm ²	3...15	–		12...35	9...44 (26...44)	–	18...52	–	–
						350 cm ²		6...18				–		–	–
						700 cm ²		–				–		–	–
Required supply pressure in psi						18	23	35 (47)	47	52 (70)	70	54 (61)	78 (87)		
DN		Cv Mixing valve	Seat Ø in (mm)	Rated travel in (mm)	Actuator cm ²	Δp when p ₂ = 0 psi									
in	mm														
½"	15	2.3 · 5	0.94 (24)	0.59 (15)	120	–	–	75	–	–	–	425	580		
	¾"	20			2.3 · 5 · 7.5	240	75	–	215	–	355	–	–	–	–
		1"			25	2.3 · 5 7.5 · 12	350	139	344	344	580	548	580	580	580
700	344		–				–	–	–	–	–	–	–	–	
1½" and 2"	40 and 50	7.5 · 12 · 20	1.22 (31)		120	–	–	–	–	–	–	–	247	393	
					350	75	197	197	442	319	580	580	580	580	
					700	197	–	–	–	–	–	–	–	–	–
	2"	50	47		1.49 (38)	120	–	–	–	–	–	–	–	158	257
						350	45	126	126	289	207	451	532	580	
						700	126	–	–	–	–	–	–	–	–
2½" 3"	65 80	30 and 47	1.89 (48)		120	–	–	–	–	–	–	–	94	155	
					350	23	74	74	175	125	278	329	508		
					700	74	–	(580)	–	(580)	–	–	–	–	
	3"	80	95		2.48 (63)	350	23	74	74	175	125	278	329	508	
						700	74	–	(580)	–	(580)	–	–	–	
				350		–	39	39	97	68	157	187	290		
3"	80	95	2.95 (75)	700	39	–	(335)	–	(512)	–	(526)	(580)			
				350	–	25	25	67	45	109	129	202			
4"	100	120	3.15 (80)	700	700	25	–	(233)	–	(358)	–	(370)	547		
					20	57	57	131	93	203	241	368			
6"	150	230	4.33 (110)	1.18 (30)	700	–	33	33	81	58	128	151	233		
						–	28	28	65	46	104	125	193		
		–	17			17	46	32	74	87	136				
		–	17			17	46	32	74	87	136				

**Table 4a · K_{Vs} coefficients and permissible differential pressures
Type 3244 Flow-diverting Valve · DIN version · Pressures in bar**

Valves in DN 65 to 150: Direction of flow AB ⇒ A with maximum K_{Vs} and
AB ⇒ B with reduced K_{Vs}

Bench range in bar for actuator with effective area					120 cm ²	–	–	0.4...2.0 (1.2...2.0)	–	–	–	1.4...2.3	2.1...3.3
					240 cm ²	0.2...1.0	–		–	–	–	–	
350 cm ²	0.4...1.2	0.8...2.4	0.6...3.0 (1.8...3.0)	1.2...3.6	1.4...2.3 (1.85...2.3)		2.1...3.3 (2.7...3.3)						
700 cm ²													
Required supply pressure in bar					1.2	1.6	2.4 (3.2)	3.2	3.6 (4.8)	4.8	3.7 (4.2)	5.4 (6.0)	
DN	K _{Vs} Diverting valve	Seat ∅ in mm	Rated travel in mm	Actuator cm ²	Δp when p ₂ = 0 bar								
15	2 · 4	24	15	120	–	–	5.2	–	–	–	29.3	40	
20	2 · 4 · 6.3			240	5.2	–	14.8	–	24.5	–	–	–	
25	2 · 4 6.3 · 10			350	9.6	23.7	23.7	40	37.8	40	40	40	
				700	23.7	–	–	–	–	–	–	–	
32 to 50	6.3 · 10 · 16	31		120	–	–	–	–	–	–	17	27.1	
				350	5.2	13.6	13.6	30.5	22.0	40	40	40	
				700	13.6	–	–	–	–	–	–	–	
40 and 50	25	38		120	–	–	–	–	–	–	10.9	17.7	
				350	3.1	8.7	8.7	19.9	14.3	31.1	36.7	40	
				700	8.7	–	–	–	–	–	–	–	
50 to 80	40	48		120	–	–	–	–	–	–	6.5	10.7	
				350	1.6	5.1	5.1	12.1	8.6	19.2	22.7	35	
			700	5.1	–	(40)	–	(40)	–	–	–		
65 80	25 and 40	48	350	1.6	5.1	5.1	12.1	8.6	19.2	22.7	35		
			700	5.1	–	(40)	–	(40)	–	–	–		
65	60/40	63/48	350	–	2.7	2.7	6.7	4.7	10.8	12.9	20		
			700	2.7	–	(23.1)	–	(35.3)	–	(36.3)	(40)		
80	60	63	350	–	2.7	2.7	6.7	4.7	10.8	12.9	20		
			700	2.7	–	(23.1)	–	(35.3)	–	(36.3)	(40)		
80	80/60	75/63	350	–	1.7	1.7	4.6	3.1	7.5	8.9	13.9		
			700	1.7	–	(16.1)	–	(24.7)	–	(25.5)	(37.7)		
100	100	80	30	700	1.4	3.9	3.9	9.0	6.4	14	16.6	25.4	
	160/100	100/80			–	2.3	2.3	5.6	4.0	8.8	10.4	16.1	
125	140	90			–	3.0	3.0	7.0	5.0	11	13	20	
	200/140	110/90			–	1.9	1.9	4.5	3.2	7.2	8.6	13.3	
150	200	110			–	1.9	1.9	4.5	3.2	7.2	8.6	13.3	
	300/200	130/110			–	1.2	1.2	3.2	2.2	5.1	6.0	9.4	

**Table 4b · C_v coefficients and permissible differential pressures
Type 3244 Flow-diverting Valve · ANSI version · Pressures in psi**

Valves in 2½" to 6": Direction of flow AB ⇒ A with maximum C_v and
AB ⇒ B with reduced C_v

					120 cm ²	–	–		–	–	–	20...34	30...48	
Bench range in psi for actuator with effective area					240 cm ²	–	–	6...30 (18...30)	–	9...44 (26...44)	–	–	–	
					350 cm ²	3...15	–		12...35		18...52	20...34 (26...34)	30...48 (39...48)	
					700 cm ²	–	6...18	–		–	–	–		
					Required supply pressure in psi					18	23	35 (47)	47	52 (70)
DN		C _v Diverting valve	Seat Ø in mm	Rated travel in mm	Actuator cm ²	Δp when p ₂ = 0 psi								
in	mm													
½"	15	2.3 · 5	0.94 (24)	0.59 (15)	120	–	–	75	–	–	–	425	580	
¾"	20	2.3 · 5 · 7.5			240	75	–	215	–	355	–	–	–	–
1"	25	2.3 · 5 7.5 · 12			350	139	344	344	580	548	580	580	580	580
					700	344	–	–	–	–	–	–	–	–
1½" and 2"	40 and 50	7.5 · 12 · 20	1.22 (31)		120	–	–	–	–	–	–	–	247	393
					350	75	197	197	442	319	580	580	580	
		30	1.49 (38)		120	–	–	–	–	–	–	–	158	257
					350	45	126	126	289	207	451	532	580	
2" to 3"	50 to 80	47	1.89 (48)		700	126	–	–	–	–	–	–	–	–
					120	–	–	–	–	–	–	–	94	155
					350	23	74	74	175	125	278	329	508	
2½" 3"	65 80	30 and 47	1.89 (48)		700	74	–	(580)	–	(580)	–	–	–	–
				350	23	74	74	175	125	278	329	508		
		70	2.48 (63)	350	–	39	39	97	68	157	187	290		
				700	39	–	(335)	–	(512)	–	(526)	(580)		
3"	80	95/70	2.95/2.48 (75/63)	350	–	25	25	67	45	109	129	202		
				700	25	–	(233)	–	(358)	–	(370)	547		
4"	100	120	3.15 (80)	1.18" (30)	700	20	57	57	131	93	203	241	368	
		190/120	3.93/3.15 (100/80)			–	33	33	81	58	128	151	233	
230	4.33 (110)	–	28			28	65	46	104	125	193			
		350/230	5.12/4.33 (130/110)			–	17	17	46	32	74	87	136	

Table 5 · Dimensions
Table 5a · Type 3244 Valve · DIN version

Valve	DN	15	20	25	32	40	50	65	80	100	125	150
Length L	mm	130	150	160	180	200	230	290	310	350	400	480
H1	mm	235					270			360	375	
H2	mm	70	80	85	100	105	120	130	140	150	200	210

Table 5b · Type 3244 Valve · ANSI version

Valve		in	½	¾	1	1½	2	2½	3	4	6
		mm	15	20	25	40	50	65	80	100	150
Length	Class 150	mm	184	184	184	222	254	276	298	352	451
		in	7.25	7.25	7.25	8.75	10.0	10.87	11.75	13.87	17.75
	Class 300	mm	190	194	197	235	267	292	318	368	473
		in	7.50	7.62	7.75	9.25	10.50	11.50	12.50	14.50	18.62
H1	mm	235					270			360	375
	in	9.25					10.63			14.17	14.76
H2	Class 150	mm	92	92	92	111	127	138	149	176	225.5
		in	3.62	3.62	3.62	4.37	5.0	5.43	5.87	6.93	8.88
	Class 300	mm	95	97	98.5	117.5	133.5	146	159	184	236.5
		in	3.76	3.82	3.88	4.63	5.26	5.75	6.26	7.24	9.31

Table 5c · Type 3271 and Type 3277 Actuators

Effective diaphragm area	cm ²	120	240	350	700
Diaphragm Ø	mm	168	240	280	390
H	mm	69	62	82	138
	in	2.71	2.45	3.23	5.43
H3 (Types 3271 and 3277)	mm	110			190
	in	4.33			7.48
Thread		M30 x 1.5			
a with Type 3271		G ¼ (¼ NPT)			G ¾ (¾ NPT)
a2 with Type 3277		-			G ¾

Table 5d · Version with short or long insulating section or bellows seal

Valve	DN	mm	15	20	25	32	40	50	65	80	100	125	150
		in	½	¾	1	-	1½	2	2½	3	4	-	6
H4 with	Short insulating section or bellows seal	mm	420					455		645	655		
		in	16.54					17.91		25.39	25.79		
	Long insulating section or bellows seal	mm	725					760		895	900		
		in	28.54					29.92		35.24	35.43		

Table 6 · Weights

Table 6a · Type 3244 Valve

Valve	mm	15	20	25	32	40	50	65	80	100	125	150	
	in	½	¾	1	–	1½	2	2½	3	4	–	6	
Valve without actuator	kg	6	7	8	13	15	17	31	37	49	95	135	
	lbs	13	15.5	17.5	28.7	33	37.5	68	82	108	210	298	
Weight with insulating section or bellows seal	Short	kg	9	10	11	19	21	23	40	45	68	120	165
		lbs	20	22	24	42	46.3	50.7	88	99	150	265	364
	Long	kg	13	14	15	23	25	27	44	49	76	128	173
		lbs	28.7	30.9	33	50.7	55	59.5	97	108	168	282	382

Table 6b · Type 3271 and Type 3277 Actuators

Actuator	cm ²	120	240	350	700	
	in ²	18.6	37.2	54.2	108.5	
Weight for Type 3271 without/with handwheel	w/o	kg	2	5	8	22
		lbs	4.4	11	18	48.5
	with	kg	–	9	13	27
		lbs	–	20	29	59.5
Weight for Type 3277 without/with handwheel	w/o	kg	3.2	9	12	26
		lbs	7.05	20	26.5	57.5
	with	kg	–	13	17	31
		lbs	–	29	37.5	68

Dimensional diagrams

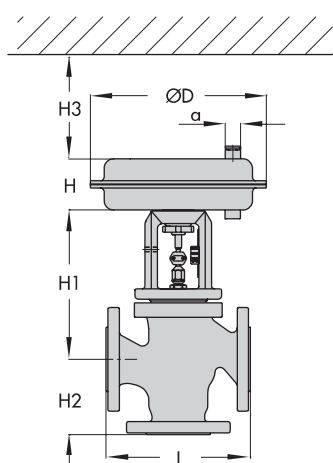

Type 3244 Valve with Type 3271 Actuator

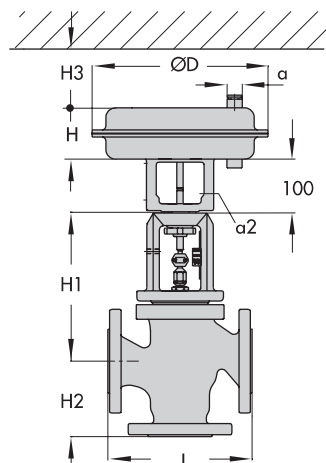

Type 3244 Valve with Type 3277 Actuator

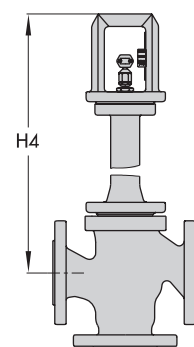

Type 3244 Valve with insulating section or bellows seal

Ordering text

Mixing or flow-diverting valve	
Nominal size	DN ... / ... in
Nominal pressure	PN ... / Class ...
Body material	According to Table 2
Actuator	Type 3271 or Type 3277
Fail-safe position	Actuator stem extends or actuator stem retracts
Process medium and its density in temperature in	kg/m ³ or lb/ft ³ °C or °F
Flow rate in in standard or operating state	kg/h or cu. ft/min
Upstream pressure	p ₁ in bar or psi (absolute pressure p _{abs})
Downstream pressure	p ₂ in bar or psi (absolute pressure p _{abs}) with minimum, normal and maximum flow rate
Accessories	Positioner and/or limit switch

Specifications subject to change without notice.

