

# Maxifluss Rotary Plug Valves

## VETEC Types 72.3/R and 72.4/R



### Application

Double-eccentric control valve for process engineering and industrial applications

**Nominal sizes** DN 25 to 400 · 1" to 16"  
**Nominal pressures** PN 10 to 40 · ANSI Class 150 and 300  
**Temperatures** –100 to 400 °C · –148 to 752 °F

Type 72.3 and Type 72.4 Maxifluss Rotary Plug Valves with

- Single-acting VETEC Type R Diaphragm Actuator

Valve body made of

- Cast steel or
- Stainless cast steel

Seat versions

- Metal sealing or soft sealing

The control valves can be equipped with various accessories such as positioners, solenoid valves, and other devices conforming to VDI/VDE 3845.

### Versions

#### Standard version

Rotary plug valves with single-acting Type R Rotary Actuator for temperatures from –100 to 400 °C (–148 to 752 °F)

- **Type 72.3/R** · DN 25 to DN 400 in flanged design, face-to-face dimensions according to DIN 3202 F1/EN 558 Series 1
- **Type 72.3/R** · 1" to 16" in flanged design, face-to-face dimensions according to ANSI B16.10/EN 558-2 Series 37 and 38
- **Type 72.4/R** · DN 25 to DN 300 in wafer-style design, face-to-face dimensions according to EN 558-1/2 Series 36
- **Type 72.4/R** · 1" to 12" in wafer-style design, face-to-face dimensions according to EN 558-1/2 Series 36

#### Further versions with

- Double packing
- TA-Luft (German clean air act) packing
- Noise-reducing features
- Heating jacket for flanged valves
- Special body and trim materials
- Wafer-style version with ceramic trim and protective sleeve for the valve body
- Version with grooved flange DIN 2512/RTJ
- Electric actuator or handwheel
- Version type tested by DVGW (German Technical and Scientific Association on Gas and Water) according to EN 161, DN 25 to 200, PN 16/40
- Basis weight control valve for paper machines

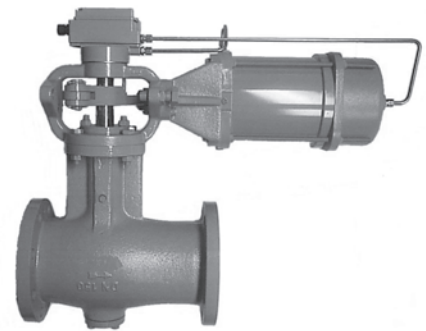

Fig. 1 · VETEC Type 72.3/R Maxifluss Rotary Plug Valve according to DIN, flanged design with Type R Pneumatic Actuator

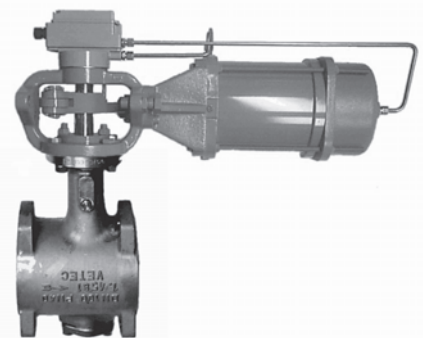

Fig. 2 · VETEC Type 72.4/R Maxifluss Rotary Plug Valve with through holes in the flange and Type R Pneumatic Actuator

### Principle of operation

The shaft and the plug are arranged eccentrically, thus implementing the double-eccentric design of the Maxifluss rotary plug valve together with the offset fulcrum (Fig. 3). This double-eccentric design ensures that the plug clears the seat immediately without any initial breakaway torque or friction when the plug shaft is turned from closed to open position. The valve opens smoothly, providing a stable control response at small opening angles.

The process medium can flow through the Maxifluss rotary plug valve in either direction.

The standard direction of flow for

- Liquids = flow to open **FTO**  
direction of flow "V"
- Gases and vapors = flow to close **FTC**  
direction of flow "H"

The flow coefficient is determined by the opening angle of the plug.

The inherent characteristic of the Maxifluss rotary plug valves can be converted into a linear or equal percentage characteristic using positioners and cam discs.

### Fail-safe position

The control valve offers two possible fail-safe positions in combination with the VETEC Type R Diaphragm Actuator in case the supply air fails:

**Valve CLOSED without supply air;** the Maxifluss rotary plug valve is closed when the supply air fails.

**Valve OPEN without supply air;** the Maxifluss rotary plug valve is opened when the supply air fails.

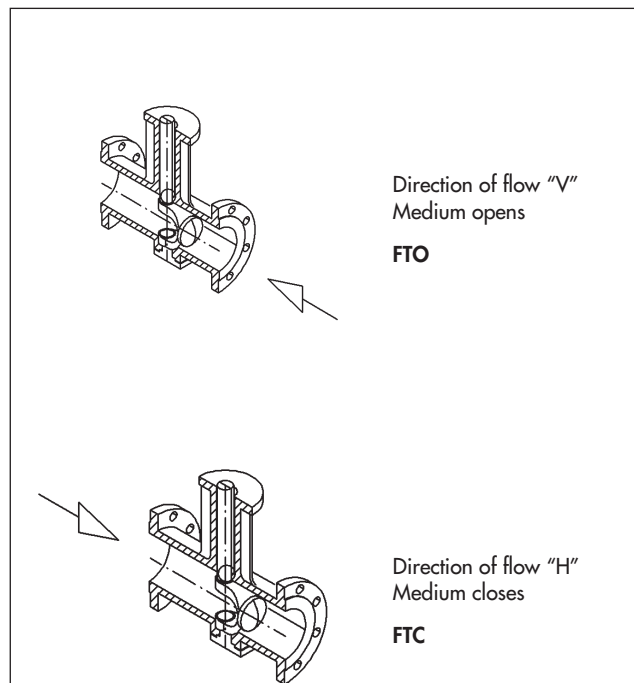
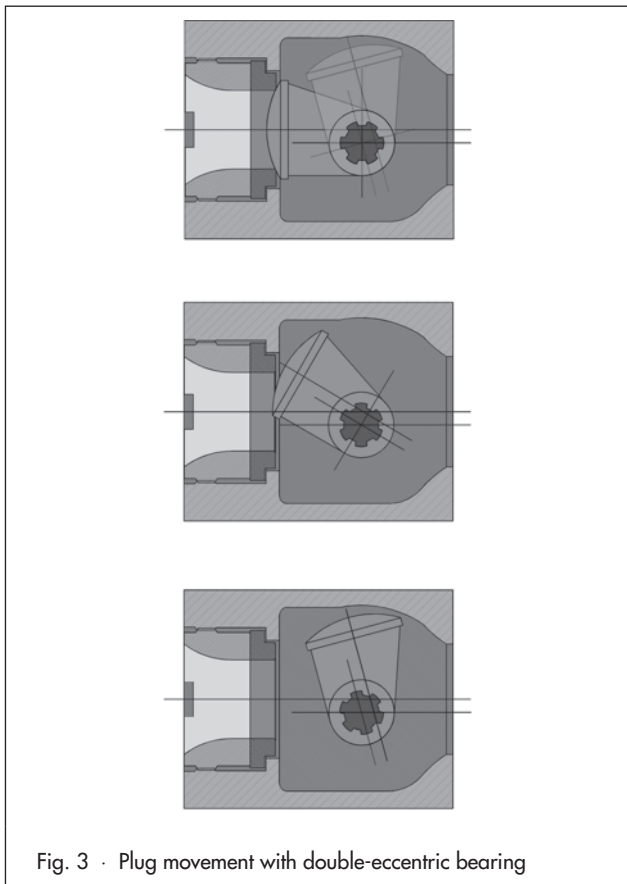

Fig. 4 and 5 · Directions of flow V and H

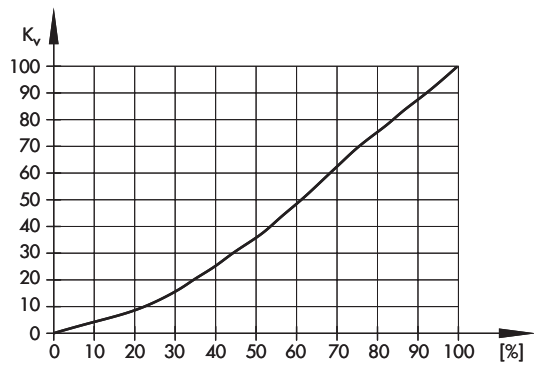

Fig. 6 · Inherent characteristic

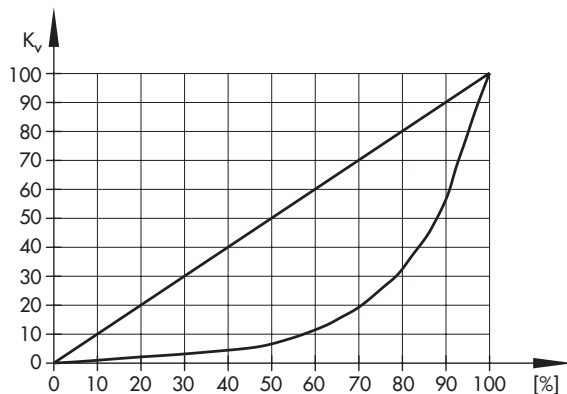

Fig. 7 · Linear and logarithmic characteristics achieved with the help of a positioner

**Table 1 • Technical data**
**Table 1a • VETEC Types 72.3 and 72.4 Rotary Plug Valves**

Maxifluss Type	72.3		72.4	
Design	Flanged		Wafer style	
Nominal sizes	DN 25 to 400	1" to 16"	DN 25 to 300	1" to 12"
Nominal pressures	PN 10 to 40	Class 150 and 300	PN 10 to 40	Class 150 and 300
Face-to-face dimensions	DIN 3202 F1 EN 558-1 Series 1	ANSI B16.10 EN 558-2 Series 37 for Class 150 Series 38 for Class 300	IEC 534-3-2 EN 558-1/2 Series 36	
Flange bores according to	PN 10, 16, 25 or 40	ANSI Cl. 150 or 300	PN 10, 16, 25 or 40	ANSI Cl. 150 or 300
Seat ring	Metal sealing · PTFE soft sealing (flow direction: FTC)			
Characteristic	Equal percentage			
Rangeability	200 : 1			
Temperature range · Other ranges available on request				
With metal sealing	-100 to 400 °C · -148 to 752 °F			
With soft sealing	-100 to 220 °C · -148 to 428 °F			
Leakage class according to DIN EN 1349				
With metal sealing	IV-L1			
With soft sealing	VI-G1			

**Table 1b • Type R Actuator**

Actuator	Type	R110	R150	R200	R250	R250V
Travel at max. opening angle	mm	128	184	200	200	200
Bench range	bar	0.4 to 1.2	0.4 to 1.2	0.4 to 1.2	0.4 to 1.2	1.3 to 2.4
Supply pressure		Min. 3 bar · Max. 6 bar				
Max. spring torque	Nm	32	84	160	249	810
Permissible ambient temperature		-20 to 70 °C · -4 to 158 °F				

**Table 2 • Materials**
**Table 2a • VETEC Types 72.3 and 72.7 Rotary Plug Valves**

Body	1.0619	1.4581
Seat	1.4571 Optionally with stellited seating surface	
Plug	1.4581 Optionally with stellited seating surface or seating surface of Stellite 6	
Shaft	1.4571	
Packing	PTFE/graphite	
Seals	Graphite/stainless steel	

**Table 2b • Type R Actuator**

Housing	Steel/aluminum
Diaphragms	NBR
Piston	Aluminum
Springs	Spring steel

**Table 3 • Control valve sizing and noise level calculation**

**Table 3a •  $K_{VS}$ ,  $C_V$ , and  $x_{Fz}$  coefficients · Seat with metal sealing · Direction of flow "V", FTO**  
 For direction of flow "H", FTC,  $K_{VS}$  is reduced by 20 %

Size	DN/in	25/1"	40/1½"	50/2"	80/3"	100/4"	150/6"	200/8"	250/10"	300/12"	400/16"
100 % $K_{VS}$	$K_{VS}$	16	40	80	245	370	685	950	1925	2680	4200
	$C_V$	19	47	94	286	430	800	1110	2252	3135	4914
	Seat Ø	18	26	36	60	76	105	135	170	210	290
	$x_{Fz 0.75}$	0.3	0.3	0.25	0.2	0.2	0.2	0.2	0.2	0.2	0.18
60 % $K_{VS}$	$K_{VS}$	10	24	48	147	220	410	570	1230	1640	2520
	$C_V$	12	28	56	171	256	477	663	1439	1918	2948
	Seat Ø	16	21.5	29.5	50	60	86	106	146	163	225
	$x_{Fz 0.75}$	0.34	0.34	0.3	0.25	0.25	0.25	0.22	0.22	0.22	0.19
40 % $K_{VS}$	$K_{VS}$	6	16	33	105	150	275	380	770	1070	1680
	$C_V$	7	19	38	122	174	320	442	900	1252	1965
	Seat Ø	14	18.5	25.5	44	53	73	88	126	133	184
	$x_{Fz 0.75}$	0.39	0.39	0.34	0.30	0.30	0.30	0.24	0.24	0.24	0.20
25 % $K_{VS}$	$K_{VS}$	4	12	20	63	93	179	240	480	670	1070
	$C_V$	5	14	23	73	108	208	279	561	784	1252
	Seat Ø	10	16	21	37	45	62	73	102	116	160
	$x_{Fz 0.75}$	0.43	0.43	0.38	0.35	0.35	0.35	0.26	0.26	0.26	0.21

**Table 3b •  $K_{VS}$ ,  $C_V$ , and  $x_{Fz}$  coefficients · Seat with soft sealing · Direction of flow "H", FTC**

Size	DN/in	25/1"	40/1½"	50/2"	80/3"	100/4"	150/6"	200/8"	250/10"	300/12"	400/16"
100 % $K_{VS}$	$K_{VS}$	10	40	68	162	252	510	726	1450	2010	3150
	$C_V$	12	47	79	189	295	593	849	1696	2351	3685
	Seat Ø	16	26	35	54	70	99	129	160	204	270
	$x_{Fz 0.75}$	0.3	0.3	0.25	0.2	0.2	0.2	0.2	0.2	0.2	0.18
60 % $K_{VS}$	$K_{VS}$	6	21	41	135	164	270	460	990	1320	2020
	$C_V$	7	24	50	158	191	314	535	1158	1535	2363
	Seat Ø	15	21.5	29.5	50	60	86	106	146	163	225
	$x_{Fz 0.75}$	0.34	0.34	0.3	0.25	0.25	0.25	0.22	0.22	0.22	0.19
40 % $K_{VS}$	$K_{VS}$	4	15	28	105	121	182	300	620	860	1345
	$C_V$	5	17	33	123	141	212	349	725	1006	1573
	Seat Ø	14	18.5	25.5	46	53	73	88	126	133	184
	$x_{Fz 0.75}$	0.39	0.39	0.34	0.30	0.30	0.30	0.24	0.24	0.24	0.20
25 % $K_{VS}$	$K_{VS}$	2	11	17	56	72	132	200	410	560	860
	$C_V$	3	13	20	65	84	153	233	479	655	1006
	Seat Ø	10	16	21	37	45	62	73	102	116	160
	$x_{Fz 0.75}$	0.43	0.43	0.38	0.35	0.35	0.35	0.26	0.26	0.26	0.21

**Table 3c •  $F_L$  and  $x_T$  coefficients**

Size	DN/in	25/1"	40/1½"	50/2"	80/3"	100/4"	150/6"	200/8"	250/10"	300/12"	400/16"
100 % $K_{VS}$	$F_L$	0.76	0.76	0.70	0.64	0.64	0.64	0.64	0.64	0.64	0.61
	$x_T$	0.5	0.5	0.5	0.35	0.35	0.35	0.30	0.30	0.30	0.30
60 % $K_{VS}$	$F_L$	0.81	0.81	0.76	0.70	0.70	0.66	0.66	0.66	0.66	0.62
	$x_T$	0.6	0.6	0.6	0.5	0.5	0.50	0.35	0.35	0.35	0.35
40 % $K_{VS}$	$F_L$	0.86	0.86	0.81	0.76	0.76	0.76	0.69	0.69	0.69	0.64
	$x_T$	0.70	0.70	0.70	0.60	0.60	0.60	0.50	0.50	0.50	0.45
25 % $K_{VS}$	$F_L$	0.89	0.89	0.85	0.82	0.82	0.82	0.72	0.72	0.72	0.65
	$x_T$	0.75	0.75	0.75	0.65	0.65	0.65	0.55	0.55	0.55	0.50

**Table 4 • Permissible differential pressures****Table 4a • Fail-safe position: valve CLOSED · Pressures in bar**

Size DN/in	Shaft Ø in mm	Max. shaft torque [Nm] at 20 °C	Actuator Type	Bench range in bar	Required supply pressure	Perm. diff. pressure for CLOSED position		Max. perm. supply pressure
						Standard flow FTO Metal sealing	Reverse flow FTC Metal or soft sealing	
25/1"	16	58	R110	0.4 ... 1.2	3	40	40	6
40/1½"	20	131	R110	0.4 ... 1.2	3	30	40	6
			R150	0.4 ... 1.2	3	40	40	
50/2"	20	131	R110	0.4 ... 1.2	3	15	40	6
			R150	0.4 ... 1.2	3	40	40	
80/3"	28	325	R150	0.4 ... 1.2	3	15	40	6
			R200	0.4 ... 1.2	3	29	40	
			R250	0.4 ... 1.2	3	40	40	
100/4"	35	586	R150	0.4 ... 1.2	3	8	40	6
			R200	0.4 ... 1.2	3	15	40	
			R250	0.4 ... 1.2	3	24	40	
150/6"	42	1246	R200	0.4 ... 1.2	3	7	40	6
			R250	0.4 ... 1.2	3	11	40	
			R250V	1.3 ... 2.4	3	40	23	
200/8"	42	1246	R200	0.4 ... 1.2	3	4	26	6
			R250	0.4 ... 1.2	3	6	40	
			R250V	1.3 ... 2.4	3	27	12	
250/10"	48	1709	R200	0.4 ... 1.2	3	2	15	6
			R250	0.4 ... 1.2	3	3	24	
			R250V	1.3 ... 2.4	3	15	7	
300/12"	48	1709	R200	0.4 ... 1.2	3	1	9	6
			250	0.4 ... 1.2	3	2	15	
			R250V	1.3 ... 2.4	3	9	4	
400/16"	72	6366	R250	0.4 ... 1.2	4	–	5	6
			R250V	1.7 ... 3.2	4	3	–	

Valves for higher pressure drops on request

**Table 4b • Fail-safe position: valve OPEN · Pressures in bar**

Size DN/in	Shaft Ø in mm	Max. shaft torque [Nm] at 20 °C	Actuator Type	Bench range in bar	Required supply pressure	Perm. diff. pressure in OPEN position		Max. perm. supply pressure
						Standard flow FTO Metal sealing	Reverse flow FTC Metal or soft sealing	
25/1"	16	58	R110	0.4 ... 1.2	3	40	40	6
40/1½"	20	131	R110	0.4 ... 1.2	3	40	30	6
			R150	0.4 ... 1.2	3	40	40	
50/2"	20	131	R110	0.4 ... 1.2	3	40	15	6
			R150	0.4 ... 1.2	3	40	40	
80/3"	28	325	R150	0.4 ... 1.2	3	40	15	6
			R200	0.4 ... 1.2	3	40	29	
			R250	0.4 ... 1.2	3	40	40	
100/4"	35	586	R150	0.4 ... 1.2	3	40	8	6
			R200	0.4 ... 1.2	3	40	15	
			R250	0.4 ... 1.2	3	40	24	
150/6"	42	1246	R200	0.4 ... 1.2	3	40	7	6
			R250	0.4 ... 1.2	3	40	11	
			R250V	1.3 ... 2.4	3	23	40	
200/8"	42	1246	R200	0.4 ... 1.2	3	26	4	6
			R250	0.4 ... 1.2	3	40	6	
			R250V	1.3 ... 2.4	3	12	27	
250/10"	48	1709	R200	0.4 ... 1.2	3	15	2	6
			R250	0.4 ... 1.2	3	24	3	
			R250V	1.3 ... 2.4	3	7	15	
300/12"	48	1709	R200	0.4 ... 1.2	3	9	1	6
			250	0.4 ... 1.2	3	15	2	
			R250V	1.3 ... 2.4	3	4	9	
400/16"	72	6366	R250	0.4 ... 1.2	4	5	–	6
			R250V	1.7 ... 3.2	4	–	3	

**Table 5 • Mounting positions for Type R Actuator**

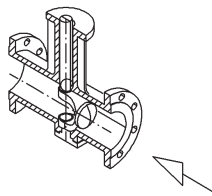

Medium opens  
Direction of flow "V"  
**FTO**

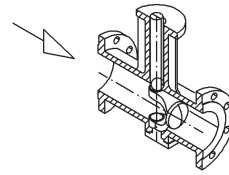

Medium closes  
Direction of flow "H"  
**FTC**

**Mounting Po • Valve CLOSED without supply air**  
Air to open - Spring closes

**Mounting Ps • Valve OPEN without supply air**  
Air to close - Spring opens

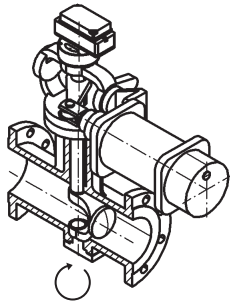

Mounting A-Po

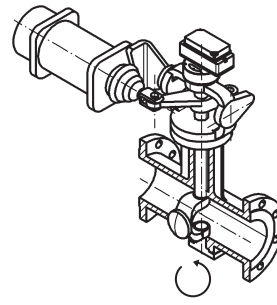

Mounting A-Ps

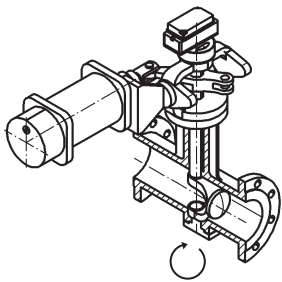

Mounting B-Po

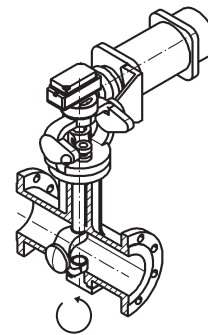

Mounting B-Ps

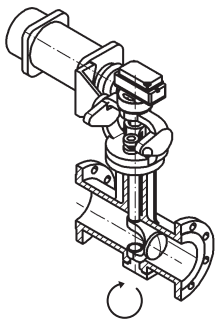

Mounting C-Po

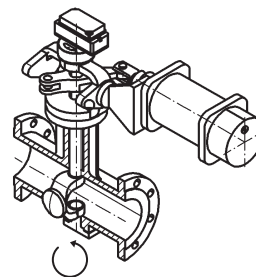

Mounting C-Ps

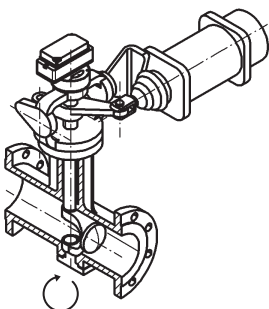

Mounting D-Po

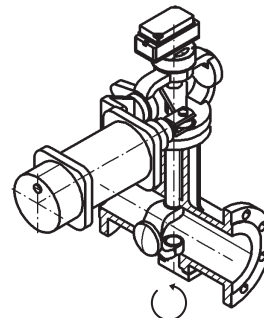

Mounting D-Ps

**Table 6 • Dimensions in mm**

**Table 6a • Type 72.3/R • DN 25 to 400 • PN 10 to 40**

Valve	DN	25	40	50	80	100	150	200	250	300	400
A		160	200	230	310	350	480	600	730	500	600
B		83	103	113	143	173	210	233	245	260	308
E		56	80	87	114	130	156	175	211	232	349
R		115									
Actuator R110											
C		242	282	292	-						
K		454	478								
N		75	100								
L		83									
P		149									
Actuator R150											
C			277	287	337	357	-				
K			593								
N		-	100								
L			119								
P			187								
Actuator R200											
C				400	420	477	492	539	561	Only use Type MN Actuator, Type R is not suitable.	
K				671							
N			-	130							
L				126							
P				240							
Actuator R250											
C				400	420	477	492	539	561	Only use Type MN Actuator, Type R is not suitable.	
K				711							
N			-	130							
L				126							
P				296							
Actuator R250V											
C				400	420	477	492	539	561	Only use Type MN Actuator, Type R is not suitable.	
K				790							
N			-	130							
L				126							
P				296							

**Table 6b · Type 72.3/R · 1" to 16" · ANSI Class 150**

Valve	in	1"	1 1/2"	2"	3"	4"	6"	8"	10"	12"	16"
A		184	222	254	298	352	451	543	673	500	600
B		83	103	113	143	173	210	233	245	260	308
E		56	80	87	114	130	156	175	211	232	349
R		115									
Actuator R110											
C		242	282	292	-						
K		454	478								
N		75	100								
L		83									
P		149									
Actuator R150											
C			277	287	337	357	-				
K			593								
N		-	100								
L			119								
P			187								
Actuator R200											
C				400	420	477	492	539	561	Only use Type MN Actuator, Type R is not suitable.	
K				671							
N		-		130							
L				126							
P				240							
Actuator R250											
C				400	420	477	492	539	561	Only use Type MN Actuator, Type R is not suitable.	
K				711							
N		-		130							
L				126							
P				296							
Actuator R250V											
C				400	420	477	492	539	561	Only use Type MN Actuator, Type R is not suitable.	
K				790							
N		-		130							
L				126							
P				296							

**Table 6c · Type 72.3/R · 1" to 16" · ANSI Class 300**

Valve	in	1"	1 1/2"	2"	3"	4"	6"	8"	10"	12"	16"
A		196	235	267	317	368	473	568	708	500	600
B		83	103	113	143	173	210	233	245	260	308
E		56	80	87	114	130	156	175	211	232	349
R		115									
Actuator R110											
C		242	282	292							
K		454	478								
N		75	100		-						
L		83									
P		149									
Actuator R150											
C			277	287	337	357					
K			593								
N		-	100			-					
L			119								
P			187								
Actuator R200											
C				400	420	477	492	539	561		
K				671							
N			-	130							
L				126							
P				240							
Actuator R250											
C				400	420	477	492	539	561		
K				711							
N			-	130							
L				126							
P				296							
Actuator R250V											
C				400	420	477	492	539	561		
K				790							
N			-	130							
L				126							
P				296							

Only use Type MN Actuator, Type R is not suitable.

**Table 6d · Type 72.4/R · DN 25 to 300 and 1" to 12" · PN 10 to 40 and ANSI Class 150/300**

Valve	DN/in	25/1"	40/1½"	50/2"	80/3"	100/4"	150/6"	200/8"	250/10"	300/12"
A		102	114	125	165	194	229	243	297	338
B		83	103	113	143	173	210	233	245	260
E		56	80	87	114	130	156	175	211	232
R		115								
Actuator R110										
C		242	282	292	-					
K		454	478							
N		75	100							
L		83								
P		149								
Actuator R150										
C		-	277	287	337	357	-			
K			593							
N			100							
L			119							
P			187							
Actuator R200										
C		-			400	420	477	492	539	561
K					671					
N					130					
L					126					
P					240					
Actuator R250										
C		-			400	420	477	492	539	561
K					711					
N					130					
L					126					
P					296					
Actuator R250V										
C		-			400	420	477	492	539	561
K					790					
N					130					
L					126					
P					296					

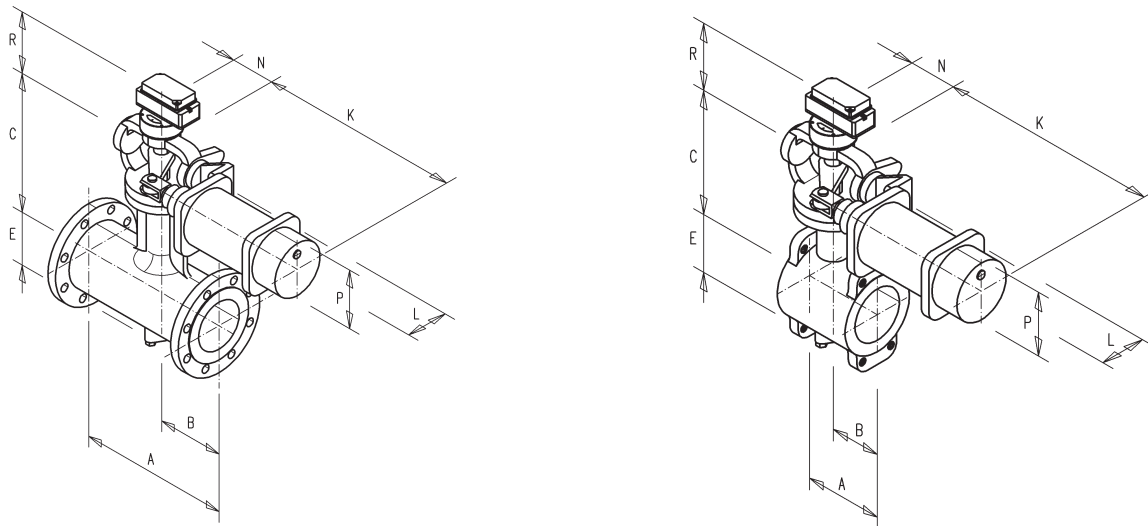

Fig. 8 · Dimensional drawings for VETEC rotary plug valves: Type 72.3 R (flanged design) and Type 72.4 R (wafer-style design)

Table 7 · Weights in kg

Valve	DN/in	25/1"	40/1½"	50/2"	80/3"	100/4"	150/6"	200/8"	250/10"	300/12"	400/16"	
Type	72.3	kg	8	15	20	40	50	100	160	220	250	450
	72.4	kg	5	8	10	20	30	60	80	140	170	–
Actuator	Type	R110		R150		R200		R250		R250V		
	kg	16		27		47		72		95		

### Ordering text

Type	According to Table 1	Actuator	Type R ....
Nominal size	DN/in ....	Mounting	According to Table 5
Nominal pressure	PN/Class ....	Fail-safe position upon supply air failure	Valve CLOSED or Valve OPEN
Body material	According to Table 2	Max. differential pressure for actuator	.... bar
Seat version	With metal sealing or soft sealing	Supply pressure	.... bar
Characteristic	Equal percentage or linear	Bench range	.... bar
$K_{VS}/C_V$ coefficient	Acc. to Tables 3a or 3b	Accessories	Positioner, limit switch, solenoid valve
Direction of flow	Standard: Flow to open = V (FTC) Reverse: Flow to close = H (FTO)	Optionally	Special versions, certificates, inspections, etc.

Specifications subject to change without notice.

