

Fulflo® SF Filter Vessels

- Carbon Steel
- 304 and 316 Stainless Steel

Multi-Cartridge Filter Vessel Series

High Flow Rates With Fulflo® SF ASME Code Vessels

Fulflo® SF Multi-Cartridge Filter Vessels meet a broad range of liquid and gas applications. All details of design, materials, construction and workmanship of the SF vessel series conform to ASME code.

The SF Vessel Series accommodates double-open-end (DOE) and single-open-end (SOE) cartridges in 10 in, 20 in, 30 in and 40 in equivalents.

Applications

- Animal Oils
- Concentrated Alkalies
- Dilute Acids & Alkalies
- Mineral Acids
- Organic Acids
- Solvents
- Oxidizing Agents
- Petroleum Oils
- Photo Solutions
- Potable Liquids
- Vegetable Oils
- Water



Features and Benefits

- Designed and fabricated in accordance with the ASME Boiler and Pressure Vessel Code, U or UM stamp.
- Non-code design and construction (parallel to code standards) available.
- Mechanical coverlifts of carbon steel construction standard on models SF12 and SF19.
- Designed for minimum pressure drop.
- External welded attachments on stainless steel models are also stainless steel.
- All SF models feature swing bolts with eyenuts for easier cleaning and servicing.
- O-ring seals provide positive closure.
- Standard Buna-N O-rings with optional Viton* elastomer, neoprene, ethylene propylene rubber and fluoropolymer elastomer O-rings are also available for temperatures up to 500°F (261°C).
- Hydraulic coverlifts optional on SF12 and SF19 models.

Process Filtration Division

Multi-Cartridge Filter Vessel Series

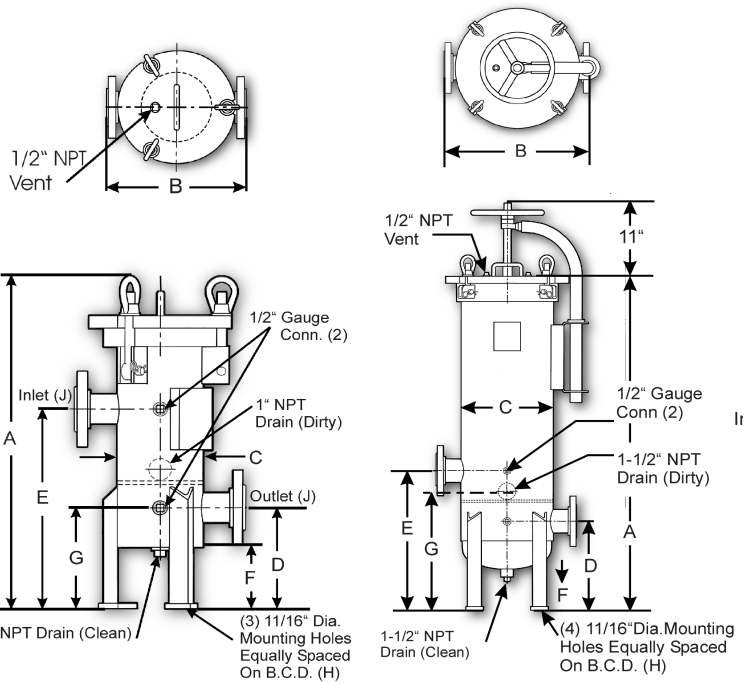

Maximum Operating Conditions

Material of Construction	Maximum Operating Pressure (psi at 250°F) [†]	Maximum Design Temperature
Carbon Steel	150 psi (10.3 bar)	500°F (261°C)
Carbon Steel	300 psi (20.7 bar)	500°F (261°C)
304 Stainless Steel	150 psi (10.3 bar)	300°F (150°C)
304 Stainless Steel	300 psi (20.7 bar)	300°F (150°C)
316 Stainless Steel	150 psi (10.3 bar)	400°F (206°C)
316 Stainless Steel	300 psi (20.7 bar)	400°F (206°C)

[†] Operating temperature limited by standard gasket material and exterior paint.

Design Specifications

Model	No. & Length of Cart. (in)	Max. Flow (gpm)	Dimensions (in)									Shipping Weight (lbs)
			A [†]	B	C	D	E	F	G	H	J ^{††}	
SF3-1-2F	(3) 10	15	26-11/16	12-7/8	6-5/8 OD	8-3/16	16-3/16	5	11-5/16	5-13/16	2	125
SF6-1-2F	(6) 10	30	26-15/16	14-7/8	8-5/8 OD	8-3/16	16-3/16	5-1/16	11-5/16	7-7/8	2	180
SF6-2-2F	(6) 20	60	37	14-7/8	8-5/8 OD	8-3/16	16-3/16	5-1/16	11-5/16	7-7/8	2	185
SF6-3-2F	(6) 30	90	47-1/16	14-7/8	8-5/8 OD	8-3/16	16-3/16	5-1/16	11-5/16	7-7/8	2	200
SF6-4-3F	(6) 40	120	58-1/2	14-7/8	8-5/8 OD	8-3/16	16-3/16	5-1/16	12	7-7/8	3	220
SF12-3-3F	(12) 30	180	50-3/16	20-1/2	12-1/16 ID	13-3/8	21	5	17-7/8	12-1/8	3	310
SF12-3-4F	(12) 30	180	50-3/16	20-1/2	12-1/16 ID	13-3/8	21	5	17-7/8	12-1/8	4	315
SF12-4-4F	(12) 40	240	60-5/16	20-1/2	12-1/16 ID	13-3/8	21	5	17-7/8	12-1/8	4	330
SF19-3-4F	(19) 30	285	50-3/16	23-1/2	15-1/16 ID	13-3/8	21	5	17-7/8	15-1/4	4	420
SF19-4-4F	(19) 40	380	60-5/16	23-1/2	15-1/16 ID	13-3/8	21	5	17-7/8	15-1/4	4	440

[†] Add 5 in to this dimension for hydraulic coverlift.

^{††} Inlet and outlet size standard ASA flanges.

Ordering Information

Material	Design Series	Number of Columns	Cartridge Length (in)	Inlet/Outlet Flange Size	Coverlift Option
No Symbol = Carbon Steel	SF = 304 Stainless Steel	3	1 = 10	2	K1 = Mechanical
4 = 304 Stainless Steel	SF = 316 Stainless Steel	6	2 = 20	3	K2 = Hydraulic
6 = 316 Stainless Steel	HSF = 300 PSI Design	12	3 = 30	4	
	CSF = Non-Code Design	19	4 = 40		

Process Filtration Division

* A trademark of E. I. du Pont de Nemours & Co.

Parker Hannifin Corporation
 Process Filtration Division
 P.O. Box 1300
 Lebanon, Indiana 46052
 Toll Free 1-888-C-FULFLO (238-5356)
 Telephone (765) 482-3900
 Fax (765) 482-8410
<http://www.parker.com>

