

SHARPE[®] VALVES

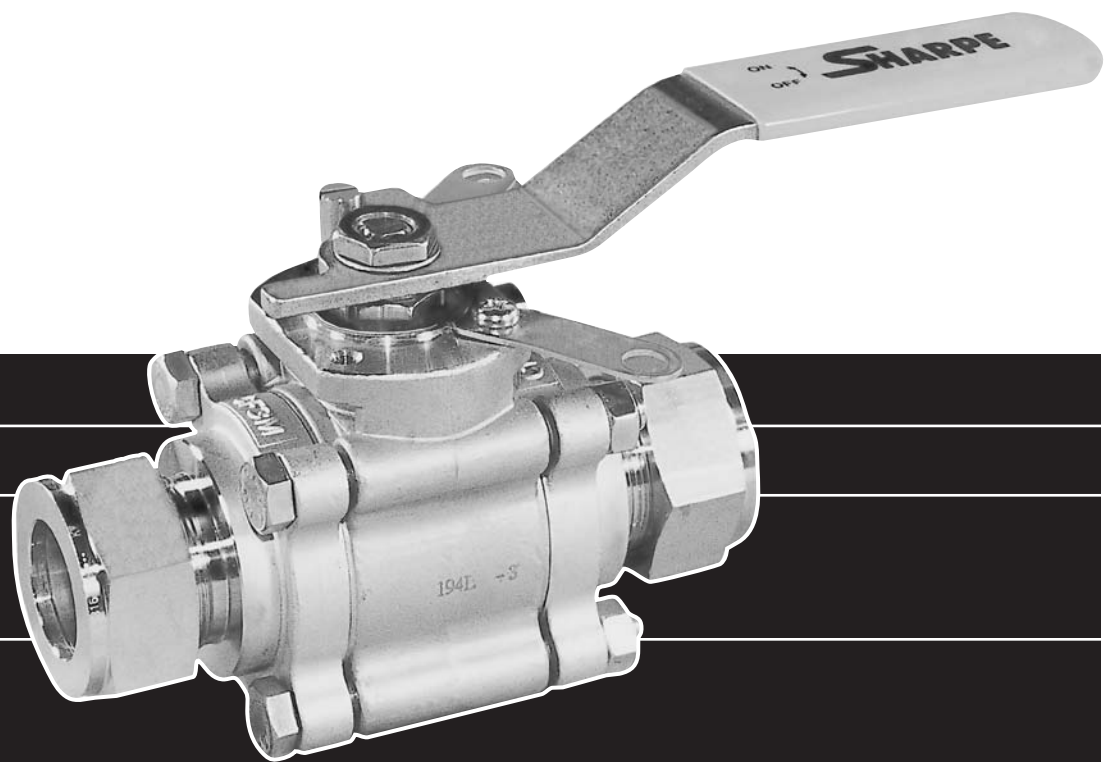

**SERIES 86
INSTRUMENTATION 3-PIECE
TUBE FULL PORT BALL VALVES**

SHARPE® SERIES 86

INSTRUMENTATION BALL VALVES

STANDARD FEATURES

Tube Full Port Design (TFP)

3-Piece Design

Integral ISO Mounting Pad

Lockable Handle

Variety of End Connections

Variety of Purge Ports

High Cycle Stem Design

Floating Ball Design

Encapsulated Body Bolts

Traceability

Variety of Seats

ADVANTAGES

Tube full-port maintains unrestricted flow of media. Eliminates pressure drops.

In-line serviceable swing out center section allows easy access to internal valve components without disturbing alignment of tubing. Functions as both valve and union.

Actuation centering lip feature assures precise alignment of bracket, stem and coupler. Actuators may be retro-fit on existing 86 Series valves without disruption of line integrity. Allows for secondary containment unit to be added when required.

All Sharpe® Series 86 Valves meet OSHA standards with locking device. Prevents valves from being opened or closed accidentally.

Instrumentation Ends with any other end connections, Clamp, Butt weld, Extended Butt weld, Socket Weld and Butt weld (IPS) or with 150#/300# RF Flange.

Compression Fitting Purge or Threaded Male/Female Purge can be ordered on valve ends or valve body.

Live loaded, bottom entry, blowout proof anti-static stem features live loaded packing that extends valve cycle life over conventional ball valves and is the best choice for actuation.

Precision engineered solid stainless steel ball is bi-directional and seals downstream. Consequently, it provides a bubble-tight shut-off with very little particle generation.

Heavy duty stainless steel bolting is protected from outside environment and is ideal for washdowns.

Heat numbers are provided for all valve bodies and ends. CMTR's (Certified Mill Test Reports) are available upon request.

Teflon, Reinforced Teflon, PTFE-TFM®, Delrin, Nova, Peek, Cavity Filler made from Teflon or PTFE-TFM®.

SERIES 86 VALVE PARTS AND IDENTIFICATION

1/4" - 2"

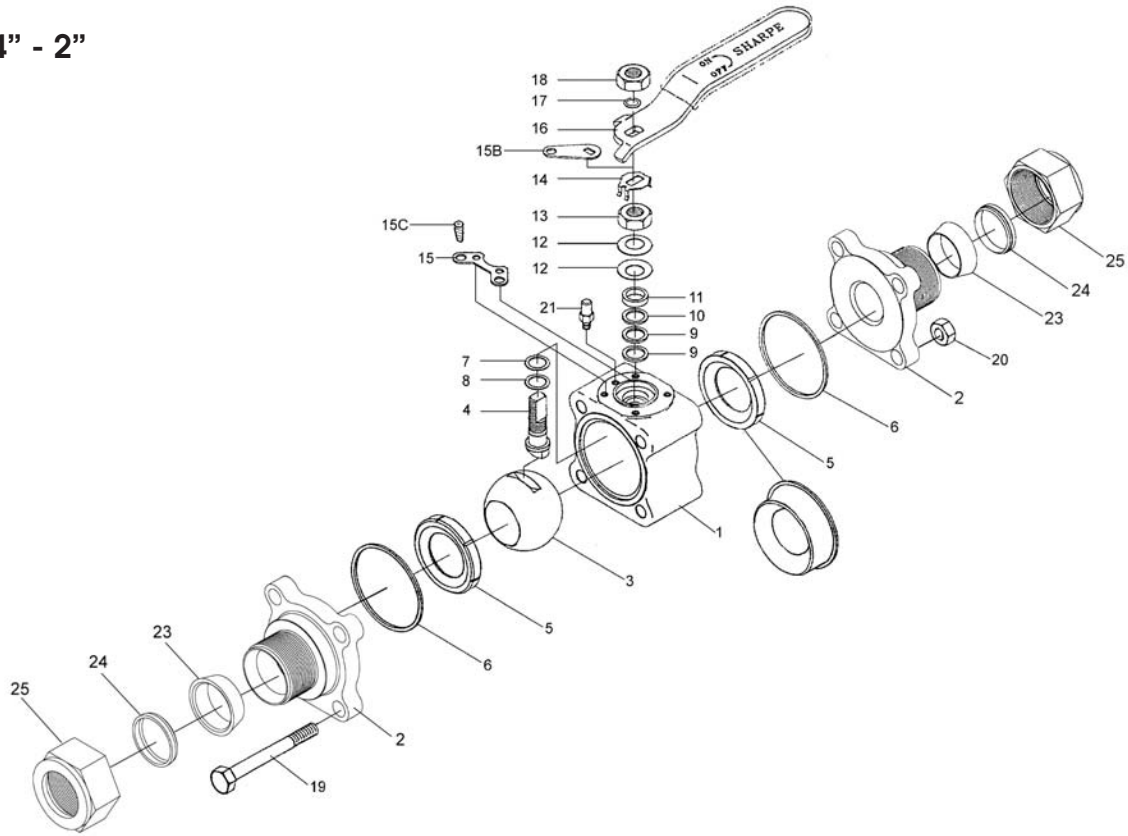

PART NO.	PART	QTY.	MATERIAL
1	Body	1	316L CF3M ASTM 351
2	Pipe Ends	2	316L CF3M ASTM 351
3	Ball	1	316L
4	Stem	1	316L
5	Valve Seat	2	Teflon PTFE-TFM Nova Cavity Filler (Teflon or PTFE-TFM) Reinforced Teflon Delrin Peek
6	Valve Seal	2	Teflon PTFE-TFM Viton Graphoil
7	Thrust Bearing	1	Nova* / PTFE-TFM
7A	Stem Location Ring (3" & 4")	1	Stainless Steel
8	Thrust Bearing	1	Peek / PTFE-TFM
8A	Thrust Bearing	1	Nova* / PTFE-TFM
9	Stem Packing	2	Nova* / PTFE-TFM
10	Seal Protector	1	Peek / PTFE-TFM
11	Gland Packing	1	Stainless Steel
12	Belleville Washer	2	Stainless Steel
13	Packing Nut	1	Stainless Steel
14	Lock Tab	1	Stainless Steel

PART NO.	PART	QTY.	MATERIAL
15	Lower Lock Latch	1	Stainless Steel
15B	Upper Lock Latch Bolt	1	Stainless Steel
15C	Latch Bolt	1	Stainless Steel
16	Handle (1/4"-2")	1	Stainless Steel
17	Lock Washer	1	Stainless Steel
18	Handle Nut (1/4"-2")	1	Stainless Steel
19	Body Bolts	4	Stainless Steel
19A	Body Connector Nut	8	Stainless Steel
20	Nuts	4	Stainless Steel
21	Stop Pin	1	Stainless Steel
21A	Stopper	1	Stainless Steel
22	Seat Retainer	1	Stainless Steel
23	Front Ferrule	2	Stainless Steel AISI 316
24	Back Ferrule	2	Stainless Steel AISI 316
25	Nut	2	Stainless Steel AISI 316 Silver Plated

* Nova: Carbon and Graphite Filled Teflon

SERIES 86 VALVE DIMENSIONS

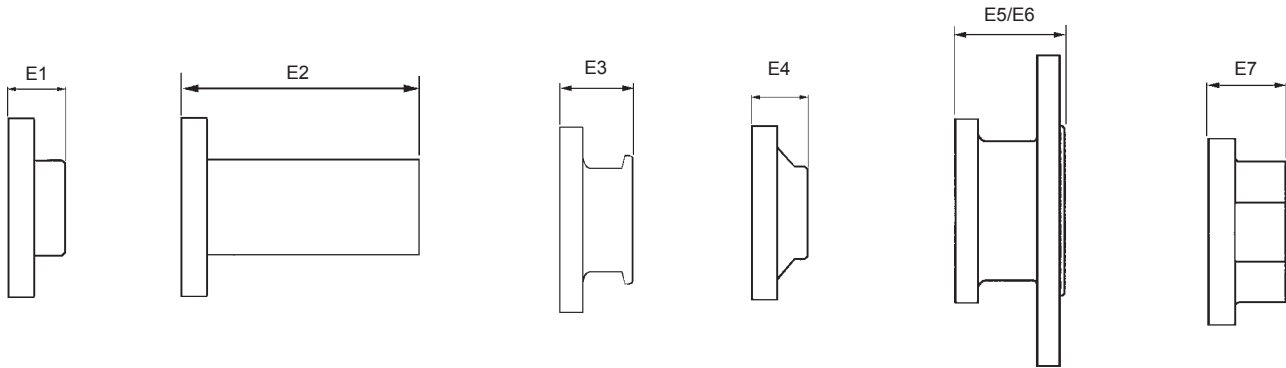
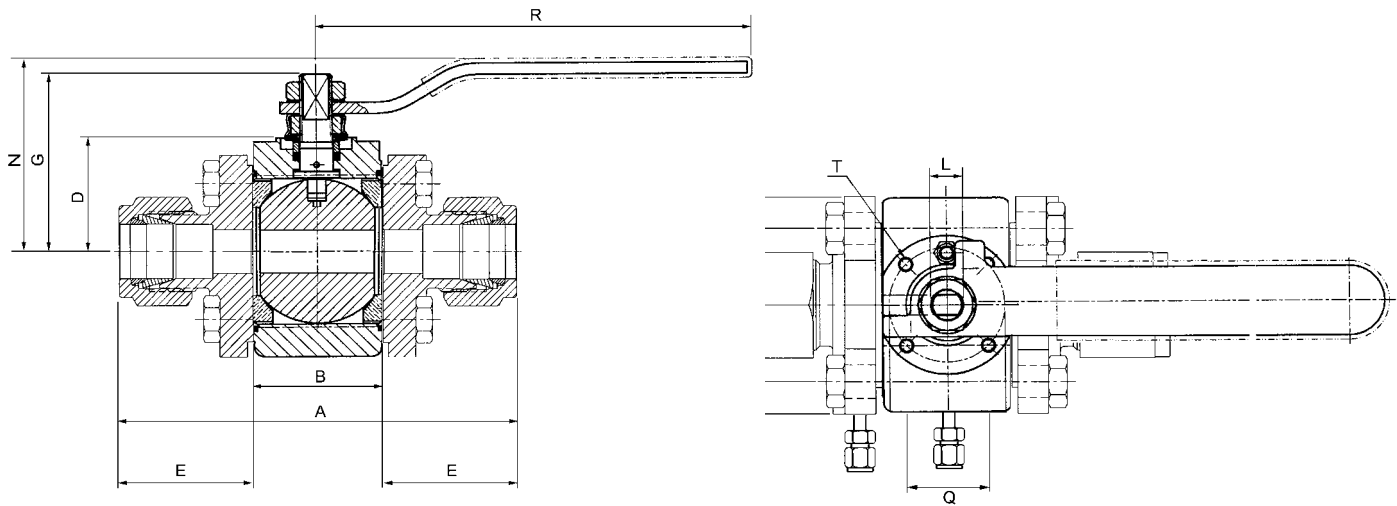

SIZE	A	B	C	D	E	F	G	L	M	N	Q	R	T	V	PORT	E ¹	E ²	E ³	E ⁴	E ⁵ /E ⁶	E ⁷
1/4"	3.90	.97	1.25	.939	1.46	1.75	1.50	3/8"-24	.22	1.76	1.00	5.53	M5	.28	.37	.76	2.26	1.26	.90	2.35	.87
3/8"	3.90	.97	1.25	.939	1.46	1.75	1.50	3/8"-24	.22	1.76	1.00	5.53	M5	.28	.37	.76	2.26	1.26	.90	2.35	.87
1/2"	4.11	.97	1.25	.939	1.57	1.75	1.50	3/8"-24	.22	1.76	1.00	5.53	M5	.28	.37	.76	2.26	1.26	.90	2.35	.87
3/4"	4.20	1.05	1.50	1.24	1.57	2.05	1.59	3/8" UNF	.22	1.87	1.00	4.50	M5	.28	.62	.84	2.48	1.48	1.25	2.52	.90
1"	5.25	1.54	1.75	1.51	1.85	2.42	2.19	7/16" UNF	.30	2.40	1.18	5.75	M5	.30	.87	1.05	2.48	1.48	1.30	2.63	1.22
1-1/2"	7.55	2.13	2.25	1.71	2.71	3.16	2.88	9/16" UNF	.35	3.16	1.38	7.00	M6	.42	1.37	1.18	2.68	1.69	1.32	2.80	1.33
2"	9.95	2.66	2.62	1.87	3.65	3.56	3.06	9/16" UNF	.35	3.35	1.38	7.00	M6	.42	1.87	1.12	2.68	1.80	1.40	3.14	1.40

E = IE (INSTRUMENTATION END)
 E¹ = BE (TUBE BUTTWELD END)
 E² = BTE (BUTTWELD TUBE EXTENDED END)

E³ = CE (CLAMP END)
 E⁴ = BW (IPS BUTTWELD END)
 E⁵ = 150# RF FLANGE END

E⁶ = 300# RF FLANGE END
 E⁷ = TE/SW (THREADED NPT/SW END)

*E DIMENSION ONE END ONLY

**E⁵/E⁶ IN 1/4", 3/8" VALVES, FLANGES ARE 1/2"

AVAILABLE OPTIONS

Mechanical Polishing for Body CE and BE

Available to 320 Grit (10 Ra).
Improves machined surface by removing entrapment areas and adding a high luster appearance.

Electro-Polishing

Improves surface finish of mechanical polishing up to 50%.
Passivates surface for increased corrosion resistance.
Removes any entrapped contaminants.

Purge Ports

Available on bodies or ends.
These ports are suitable for CIP (clean in place) and SIP (sterilize in place) applications.

Preparation for Oxygen Services and Silicone-Free Services

PRESSURE TEMPERATURE DATA

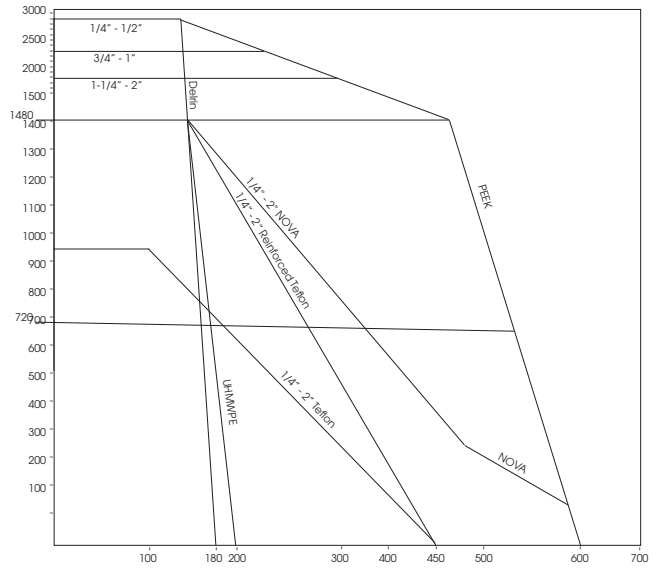

STEAM SPECIFICATIONS

SATURATED STEAM			
PRESSURE		EQUIVALENT TEMPERATURE	
P.S.I.G.	BAR	°F	°C
0	0	212	100
15	1.0	250	121
50	3.45	298	148
100	6.9	338	170
150	10.3	366	186
200	13.8	388	198
250	17.2	406	207
300	20.7	421	216
350	24.1	435	224
400	27.6	448	231
500	34.5	470	243
600	41.4	489	254

STEAM RATINGS*

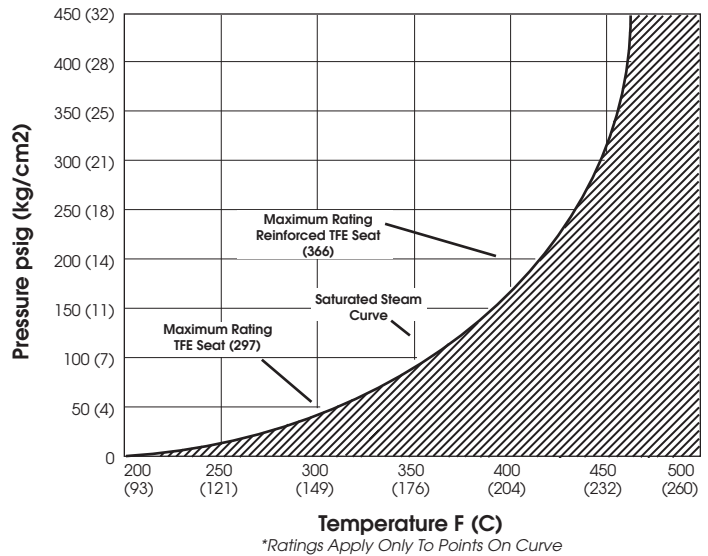

ASSEMBLY INSTRUCTIONS

TUBE FITTING ENDS

1. Insert tubing into valve end making sure the tubing seats firmly against the shoulder of the body and the nut is finger tight.
2. Tubing must be seated flush with counter bore to ensure proper sealing.
3. Tighten the nut, with proper wrench, 1-1/4 turns while holding valve body.

SHARPE® VALVES

Choose from our full line of high quality valves and actuators to meet your needs.

Whatever your flow control requirements are, Sharpe® has the right products and service to meet your needs today.



HOW TO ORDER

VALVE SIZE	VALVE SERIES	BODY	BALL & STEM	SEATS	SEALS	ENDS	SPECIAL OPTIONS
1/4" 3/8" 1/2" 3/4" 1" 1-1/2" 2"	86	6 = Stainless Steel	6 = Stainless Steel	T = Teflon M = PTFE-TFM® R = RTFE D = Delrin N = Nova C = Teflon Cavity Filled F = PTFE-TFM® Cavity Filled	T = Teflon G = Graphoil M = PTFE-TFM® B = Buna V = Viton	IE = Instrumentation End CE = Clamp BE = Tube Buttweld BTE = BW Tube Extended BW = IPS Buttweld Schedule 5/10/40 F1 = 150# RF Flange F3 = 300# RF Flange TE = Threaded Ends (NPT) TEB = Threaded Ends (BSPT) SW = Socket Weld	EP = Electro Polish 2 = 240 GRIT / 15-20 RA* 3 = 320 GRIT / 9-11 RA* PP = Purge Port 5 = Tube 6 = Compression Fitting 7 = Male NPT 8 = Female NPT X = Oxygen Service OH = Oval Handle SF = Silicon Free

3/4" 86 6 6 R CE PP5

*Polishing not including IE.
Teflon® is a registered trademark of E.I. DuPont.
PTFE-TFM® is a registered trademark of Dyneon.

SHARPE® VALVES

A Division of Smith-Cooper International, LLC

Toll-Free 1-877-7SHARPE
(877) 774-2773

Fax: (708) 562-9250

E-Mail: info@sharpevalves.com

www.sharpevalves.com

1260 Garnet Drive

Northlake, Illinois 60164 U.S.A.