

Installation, Operation, and Maintenance Manual

GEBCO 2™ SERIES

Pneumatic Actuators



MODEL: GEBCO 2™ 032, 050, 063, 075, 085, 100, 115, 125, 145, 160, 180, 200, 240, 265, 300, 350, & 400.

WARNING AND SAFETY INSTRUCTIONS:

1. Read this Installation, Operation & Maintenance manual before using the actuator.
2. George E. Booth Co., Inc. cannot anticipate all of the situations a user may encounter while installing and using the GEBCO 2™ Actuator. The user must know and follow all applicable industry specifications on the safe installation and use of these actuators. Only qualified personnel or technicians who are trained for maintenance work and have read the instructions are to assemble and disassemble the actuator. Misapplication of the product may result in injuries or property damage.
3. Before operating an actuator which is connected to a valve in the pipeline, make sure you know the valve function.
4. Make sure the actuator is not connected to the air supply or electrical system before attempting to do any maintenance.
5. Before removing the actuator from the valve, always make sure the line has been depressurized and drained. Cycle the valve a few times to relieve any pressure that could be trapped in the body cavity.
6. Use only **GEBCO 2™** components and spare parts supplied in the **repair kits**.
7. Do not use air pressure to remove actuator pistons when covers have been removed.
8. Do not leave any grip key or shaft connection attached to the actuator, or try to manually operate the actuator while it is still connected to the air supply.
9. The user must follow and observe any national or local safety law imposed for his system.

STORAGE

The GEBCO 2™ Actuator has been packaged to provide protection during shipment and storage. It is however, possible that the actuator can be damaged during transport. Inspect actuator for shipping damage prior to storage. Keep the actuator in their original boxes and store indoor in a clean dry environment until ready for use. Keep plastic plugs in the air ports to prevent liquids or other materials from entering the actuator during storage. It is recommended to stroke them periodically to prevent setting of seals.

LUBRICATION:

The actuators are pre lubricated from the factory and under normal operating conditions do not require re-lubrication. In the event of actuator maintenance it is recommended to use the following lubricants:
For NBR O-rings use EP1. The lubricant is suitable for use from -20°C to +80°C (-4°F to +176°F) with AIT/Flashpoint> (T-class +50K).

For Viton O-rings use Molykote 111 or OKS 1110. The lubricant is suitable for use from -40°C to +140°C (-40°F to +284°F).

For EPDM O-rings use only Silicone grease.

SUPPLY PRESSURE

Double-acting and Spring Return:

Max. 8 Bar (116 PSI), Minimum 3.0 Bar (40 PSI)

When sizing an actuator to available air supply, make sure you have adequate power in the actuator to allow the valve to complete its operation and leave enough power for safety margin.

AIR SUPPLY

Use clean dry air. Do not use water as supply media.

Do not operate the actuator by using flammable, oxidizing and corrosive, explosive or unstable gasses.

Oxygen or hydrogen must not be used.

The operating medium is to be filtered to 30 micron particle size or less. Always consult with a representative of GEBCO 2™ for suitability and recommended practice. Piping connected to the actuator or accessories should be fitted according to recommended instrumentation piping practice. Prior to connection make sure all lines have no loops and are free of water, oil or other contaminants that may be trapped in the pipes. Pipes must be flushed with air to clean the passages. Where sealants are being used for threaded connections, care must be taken to avoid excess material being forced into the actuator ports.

OPERATING TEMPERATURE

The standard temperature limits for the GEBCO 2™ actuators are:

Maximum +80°C (+176°F), Minimum -20°C

Temperatures below or above these figures special preparation and materials are required such as grease, O-rings, pinion bearing and pads. The GEBCO 2™ maximum working temperature is 130°C (266°F) when used with Viton O-rings and HT grease. The minimum working temperature is -40°C (-40°F) when used with EPDM O-rings and LT grease. For temperatures below -40°C (-40°F) please consult with representative. When used in sub-zero temperatures it is essential to use an air dryer for the supply to avoid any moisture. Always consult with representative of GEBCO 2™ for suitability and recommended practice.

PRINCIPLE OF OPERATION

The GEBCO 2™ actuator is a two piston Rack & Pinion pneumatic actuator. Air pressure applied to the piston surface area generates thrust which transforms linear motion to rotary motion of the pinion.

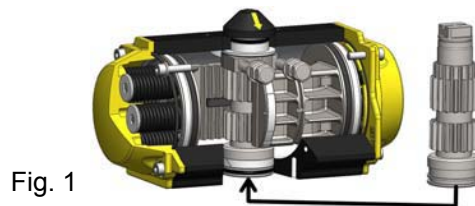

AIR CONNECTIONS

The actuator air connections are marked **A** and **B**. Both are NPT ports. Check the catalog/website for thread sizes. Port B connects to a chain of holes to two pistons. The air passes into the body wall and come out in two places in the cylinder near the cover. Each piston receives the air flow from two directions which ensures a quick response.

Looking from the top of the actuator.
A port is on the left ; **B port** is on the right

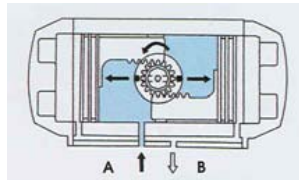

Fig. 2

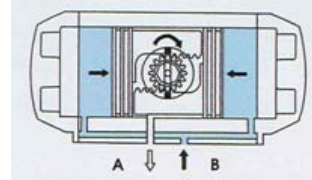

Fig. 3

Double Acting (DA)

Fig. 2: Pressure entering port **A** to open. Center chamber pushes the pistons outward and rotates the pinion **CCW** (counter clockwise).

Fig. 3: Pressure entering port **B** to close. The outer chamber pushes the pistons inward and rotates the pinion **CW** (clockwise).

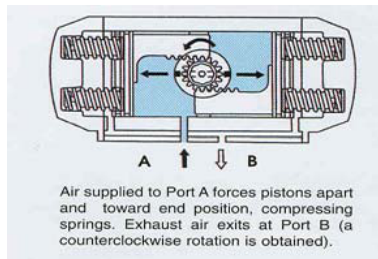

Fig. 4

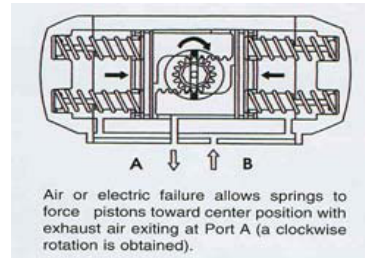

Fig. 5

Spring Return (SR)

Fig. 4: Pressure entering port **A** to open. Pressure at center chamber pushes the pistons outward and rotates the pinion **CCW** (counter clockwise).

Fig. 5: Air released from center chamber exiting at port A. Spring pushes the pistons inward, pinion rotates **CW** (clockwise).

NAMUR Solenoid Mounting

Air supply connection is done by mounting a solenoid (Fig. 6) directly onto a mounting pad conforming to the Namur standards. (*only Solenoids made to the NAMUR standard can be mounted in this way.*) The GEBCO 2™ actuator can also be piped with solid or flexible tubing from remote solenoid valves.



Fig. 6

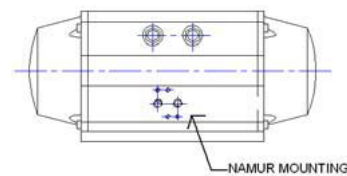

Fig. 7

FRONT VIEW

ISO 5211 or DIN 3337

The actuator bottom flange is in accordance with ISO 5211 (or DIN 3337) International standard and incorporates a star shaped female drive (Fig. 8) for flexibility to fit various valve output shafts. The valve can be attached by bracket or mounted directly onto the actuator, using one of the various ISO hole patterns. Please refer to the GEBCO 2™ catalog for dimensions or visit our website at "www.gebooth.com".

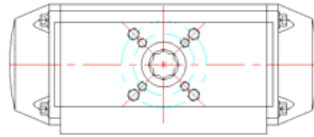

Fig. 8

Bottom View

Travel Adjustment

The actuator comes factory adjusted to produce 90° rotation with options available for 120° and 180°. The rotation is restricted by adjustment of stop bolts (2) which provide fine tuning or a limiting stroke.

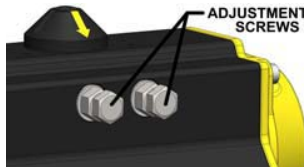

Fig. 9

The standard stop bolts allow adjustment of $\pm 5^\circ$ in the travel limits.

Disassembly

General

Before performing any disassembly operations make sure you read all the warnings and safety instructions in this leaflet.

Do not attempt to disassemble the actuator while it is still connected to the valve or to any ancillary. Verify that the actuator is not pressurized. Check if the air ports are vented and spring return actuators are in the fail close position.

Work in a clean area, free of dust, debris, greased, corrosives, and moisture. For security and comfort do the repairs on a table with a vise and available air supply.

1. Disassembly of Covers

- 1.1 For spring return actuators; Springs in the actuator are pre-loaded. Loosen the cover screw gradually in sequence by turning opposing screws two rotations at a time to release springs.
- 1.2 Remove the covers making sure not to damage the O-ring seals (14).
- 1.3 Remove the springs (17) from the cylinder and lay them together with their covers for the assembly stage.
- 1.4 Follow the same routine on the other end.

2. Loosen the Stop Bolt

- 2.1 Loosen the Stop Nut (04) first then loosen the Stop Bolt (02). Remove the Washer (03) and O-Rings (11). Check and replace damage O-rings.

3. Pistons Disassembly

- 3.1 Place the coupler to the vise then place the actuator on top of the coupler. With the bottom hole of the actuator engaged with the coupler. The ports facing towards you, hold the actuator body on both ends and turn clockwise until the pistons protrude further out from the cylinder to be removed.

Note: If the piston is fail counter clockwise, Body must be rotated in opposite direction.

- 3.2 Remove the pistons by hand or with pliers. Caution not to damage the pistons surfaces.
- 3.3 Remove the piston O-rings (16) and piston bearings (15) if replacing all soft components.

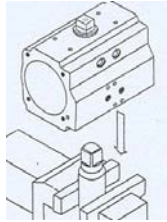

Fig 10

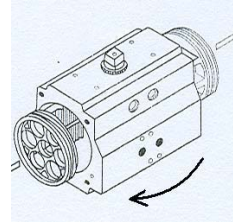

Fig 11

4. Pinion Shaft Disassembly

- 4.1 Remove the snap-ring (18) using the snap-ring pliers.
- 4.2 Apply downward force to top of pinion until it is partially out of the bottom of the body. Then pull the pinion completely. When the pinion does not come out freely, hit the top with a rubber mallet or gently tap with a rubber/wooden mallet or hammer.
- 4.3 Remove top and bottom pinion bearings (06 & 07), and O-rings (20 & 21). If replacing all soft components. When all components are disassembled, those are not being replaced should be inspected for wear before being greased and reassembled.

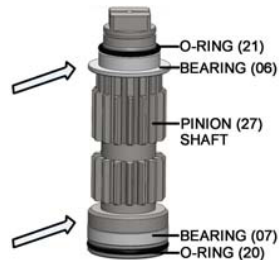

Fig 12

5. Pinion Shaft Assembly

Prior to assembly, ensure all components are perfectly clean and free from damage. Please see Lubrication above.

- 5.1 Install top and bottom pinion bearings (6 & 7) and top and bottom pinion O-rings (20 & 21).
- 5.2 Apply grease to the surface of the drive shaft.
- 5.3 Insert the pinion shaft partially from the bottom of the body. The shaft protruding at the cylinder.
- 5.4 Install the stroke adjustment stop thru the cylinder to the pinion shaft in the correct position shown in figure # 13.

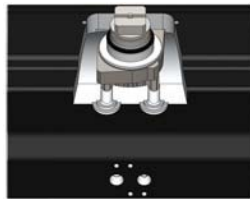

Fig 13

- 5.5 Insert the snap ring (18) to the pinion shaft.

6. Piston Assembly

- 6.1 Install piston O-rings (16), the piston bearing (15).
- 6.2 Apply grease to the contact surfaces and rack of the pistons.
- 6.3 Insert the two pistons in the cylinders, keeping the orientation of the racks so the teeth is engaged with the pinion teeth.

- 6.4 Hold both ends of the body with both hands, apply pressure to the pistons until pistons are flush to the body.
- 6.5 Place the actuator on top of the couple in the vise.
- 6.6 Rotate the body CCW until both pistons are pulled inside. Make sure the pistons have reached the same position in the cylinder.
- 6.7 Insert the stop bolt back until the end rest to the face of the adjustment stop.
- 6.8 Rotate the body back 90°CW to the open position so the pistons are now almost flush with the actuator body.
- 6.9 Screw the other stop bolt back until they touch the stop.
- 6.10 Rotate the body back and forth to get the pistons running smoothly in the cylinder.
- 6.11 Bring the pistons in to the close position and once again apply grease in the cylinders behind the pistons.

7. End Cap Assembly.

- 7.1 Apply grease to all the spring sets.
- 7.2 Push the cover O-ring (14) in the groove of the covers. If needed, replace them with a new set.
- 7.3 For spring return, place the body in vertical position, place the spring set inside. Insert the screws. Tighten the screws in sequence and only two turns at a time.

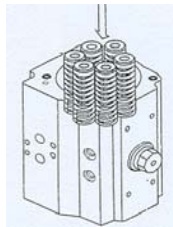

Fig 14

8. ADJUSTMENT INSTRUCTIONS

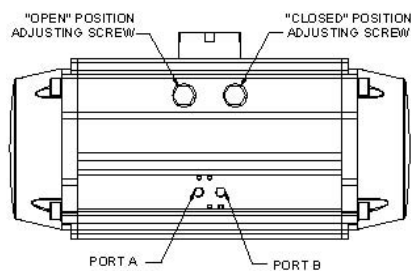

Fig 15

- 8.1 On double acting actuators, air supplied to Port B will cause the actuator shaft (and position indicator) to rotate Clockwise, towards the “valve closed” position. Spring return actuators (fail closed) will rotate in this direction by spring force alone.
- 8.2 To adjust the “Valve Closed” position (as observed on the position indicator), loosen the jam nut on the right hand adjusting screw (above Port B) and turn the screw clockwise to rotate the shaft counterclockwise. Turning the adjusting screw counterclockwise will cause the shaft to rotate clockwise.

Note: For double acting actuators, it will be necessary to apply air to Port B after adjusting the screw counterclockwise to rotate the position indicator and check the adjustment. Repeat as needed.

- 8.3 On double acting actuators, air supplied to Port A will cause the actuator shaft (and position indicator) to rotate Counterclockwise, towards the “valve open” position.
- 8.4 To adjust the “Valve Open” position (as observed on the position indicator), loosen the jam nut on the left hand adjusting screw (above Port A) and turn the screw clockwise to rotate the shaft clockwise. Turning the adjusting screw counterclockwise to rotate the shaft to counterclockwise.

Caution

Do not attempt any adjustments while the actuator air supply is on,
and the actuator is under pressure.

Actuator Testing

After the proper adjustment has been accomplished, it is required to follow these testing procedures to ensure the actuator is assembled correctly and to minimize the risk of personal injury.

Pneumatic Leak Test

The pneumatic test checks there is no leakage across the pistons or to environment. Use commercial leak testing solution to check leakage to atmosphere. It is acceptable to allow a small amount of leakage to atmosphere. A bubble which breaks every 10 seconds is considered acceptable. The leak testing pressure will be 80 psig (5.5 barg). Use a calibrated pressure regulator to apply pressure to the actuator. **Warning: Do not exceed the maximum operating pressure rating listed on the nameplate.** Cycle the actuator at least 5 times to allow the seals to find their position before commencing with the leak test.

Piston Leakage

Any leakage across the piston is not acceptable.

- 1.0 Apply the pressure to port A and leave port B open.
- 2.0 Apply a leak testing soap solution to port B and check for leakage.
- 3.0 For DA actuators repeat this applying pressure to port B and check port A for leakage.
- 4.0 If Leakage is observed, disassemble the actuator again and check the seal, surface finish and cleanliness of the internal parts to find the cause of leakage. After doing the repair work, the leakage test must be performed again.

External Leakage

For SR actuators apply the pressure to port A and leave port B open. For DA actuators apply the pressure to port A and B. After applying pressure, wait a few seconds to let the pistons stabilize and then check for leakage. Apply the leak testing solution to the pinion output. For DA actuators apply the leak testing solution to the covers.

PARTS AND IDENTIFICATION

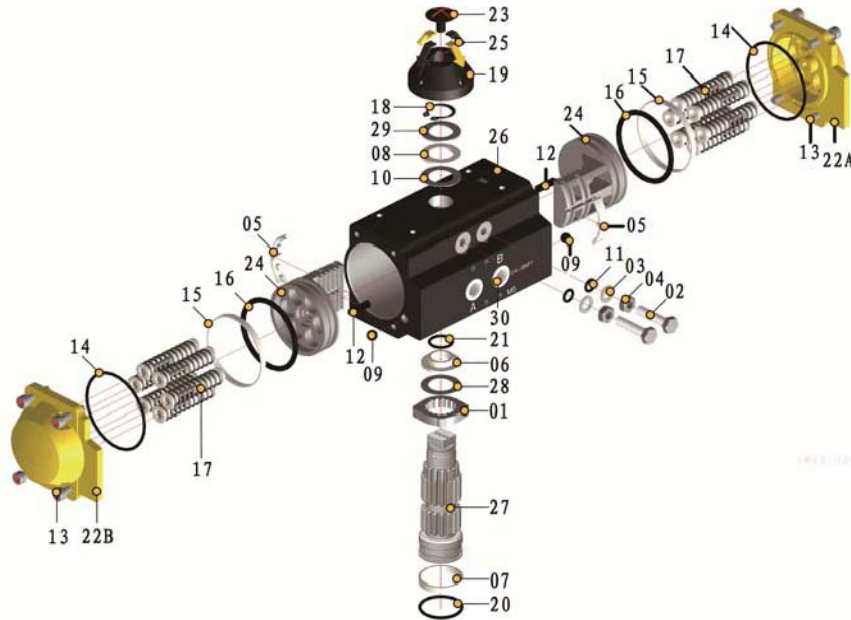

Fig. 16

PART NO.	QTY	PART DESCRIPTION	STANDARD MATERIAL	
01	1	STROKE ADJUSTMENT STOP	Alloy Steel HT200	
02	2	STOP BOLT	Stainless Steel	
03	2	WASHER	Stainless Steel	
04	2	STOP NUT	Stainless Steel	
05*	2	BEARING (Piston back)	Polyphthalamide	
06*	1	BEARING (Pinion top)	Nylon	
07*	1	BEARING (Pinion bottom)	Nylon	
08*	2	THRUST BEARING (Pinion)	Polyphthalamide	
09*	2	PLUG	NBR	Optional: Viton, Silicon
10	1	THRUST WASHER (Pinion)	Stainless Steel 304	
11*	2	"O" RING (Stop nut)	NBR	Optional: Viton, Silicon
12	2	PISTON GUIDE	Polyphthalamide	
13	8	END CAP BOLTS	Stainless Steel 304	
14*	2	"O" RING (End cap)	Buna	Optional: Viton, Silicon
15*	2	BEARING	Polyphthalamide	
16*	2	"O" RING	NBR	Optional: Viton, Silicon
17	5-12	SPRING (Cartridge)	High Alloy Spring Steel	
18	1	SNAP RING	High Alloy Spring Steel	Optional: Stainless Steel
19	1	POSITION INDICATOR	Polypropylene +GF	
20*	1	"O" RING (Pinion bottom)	NBR	Optional: Viton, Silicon
21*	1	"O" RING	NBR	Optional: Viton, Silicon
22A	1	RIGHT END CAP	Die cast Aluminum Alloy	
22B	1	LEFT END CAP	Die cast Aluminum Alloy	
23	1	INDICATOR BOLT	Stainless Steel 304	
24	2	PISTON	Die cast Aluminum Alloy	
25	1	ACTUATOR IDENTIFICATION LABEL	Aluminium	
26	1	BODY	Extruded Aluminum Alloy	
27	1	DRIVE SHAFT	Steel Alloy	Optional: Stainless Steel

*Suggested SPARE PARTS For maintenance

Fig. 17