

Type 3761
Pneumatic or Electropneumatic Positioner
for Rotary Actuators



Fig. 1 · Type 3761 Positioner

Mounting and Operating
Instructions

EB 8386 EN

Edition July 2007



| Contents | Page |
|----------|---------------------------------------------------------------------------|
| 1 | Design and principle of operation 4 |
| 1.1 | Technical data 6 |
| 2 | Attachment to rotary actuators 7 |
| 2.1 | Determining the operating direction 9 |
| 2.2 | Selecting and aligning the cam disc 10 |
| 3 | Connections 13 |
| 3.1 | Pneumatic connections 13 |
| 3.1.1 | Pressure gauges 14 |
| 3.2 | Electrical connections 14 |
| 4 | Operation – Adjustment 16 |
| 4.1 | Starting point and reference variable 16 |
| 4.2 | Adjustment 17 |
| 4.2.1 | Spring-return actuator: valve CLOSED without supply air 17 |
| 4.2.2 | Spring-return actuator: valve OPEN without supply air 18 |
| 4.2.3 | Double-acting actuator: valve opens counterclockwise and clockwise . . 18 |
| 5 | Adjusting the limit switch 20 |
| 6 | Servicing explosion-protected devices 21 |
| 7 | Dimensions in mm 22 |
| | Test certificates 23 |

Note!

Devices with a CE marking fulfil the requirements of the Directives 94/9/EC and 89/336/EEC.

The declaration of conformity can be viewed and downloaded on the Internet at <http://www.samson.de>.



- ▶ *The device is to be assembled, started up or operated only by trained and experienced personnel familiar with the product.
According to these mounting and operating instructions, trained personnel is referred to as individuals who are able to judge the work they are assigned to and recognize possible dangers due to their specialized training, their knowledge and experience as well as their knowledge of the applicable standards.*
- ▶ *Explosion-protected versions of this device are to be operated only by personnel who has undergone special training or instructions or who is authorized to work on explosion-protected devices in hazardous areas.*
- ▶ *Any hazards that could be caused in the control valve by the process medium, the operating pressure or by moving parts are to be prevented by means of the appropriate measures.
If inadmissible motions or forces are produced in the pneumatic actuator as a result of the supply pressure level, it must be restricted using a suitable supply pressure reducing station.*
- ▶ *Proper shipping and storage are assumed.*

| Positioner versions | | Type 3761- | x | x | x | x | x | x |
|------------------------|----------------------------------|------------|---|---|---|---|---|---|
| Explosion protection | Without | 0 | | | | | | |
| | EEx ia IIC T6 | 1 | | | | | | |
| Design | Pneumatic | 1 | 0 | | | | | |
| | Electropneumatic | 2 | | | | | | |
| Tight-closing function | Without | | | | 0 | | | |
| | At a reference variable of 0 % | | | | 1 | | | |
| | At a reference variable of 100 % | | | | 2 | | | |
| Type of function | Single output | | | | | 1 | | |
| | Double output | | | | | 2 | | |
| Accessories | Without electric limit switch | | | | | | 0 | |
| | With electric limit switch | | | | | | 1 | |
| Pneumatic connections | ISO-228/1 – G ¼ | | | | | | | 1 |
| | ¼-18 NPT | | | | | | | 2 |

1 Design and principle of operation

The pneumatic or electropneumatic positioner ensures the assignment of the valve position (controlled variable) to the control signal (reference variable).

The input signal received from a control unit is compared to the control valve's angle of rotation and a corresponding pneumatic signal pressure (output variable) is produced.

The positioner mainly consists of a pneumatic unit including a tension spring (4), diaphragm lever (5) and the amplifier (8) with double plug (7). The electropneumatic positioner is additionally equipped with an electropneumatic converter (10).

Any change of the valve position (controlled variable) is transmitted as a rotary motion of the actuator over the cam disc (2), the pick-up lever (1) and the tension spring (4) to the pneumatic system.

The control signal (positioner's input signal) from the control unit, if it is a pneumatic signal, is applied as a pressure signal p_e directly to the measuring diaphragm (6). A DC input signal e.g. from 4 to 20 mA, is directly passed on to the electropneumatic converter (i/p converter) where it is converted into a proportional pressure signal p_e .

The pressure signal p_e creates a force on the measuring diaphragm (6), which is balanced by the force of the tension spring (4). The movement of the measuring diaphragm is passed on to the double plug (7) of the amplifier (8) through the lever (5) so that a corresponding signal pressure p_{st} is produced.

The positioner's principle of operation is determined by equipping it with either one (single-acting) or two (double-acting) amplifiers.

The operating direction of the signal pressure with increasing \ll or decreasing \llcorner input signal can be changed by relocating the amplifier for single-acting positioners. For double-acting positioners, the signal pressure connections need to be reversed.

Zero is corrected on an adjustment screw. The angle of rotation is determined by the cam disc.

Tight-closing function: For electropneumatic positioners with tight-closing function, the rotary actuator is completely vented or filled with air (depending on the operating direction) as soon as the reference variable falls below or exceeds a given value.

For Type 3761-x21x, the deactivation function is initiated when the switching point of 4.08 mA is not reached. The actuator is completely vented.

For Type 3761-x22x, the activation function is initiated when 19.92 mA are exceeded. The actuator is completely filled with air.

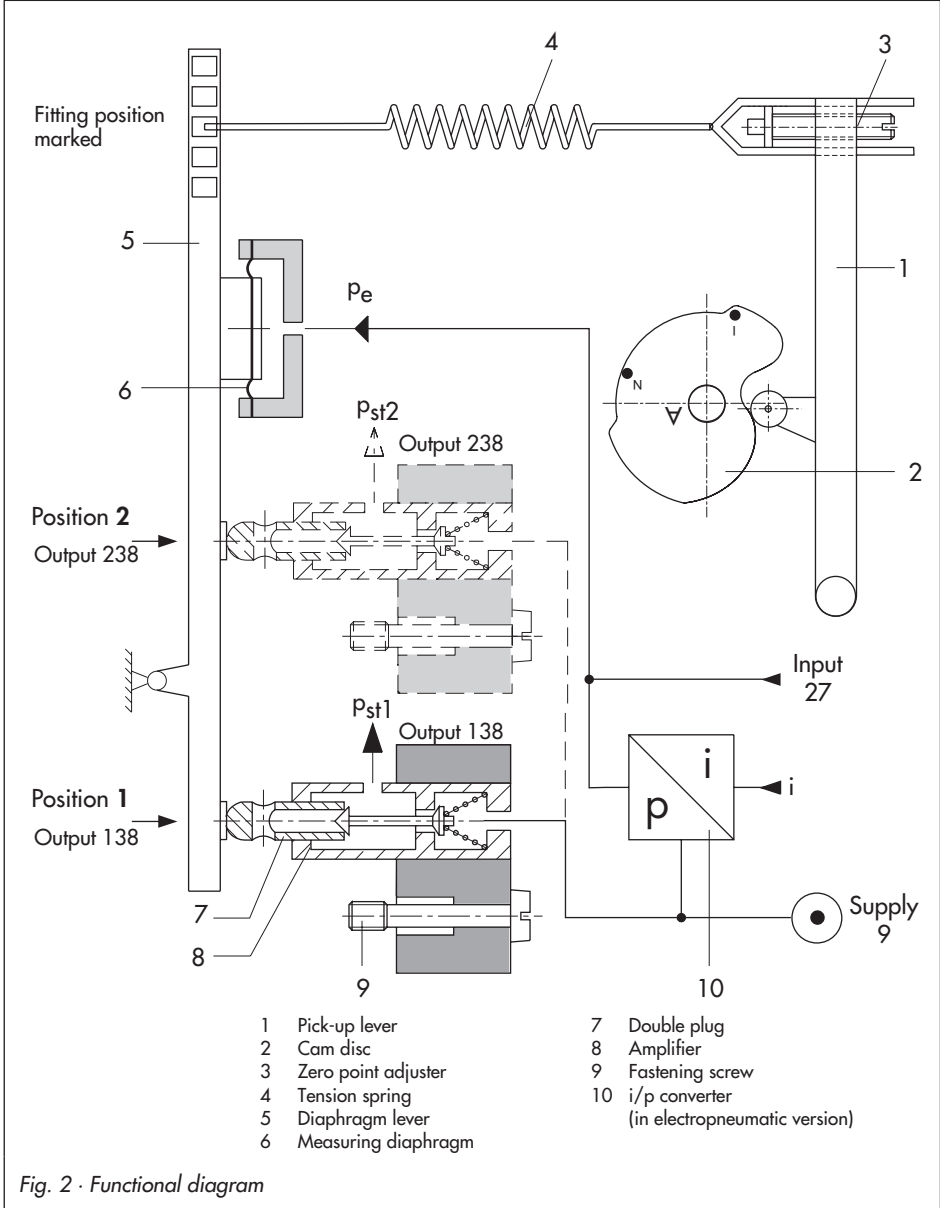

Fig. 2 · Functional diagram

1.1 Technical data

| Type 3761 Positioner | | | |
|---------------------------------------------|------------------------------------|----------------------------------------------------------------------------------------------------------------------------------------------------------------------------------------------------------------------------------------------------------------------------------------------------------|-----------------------------------------------------------------------------------------------------|
| Angle of rotation | | 55° / 70° / 75° / 90° | |
| Reference variable | Electric | 4 to 20 mA (min. 3.6 mA), must be operated on current source Load: 300 Ω at 20 mA (350 Ω at 20 mA with tight-closing function and explosion protection) Reverse polarity protection Static destruction limit 60 mA or 6.4 V (without explosion protection) or 7.6 V (with explosion protection) | |
| | Pneumatic | 0.2 to 1 bar (3 to 15 psi) | |
| Supply air pressure | | 1.4 to 6 bar (20 to 90 psi) | |
| Signal pressure | | 0 to 6 bar (0 to 90 psi) | |
| Characteristic | Cam discs | Linear, deviation from terminal-based conformity ≤ 2 % Standard: 90° linear; others: see table on page 10 | |
| Operating direction | | Reversible | |
| Principle of operation | | Single-acting or double-acting | |
| Hysteresis | | ≤ 1 % | |
| Variable position | | ≤ 7 % | |
| Tight-closing function (can be deactivated) | Type 3761-x21x: Type 3761-x22x: | Deactivated when reference variable ≤ 4.08 mA Activated when reference variable ≥ 19.92 mA | |
| Air consumption in steady state | | Supply air | 1.4 bar 6 bar |
| | | Single-acting Double-acting | 80 l _n /h 200 l _n /h 150 l _n /h 350 l _n /h |
| Air supply | | 3000 l _n /h at 2 bar 6000 l _n /h at 6 bar | |
| Permissible ambient temperature | | -20 to +70 °C, -30 to +70 °C with metal cable entry For explosion-protected versions, the specifications in the declaration of conformity apply additionally | |
| Degree of protection | | IP 54 (optionally IP 65) | |
| Weight | | Approx. 0.9 kg | |
| Electrical accessories (optional) | | Electric limit switch (microswitch with gold-plated contact, SPDT), 250 V AC, 3 A | |

2 Attachment to rotary actuators

| Accessories | | Order no. |
|--------------------------------------------------------------------------------------------------------------------------|---------------------|-----------|
| VDI/VDE 3845, level 1 mounting kit Additionally, a bracket (2) included in the actuator's scope of supply is required | | 1400-7595 |
| Mounting kit for SAMSON Type 3278 including bracket | 160 cm ² | 1400-7615 |
| | 320 cm ² | 1400-7616 |

The mounting kit consists of a follower plate, coupling wheel, scale plate and coupling lever as well as a hose clamp and clamping screw. For SAMSON Type 3278 Rotary Actuators, mount the spacer delivered with the actuator to the free shaft end of the rotary actuator.

1. Fasten mounting bracket (2) to the positioner using 4 screws (2.1).
2. Push follower plate (5) onto the slotted actuator shaft or the spacer (7).
3. Push coupling wheel (4) with its flat side facing towards the actuator onto the follower plate (5). Make sure to position the oblong hole of the coupling wheel such that the clamping screw (3.1) of the coupling lever (3) can easily be accessed when the valve is in closed position.
4. Firmly fasten coupling wheel and follower plate to the actuator shaft using the pan head screw (6) and disc spring (6.1).

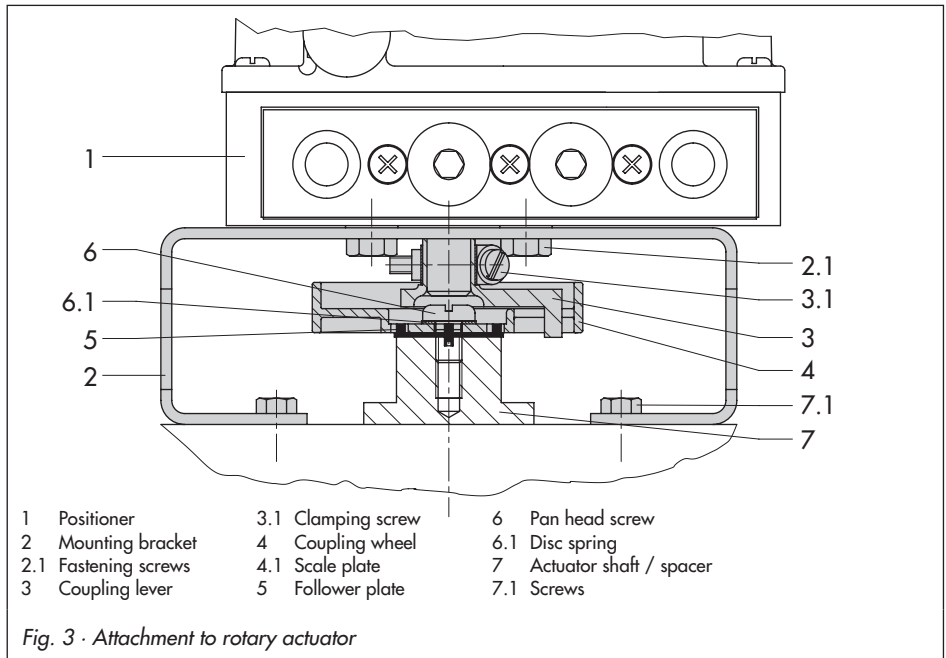

5. Place coupling lever (3) including hose clamp and clamping screw (3.1) loosely onto the coupling wheel (4) so that its contact stud slides into the oblong hole (3.2).
6. Carefully place positioner with mounting bracket (2) onto the rotary actuator. Make sure the positioner axis slides into the coupling lever (3). Observe direction for arranging the connections.
7. Screw the mounting bracket (2) to the actuator using four screws (7.1).
8. Fix scale plate (4.1) to the coupling wheel so that the arrow tip indicates closed position and can easily be identified when the valve is installed (see Fig. 4).
9. Leave the coupling lever, which is fastened with the clamping screw (3.1), loosened at first. Align the cam disc (see section 2.2, page 10). Clamp the lever onto the positioner axis.

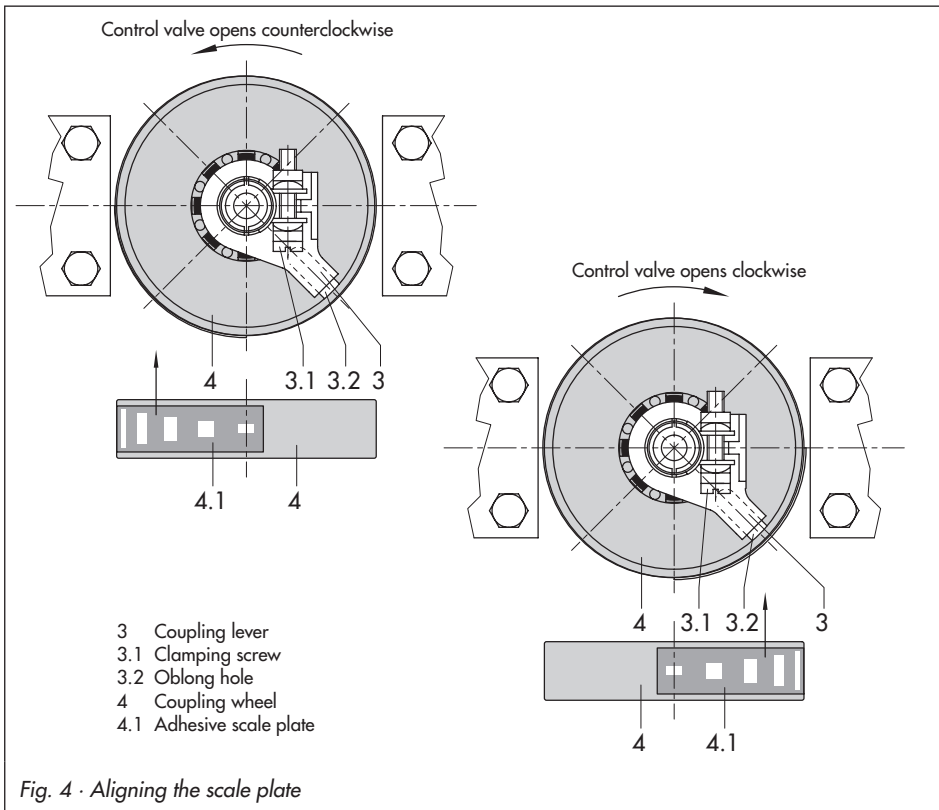

2.1 Determining the operating direction

Important!

The positioner with either single-acting or double-acting output is fixed and cannot be changed by subsequently adding or removing an amplifier.

Single-acting positioners:

The operating direction of the positioner is determined by the mounting position of the amplifier. When the input signal (reference variable) increases, the signal pressure p_{st} can either increase (direct operating direction) or decrease (reverse operating direction).

The same applies when the input signal decreases. For direct operating direction, the signal pressure decreases whereas it increases for reverse operating direction.

For direct operating direction, screw the amplifier in mounting position **1** (Fig. 2); for reverse operating direction, screw the amplifier in mounting position **2**. Screw the cover plate onto the unoccupied position so that the associated supply air bore is sealed.

Note!

When relocating the amplifiers, make absolutely sure that both O-rings remain in the base of the housing.

Double-acting positioners:

The operating direction is determined by the assignment of the signal pressure outputs **138** and **238** to the two connections (y_1 and y_2) of the rotary actuator.

Note!

The designation of the signal pressure connections on the rotary actuator varies depending on the manufacturer.

In Figs. 5 and 6, y_1 and y_2 have been assigned the following functions:

Single-acting actuator

Increasing the signal pressure at y_1 opens the valve if the closure member rotates counterclockwise.

Double-acting actuator

Increasing the signal pressure at y_1 and decreasing the pressure at y_2 opens the valve if the closure member rotates counterclockwise; or

increasing the signal pressure at y_2 and decreasing the pressure at y_1 opens the valve if the closure member rotates clockwise.

2.2 Selecting and aligning the cam disc

The positioner is delivered with a 90° linear cam disc. If a different control characteristic is required, replace the existing cam disc with a cam disc listed in the table below. The default setting of the cam disc depends on the valve design (butterfly valve, ball valve, etc.) and rotary actuator version used. For proper assignment refer to Figs. 5 and 6.

Fig. 5 shows how to adjust the cam disc for control valves with rotary actuators that are equipped with spring-return mechanism. The fail-safe action "valve CLOSED" or "valve OPEN" without supply pressure is determined by how the actuator is attached to the valve.

For example, SAMSON's Type 3278 Actuator can be mounted on a butterfly valve with the shaft attached to either the left or the right actuator flange.

Fig. 6 shows how to adjust the cam disc when a double-acting, springless rotary actuator is used. The direction of rotation, either counterclockwise or clockwise (looking from the positioner onto the actuator shaft), depends on how the rotary actuator is mounted on the valve and how the two signal pressure outputs 138 and 238 are assigned to the connections y1 and y2 of the rotary actuator.

Depending on the rotary actuator's direction of rotation (counterclockwise or clockwise), the starting point of the cam section that must be passed through is either on the front **A** or the back **B** of the cam disc.

| Cam discs | Order no. |
|-------------------------------------------------------------------------------------|-----------|
| Linear cam disc, 90° | 0050-0093 |
| Equal percentage cam disc, 90° | 0050-0095 |
| Linear cam disc, 70° for butterfly valves | 0050-0108 |
| Equal percentage cam disc, 70° for butterfly valves | 0050-0110 |
| Linear cam disc, 75° for VETEC rotary plug valves | 0050-0102 |
| Equal percentage cam disc, 75° for VETEC rotary plug valves | 0050-0104 |
| Linear cam disc, 90° for Type 3310 Segmented Ball Valves | 0050-0114 |
| Equal percentage cam disc, 90° for Type 3310 Segmented Ball Valves | 0050-0116 |
| Linear cam disc, 70° for Type 3310 Segmented Ball Valves with reverse flow | 0050-0126 |
| Equal percentage cam disc, 70° for Type 3310 Segmented Ball Valve with reverse flow | 0050-0128 |
| Linear cam disc, 55° for Type 3310 Segmented Ball Valve with reduced opening angle | 0050-0118 |
| Equal percentage cam disc, 55° for Type 3310 with reduced opening angle | 0050-0120 |

Single-acting actuator with spring return mechanism
Valve opens counterclockwise, linear cam disc (standard)

Fail-safe position "valve CLOSED" without supply pressure
Orientation of cam disc when control valve is closed

| Direct operating direction | | | | Reverse operating direction | | | |
|----------------------------|-----------------|-------|----------|-----------------------------|-----------------|-------|----------|
| Connection: Output 138 | | | | Connection: Output 238 | | | |
| Ref. variable | Signal pressure | Valve | Cam | Ref. variable | Signal pressure | Valve | Cam |
| Increases | Increases | Opens | A | Decreases | Increases | Opens | B |

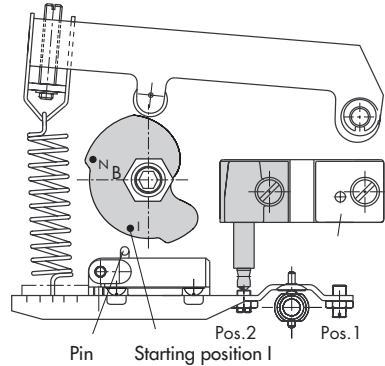
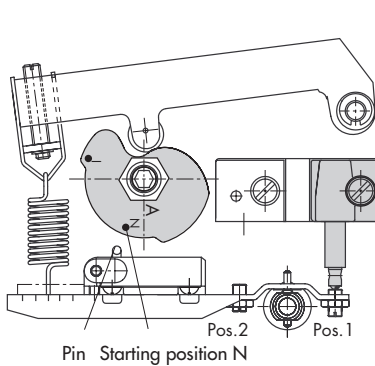

Fail-safe position "valve OPEN" without supply pressure

Orientation of cam disc when control valve is closed, additionally apply max. signal press. to actuator

| Direct operating direction | | | | Reverse operating direction | | | |
|----------------------------|-----------------|-------|----------|-----------------------------|-----------------|-------|----------|
| Connection: Output 138 | | | | Connection: Output 238 | | | |
| Ref. variable | Signal pressure | Valve | Cam | Ref. variable | Signal pressure | Valve | Cam |
| Decreases | Decreases | Opens | B | Increases | Decreases | Opens | A |

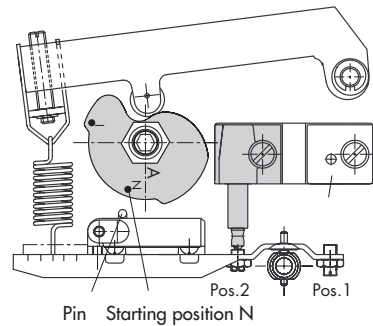
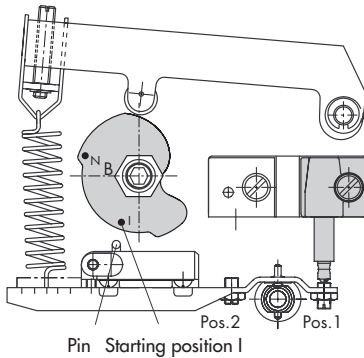

Fig. 5 · Aligning the cam disc for single-acting rotary actuators with spring return mechanism

Double-acting actuator with spring return mechanism

Linear cam disc (standard)

Orientation of cam disc when control valve is closed, additionally apply max. signal press. to actuator

Control valve opens counterclockwise (increasing pressure to y1, decreasing pressure to y2)

| Direct operating direction | | | | Reverse operating direction | | | |
|----------------------------|--------------------------------------|-------|----------|-----------------------------|--------------------------------------|-------|----------|
| Ref. variable | Signal pressure | Valve | Cam | Ref. variable | Signal pressure | Valve | Cam |
| Increases | Output 138 to y1 Output 238 to y2 | Opens | A | Decreases | Output 138 to y2 Output 238 to y1 | Opens | B |

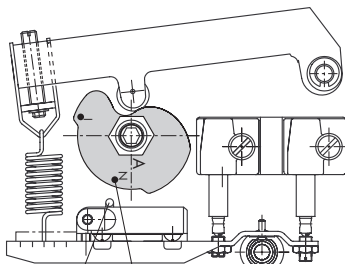

Pin Starting position N

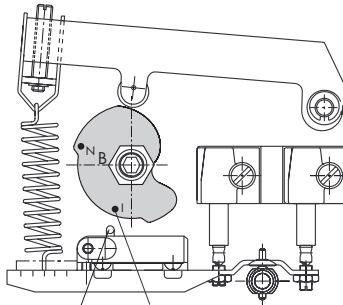

Pin Starting position I

Control valve opens clockwise (increasing pressure to y2, decreasing pressure to y1)

| Direct operating direction | | | | Reverse operating direction | | | |
|----------------------------|--------------------------------------|-------|----------|-----------------------------|--------------------------------------|-------|----------|
| Ref. variable | Signal pressure | Valve | Cam | Ref. variable | Signal pressure | Valve | Cam |
| Increases | Output 138 to y2 Output 238 to y1 | Opens | B | Decreases | Output 138 to y1 Output 238 to y2 | Opens | A |

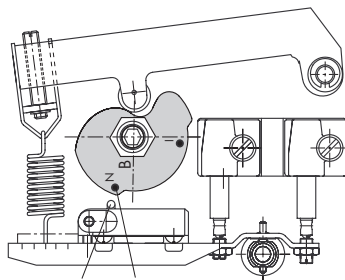

Pin Starting position N

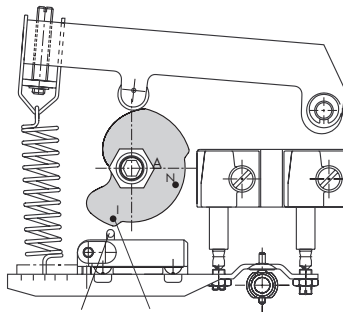

Pin Starting position I

Fig. 6 · Aligning the cam disc for double-acting rotary actuators

Aligning the cam disc:

Important!

Close the control valve before aligning the cam disc as illustrated in Figs. 5 and 6. For actuators with fail-safe action "valve OPEN" without supply pressure and for springless actuators, apply the max. signal pressure to the actuator before aligning the cam disc so that the valve is moved to closed position.

- ▶ Slightly loosen clamping screw (3.1, Fig. 4) so that the cam disc can be rotated together with the positioner shaft.
- ▶ Turn cam disc with the selected cam (**A** or **B**) so that the fulcrum of the cam disc, the marking point and the black pin form a line (Figs. 5 and 6).
- ▶ Hold cam disc in place and tighten clamping screw (3.1).

To flip the cam disc over, insert an Allen key into the positioner shaft to hold it stationary. Loosen the fastening nut and remove the cam disc.

Turn the cam disc over and remount it.

The default setup is shown in the top left of Figs. 5 and 6 (valve closed in fail-safe position, opens counterclockwise and closes clockwise).

3 Connections

3.1 Pneumatic connections

Depending on the cover plate, the pneumatic connections are either ¼-18 NPT or ISO 228/1- G ¼ tapped holes.

The supply input (Supply 9) is fitted with a sintered metal filter (order no. 1400-6897). The other connections are fitted with filters (order no. 0550-0213) to prevent dirt from collecting in the device. Remove the cover plate to clean or replace the filters, if necessary.

Commonly available male connections for metal and copper pipes or plastic hoses can be used for connection.

Caution!

The supply air must be dry and free of oil or dust. Always observe the maintenance instructions of upstream pressure reducing stations. Thoroughly purge all pneumatic lines before connecting them.

Important!

Adjust the supply pressure to 0.2 bar above the upper bench range value of the actuator (see nameplate).

3.1.1 Pressure gauges

To control the supply air (Supply) and signal pressure (Output), pressure gauges as well as a gauge mounting block are required. Replace the included connecting plate with the gauge mounting block.

| Accessories | Order no. |
|-----------------------------------------------------------------------------------------------------------------------|------------------------|
| Gauge mounting block: G 1/4 1/4 NPT | 1400-7611 1400-7612 |
| Pressure gauge (st. steel/brass): 1x supply, 1x output for single-acting 1x supply, 2x output for double-acting | 1400-6950 1400-7613 |

3.2 Electrical connections

Electropneumatic positioner

Connect the wires for the reference variable to terminals +11 and -12 using the housing's cable glands.

For versions with limit switch, additionally connect the limit switch wires to terminals 41, 42 and 43.



For electrical installation, you are required to observe the relevant electrotechnical regulations and the accident prevention regulations that apply in the country of use. In Germany, these are the VDE regulations and the accident prevention regulations of the employers' liability insurance.

The following regulations apply to installation in hazardous areas: EN 60079-14:2003; VDE 0165 Part 1:1998.

The data specified in the certificate of conformity and the EC type examination certificate apply to the connection of intrinsically safe circuits.

Warning!

Switching the assignment of the electrical terminals for the control signal and the limit switch may cause the explosion protection to become ineffective!

Do not loosen enameled screws in or on the housing.

Note on selecting cables and wires

To run several intrinsically safe circuits in one multi-core cable, observe section 12 of EN 60079-14 and VDE 0165, Part 1.

Note especially that, for commonly used insulating materials, such as polyethylene, the radial thickness of the conductor insulation must be at least 0.2 mm. The diameter of a single wire of a flexible conductor must not be smaller than 0.1 mm.

The conductor ends must be protected against unlaying, e.g. by using wire-end ferrules.

When two separate cables are used for connection, an additional cable gland can be installed.

Cable entries left unused must be sealed with plugs.

| Accessories | Order no. |
|---------------------------------------------------------------------------------------|------------------------|
| M20x1.5 cable gland | |
| Black | 1400-6985 |
| Blue | 1400-6986 |
| Metal cable gland for temperatures below -20 °C | 1890-4875 |
| M20x1.5 to ½ NPT adapter Powder-coated aluminum | 0310-2149 |
| Plug connector acc. to DIN 43650 For the reference variable For the microswitch | 1400-7603 1400-7604 |
| Limit switch (retrofit kit) | 1400-7602 |
| Conversion kit to IP 65 | 1790-7408 |

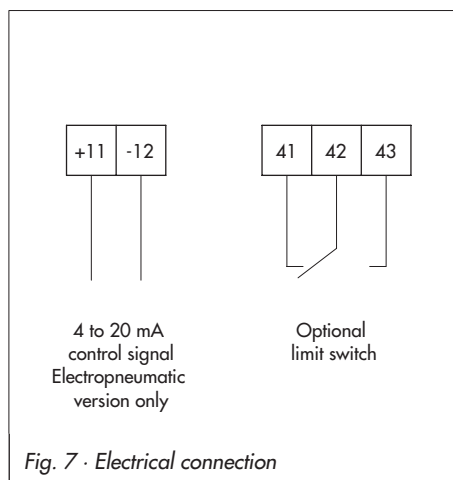

4 Operation – Adjustment

4.1 Starting point and reference variable

Note!

The positioner is delivered with the default settings adjusted by the manufacturer. The pre-determined fitting position of the tension spring (4) is marked by a dot of paint and should not be changed.

If the reference variable is, e.g. 4 to 20 mA (0.2 to 1 bar), the angle of rotation for opening or closing the valve determined by the cam disc causes the valve to travel through its full range.

The starting point is 4 mA (0.2 bar); the upper range value is 20 mA (1 bar).

Note!

Zero adjustment is always based on the valve's closed position. As a result, zero adjustment depends on the actuator version used, e.g. for an actuator with reverse operating direction, zero must be set to 20 mA (1 bar) instead of 4 mA (0.2 bar).

The exact **starting point** is adjusted using the zero adjuster (3; Fig. 2).

The **upper range value** is automatically determined by the cam disc's angle of rotation. If it should be necessary to correct the upper range value, only slight changes can be made using the potentiometer span of the electropneumatic positioner. Turn the potentiometer counterclockwise to reduce the span and clockwise to increase it.

Note!

Electropneumatic positioners with tight-closing function are equipped with a slide switch on the printed input circuit board to activate or deactivate the function.

Important!

Switch off the activation/deactivation function while adjusting zero. Do not activate the relevant function on the switch before zero has been adjusted.

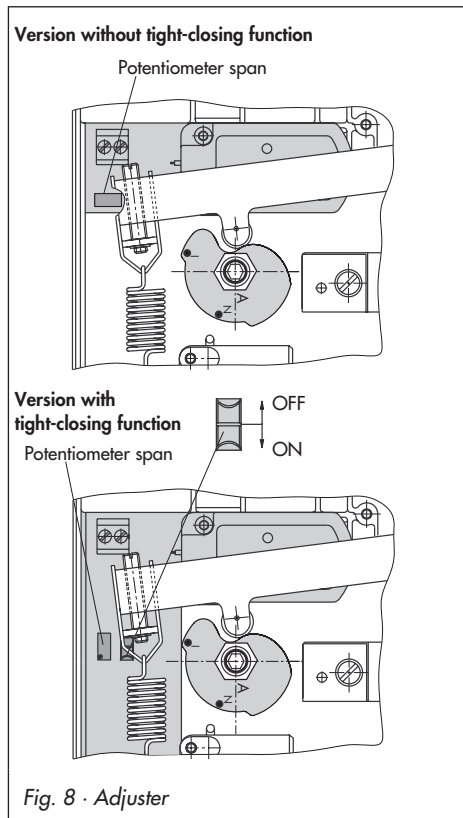

Fig. 8 · Adjuster

Connection

- ▶ For electropneumatic positioners, connect an ammeter to terminals +11 and –12.
- ▶ For pneumatic positioners, connect control signal input (Input 27) to a compressed air source providing max. 1.4 bar using a pressure transducer and pressure gauge.
- ▶ Apply compressed air to the supply input (Supply 9).

4.2 Adjustment

4.2.1 Spring-return actuator: valve CLOSED without supply air

Important!

To ensure that the full closing force can be effective in the control valve, the actuator must be completely vented when either the lower (direct operating direction) or upper (reverse operating direction) range value of the reference variable is reached.

As a result, set the input signal to a slightly higher starting point of 4.5 mA (0.225 bar) for direct operating direction and to a slightly lower starting point of 19.5 mA (0.975 bar) for reverse operating direction. This applies in particular to controllers and control systems whose output signal is limited to 4 to 20 mA.

For electropneumatic positioners with tight-closing function, the starting point and upper range value can be set to 4 or 20 mA. The activation/deactivation function ensures that the valve's closed position is reached.

Example:

With direct operating direction, the control valve is expected to travel through an angle of rotation of 90° (90° cam disc must be installed) with a reference variable of 4 to 20 mA (0.2 to 1 bar).

The valve opens when the reference variable increases.

Starting point (zero) 4 mA (0.2 bar)

1. Set input signal to 4.5 mA using the ammeter or set the pressure adjuster to 0.225 bar.
 2. Turn zero adjuster (3) until the closure member of the valve just starts to move from its rest position.
 3. Switch off the input signal and slowly increase it again. Check whether the closure member starts to move at 4.5 mA (0.225 bar).
 4. Correct any deviations by turning the zero adjuster (3).
-

Note on adjustment with reverse operating direction

With reverse operating direction (Fig. 5, top right), set the starting point (valve CLOSED) to 20 mA (1 bar). The upper range value (valve OPEN) will then be 4 mA (0.2 bar)

4.2.2 Spring-return actuator: valve OPEN without supply air

Note!

For this fail-safe action, a signal pressure that is high enough to tightly close the valve regardless of the plant's upstream pressure must be applied to the actuator at the upper range value of the reference variable (20 mA or 1 bar) for direct operating direction and at the lower range value of the reference variable (4 mA or 0.2 bar) for reverse operating direction.

The required signal pressure should be approx. 1 bar above the upper bench range value of the actuator.

Example:

With direct operating direction, the control valve is expected to travel through a rotational angle of 90° (90° cam disc must be installed) with a reference variable of 4 to 20 mA (0.2 to 1 bar).

The valve closes when the reference variable increases.

Starting point (zero) 20 mA (1 bar)

1. Set input signal to 20 mA using the ammeter or set the pressure adjuster to 1 bar.
2. Turn zero adjuster (3) until the closure member of the valve just starts to move from its initial position.
3. Increase the input signal and slowly reduce it again. Check whether the closure member starts to move at 20 mA (1 bar).
4. Correct any deviations by turning the zero adjuster (3).

Note on adjustment with reverse operating direction

With reverse operating direction (Fig. 5, bottom right), set the starting point (valve CLOSED) to 4.5 mA (0.225 bar). The upper range value (valve OPEN) will then be 20 mA (1 bar)

4.2.3 Double-acting actuator: valve opens counterclockwise and clockwise

Example:

With direct operating direction, the control valve is expected to travel through a rotational angle of 90° (90° cam disc must be installed) with a reference variable of 4 to 20 mA (0.2 to 1 bar).

The valve opens when the reference variable increases.

Starting point (zero) 4 mA (0.2 bar)

1. Set input signal to 4.5 mA using the ammeter or set the pressure adjuster to 0.2 bar.
2. Turn zero adjuster (3) until the closure member of the valve just starts to move from its rest position.
3. Switch off the input signal and slowly increase it again. Check whether the closure member starts to move at 4.5 mA (0.225 bar).
4. Correct any deviations by turning the zero adjuster (3).

Note on adjustment with reverse operating direction

With reverse operating direction (Fig. 6, right), set the starting point (valve CLOSED) to 19.5 mA (0.975 bar). The upper range value (valve OPEN) will then be 4 mA (0.2 bar).

Important!

After adjusting the positioner, close it by re-mounting the cover. Make sure that the vent plug in the housing points down when the control valve is installed in the plant. This helps prevent condensed water from collecting in the positioner.

5 Adjusting the limit switch

Versions equipped with a limit switch can issue signals to indicate the travel end positions.

The rotary motion of the closure member is transmitted to the limit switch over the actuator, positioner shaft and cam disc (1).

The limit switch can be adjusted to issue a signal when the valve has reached either of its end positions, i.e. OPEN or CLOSED position.

Adjusting the switching point:

Adjust the starting point and upper range value before adjusting the limit switch.

1. Adjust the reference variable so that the valve moves to the desired end position where the switching function is to be activated.
2. Loosen screw (3) and turn plate (2) so that the roll (4) of the limit switch (5) triggers the switching contact at the respective cam (1.1) of the cam disc.
3. Tighten screw (3) and check switching point again.

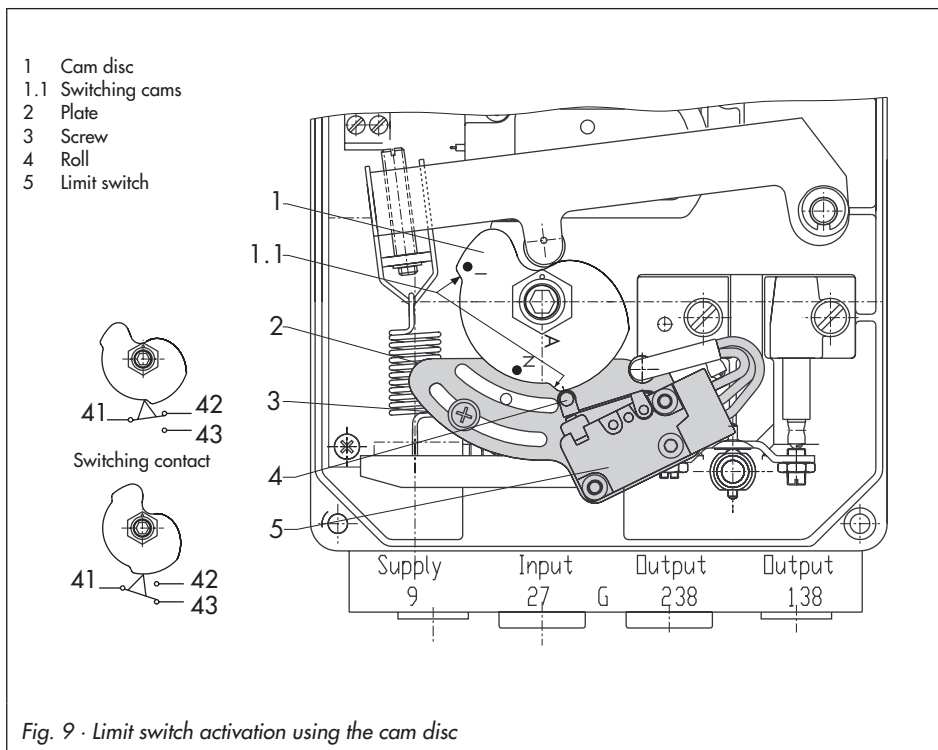

Fig. 9 · Limit switch activation using the cam disc

6 Servicing explosion-protected devices

If a part of the positioner on which the explosion protection is based needs to be serviced, the positioner must not be put back into operation until an expert has inspected it according to explosion protection requirements, has issued a certificate stating this or given the device a mark of conformity.

Inspection by an expert is not required if the manufacturer performs a routine test on the device prior to putting it back into operation. The passing of the routine test must be documented by attaching a mark of conformity to the device.

Explosion-protected components may only be replaced by original, routine-tested components from the manufacturer.

7 Dimensions in mm

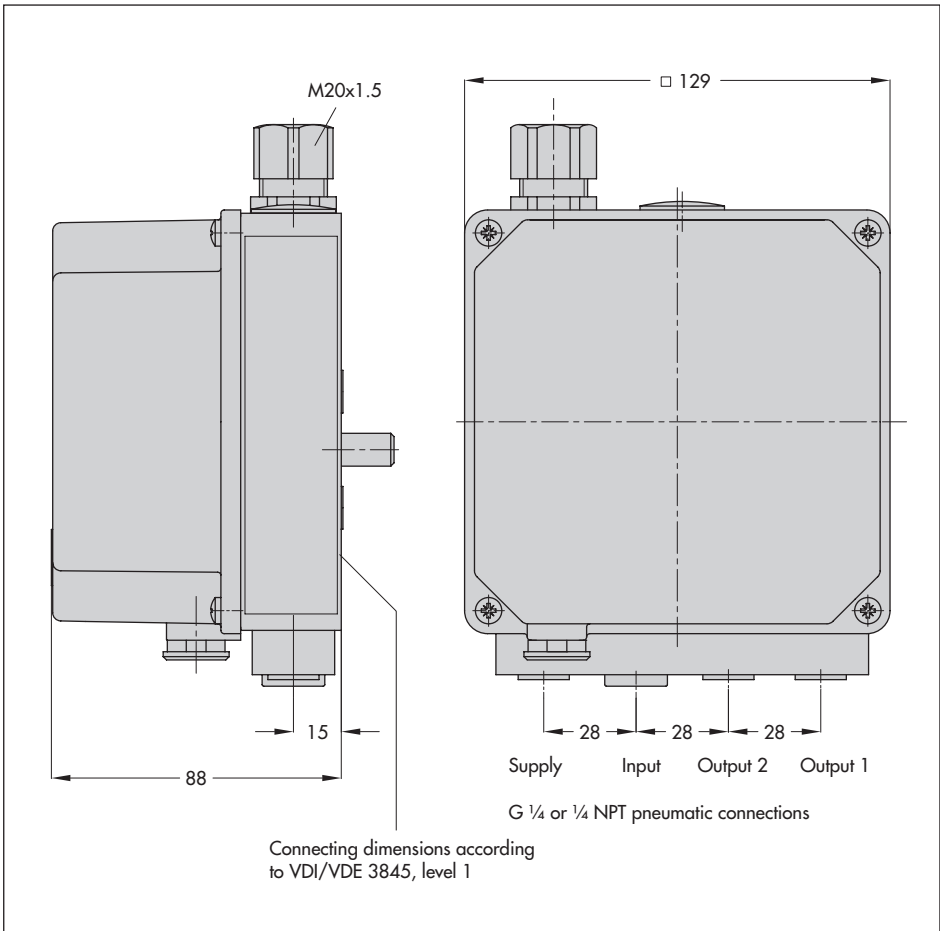



TRANSLATION

EC TYPE EXAMINATION CERTIFICATION

(1) Equipment and Protective Systems Intended for Use in Potentially Explosive Atmospheres – **Directive 94/9/EC**

(2) EC Type Examination Certificate Number

PTB 00 ATEX 2159

(3) Equipment: Medel „3761-1..“

(4) Manufacturer: SAMSON AG

(5) Address: Weismüllerstr. 3, D-60314 Frankfurt

(6) This equipment and any acceptable variation thereof are specified in the schedule to this certificate and the documents referred to therein.

(7) The Physikalisch-technische Bundesanstalt, certified body number 0102 in accordance with Article 9 of the Council Directive 94/9/EC of 23 March 1994, certifies that this equipment has been found to comply with the Essential Health and Safety Requirements of the Council Directive 94/9/EC and the applicable technical protective systems intended for use in potentially explosive atmospheres given in Annex II to the Directive.

The examination and test results are recorded in confidential report.

(8) Compliance with the Essential Health and Safety Requirements has been assured by compliance with

EN 50014: 1997 +A1 + A2 EN 50020: 1994

(9) If the sign 'X' is placed after the certificate number, it indicates that the equipment is subject to special conditions for safe use specified in this schedule to this certificate.

(10) According to the Directive 94/9/EC, this EC TYPE EXAMINATION CERTIFICATE relates only to the design and construction of the specified equipment. If applicable, further requirements of this Directive apply to the manufacture and supply of the equipment.

This EC Type Examination Certificate may only be reproduced in its entirety and without any changes, suitable included. Changes to the original copy are prohibited. www.ptb.de

Physikalisch-technische Bundesanstalt, Bundesallee 100, D-38116 Braunschweig PTB24-3761.d0c



(12) The marking of the equipment shall include the following:



Zertifizierungsstelle Explosionschutz Braunschweig,

By order

(Signature) (Seal)

Dr. Ing. U. Johannsmeyer
Regierungsdirektor

This EC Type Examination Certificate may only be reproduced in its entirety and without any changes, suitable included. Changes to the original copy are prohibited. www.ptb.de

Physikalisch-technische Bundesanstalt, Bundesallee 100, D-38116 Braunschweig PTB24-3761.d0c

Physikalisch-Technische Bundesanstalt
Braunschweig und Berlin

PTB

(13) **Schedule**

(14) **EC TYPE EXAMINATION CERTIFICATE No. PTB 00 ATEX 2159**

(15) **Description of Equipment**

The Model 3761-1... Positioner for Rotary Actuators serves for translating control signals into valve stem positions.

The Model 3761-1... Electropneumatic Positioner for Rotary Actuators is a passive two-terminal network which may be connected to any certified intrinsically safe circuit provided the permissible maximum values of U_i and P_i are not exceeded.

The device is intended for use inside and outside of hazardous areas.

The correlation between temperature classification, permissible maximum ambient temperature ranges and maximum short-circuit currents is shown in the table below.

| Temperature class | Permissible ambient temperature range | Maximum short-circuit current |
|-------------------|---------------------------------------|-------------------------------|
| T6 | -40 °C ... 60 °C | 85 mA |
| T5 | -40 °C ... 70 °C | or |
| T4 | -40 °C ... 80 °C | 100 mA |

Electrical data

Power supply

Type of protection: Intrinsic Safety EEx ia IIC
only for connection to a certified intrinsically safe circuit

Maximum values:

U_i = 28 V

I_i = 100 mA or 85 mA resp.

P_i = 0.7 W

C_i = negligible, L_i = negligible

(16) **Report PTB Ex 00 - 20150**

EC Type Examination Certificate without signature and seal are invalid.
This EC Type Examination Certificate may only be reproduced in its entirety and without any changes, schedule included.
Errors or changes shall require the prior approval of the Physikalisch-Technische Bundesanstalt.

Physikalisch-Technische Bundesanstalt - Bundesallee 100, D-38116 Braunschweig PTB24-3761.doc

Physikalisch-Technische Bundesanstalt
Braunschweig und Berlin

PTB

(17) **Special conditions for safe use**

Not applicable

(18) **Essential Health and Safety Requirements**

In compliance with the standards specified above.

Braunschweig, 9 January 2001

Zertifizierungsstelle Explosionschutz
By order

(Signature) (seal)

Dr.-Ing. U. Johannsmeyer
Regierungsrat/direktor

EC Type Examination Certificate without signature and seal are invalid.
This EC Type Examination Certificate may only be reproduced in its entirety and without any changes, schedule included.
Errors or changes shall require the prior approval of the Physikalisch-Technische Bundesanstalt.

Physikalisch-Technische Bundesanstalt - Bundesallee 100, D-38116 Braunschweig PTB24-3761.doc

**TRANSLATION
ADDENDUM No.: 1**

**in compliance with Directive 94/9/EC Annex III Classes 6
to the EC Type Examination Certificate PTB 00 ATEX 2159**

Equipment: 3761-1-1... Positioner for Rotary Actuators

Marking: II 2 G Exr Ia IIC T6

Manufacturer: SAMSON AG

Address: Weismüllerstr. 3, D-60314 Frankfurt

Description of the conditions and modifications

In future the model 3761-1-1... Positioner for Rotary Actuators may be manufactured in compliance with the certification documents identified in the associated test report.

The modifications related to the design and construction.

The electrical data are changed as follows:

Electrical data

Signal circuit
Type of protection: Intrinsic Safety Exr Ia IIC
with connection to a certified intrinsically
safe circuit

Maximum values:

$U_i = 28 \text{ V}$
 $I_i = 0 \text{ mA}$ or 85 mA resp.
 $P_i = 0,7 \text{ W}$

$C_i = 3 \text{ nF}$, $L_i = 48 \text{ } \mu\text{H}$

All the other data apply without change also to this Addendum No. 1.

EC Type Examination Certificate without signature and seal are invalid.
This EC Type Examination Certificate may only be reproduced in its entirety and without any changes, suitable included.
Brauchstempel: Physikalisch-Technische Bundesanstalt, Braunschweig und Berlin

Physikalisch-Technische Bundesanstalt, Bundesallee 100, D-38116 Braunschweig
PTB24-3761.d0c

Test report: **PTB Ex.01.21072**

Zertifizierungsstelle Explosionschutz
By order

(Signature)

(Seal)

Dr.-Ing. U. Johannsmeyer
Regierungsdirektor

(Signature)

(Seal)

Dr.-Ing. U. Johannsmeyer
Regierungsdirektor

Braunschweig, 7 June 2001

EC Type Examination Certificate without signature and seal are invalid.
This EC Type Examination Certificate may only be reproduced in its entirety and without any changes, suitable included.
Brauchstempel: Physikalisch-Technische Bundesanstalt, Braunschweig und Berlin

Physikalisch-Technische Bundesanstalt, Bundesallee 100, D-38116 Braunschweig
PTB24-3761.d0c



**TRANSLATION
ADDENDUM N o. 2**

in compliance with Directive 94/9/EC Annex III Clause 6
to the EC Type Examination Certificate PTB 00 ATEX 2159

Equipment: 3761-1... Positioner for Rotary Actuators

Marking: II 2 G Ex ia IIC T6
Manufacturer: SAMSON AG Mess- und Regeltechnik
Address: Weismüllerstr. 3, D-40314 Frankfurt

Description of the additions and modifications

The Positioner Model 3761-1... will be supplemented by the Models 3761-1.0 (without light shutoff function) and 3761-1.1... (with electric proximity switch) and in future is permitted to be manufactured in compliance with the certification documents identified in the associated test report.

The modifications related to the design and construction.

The correlation between temperature classification, permissible ambient temperature ranges and the maximum short-circuit current is shown in the table below:

Version with I/P Module 6109

| Temperature class | Permissible ambient temperature range | Maximum short-circuit current |
|-------------------|---------------------------------------|-------------------------------|
| T6 | -45 °C... 60 °C | 85 mA |
| T5 | -45 °C... 70 °C | 100 mA |
| T4 | -45 °C... 80 °C | |
| T5 | -45 °C... 70 °C | |
| T4 | -45 °C... 80 °C | |

EC Type Examination Certificate without signature and seal are invalid.
This EC Type Examination Certificate may only be reproduced in its entirety and without any changes, schedule included.
Edits or changes shall require the prior approval of the Physikalisch-Technische Bundesanstalt.

Physikalisch-Technische Bundesanstalt, Bundesallee 100, D-38116 Braunschweig PTB24642-2.doc



Version with I/P Module 6112

| Temperature class | Permissible ambient temperature range | Maximum short-circuit current |
|-------------------|---------------------------------------|---------------------------------|
| T6 | -45 °C... 60 °C | 85 mA or 100 mA or 120 mA |
| T5 | -45 °C... 70 °C | |
| T4 | -45 °C... 80 °C | |

Electrical data

Version with I/P Module 6109

Signal circuit (terminals 11/12)
Type of protection: Intrinsic Safety Ex ia IIC
only for connection to a certified intrinsically safe circuit

Maximum values:

U_i = 28 V
I_i = 100 mA or 85 mA resp.
P_i = 0.7 W
C_i = negligible, U = negligible

Version with I/P Module 6112

Signal circuit (terminals 11/12)
Type of protection: Intrinsic Safety Ex ia IIC
only for connection to a certified intrinsically safe circuit

Maximum values:

U_i = 28 V
I_i = 100 mA or 85 mA resp.
P_i = 0.7 W
C_i = negligible, U = negligible
or
U_i = 25 V
I_i = 120 mA
P_i = 0.7 W
C_i = negligible, U = negligible

EC Type Examination Certificate without signature and seal are invalid.
This EC Type Examination Certificate may only be reproduced in its entirety and without any changes, schedule included.
Edits or changes shall require the prior approval of the Physikalisch-Technische Bundesanstalt.

Physikalisch-Technische Bundesanstalt, Bundesallee 100, D-38116 Braunschweig PTB24642-2.doc

Electric proximity switch

Type of protection: Intrinsic Safety Ex, ia IIC
only for connection to a certified intrinsically
safe circuit

Maximum values:

U_i = 45 V
 P_i = 2 W

Ci = negligible, Li = negligible

Addendum No. 2 to the EC Type Examination Certificate PTB 00 ATEX 2159

All the other data apply to the Addendum No. 2 without change.

Test report: **PTB Ex 03-23336**

Zertifizierungsstelle Explosionschutz
By order

Braunschweig,

(Signature) (Seal)

Dr.-Ing. U. Johannmeyer
Regierungsdirektor

(Signature) (Seal)

Dr.-Ing. U. Johannmeyer
Regierungsdirektor

EC Type Examination Certificates without signature and seal are invalid.
This EC Type Examination Certificate may only be reproduced in its entirety and without any changes, schedules included.
Changes to the signature or the type approval number are prohibited and will be reported to the competent authorities.

Physikalisch-Technische Bundesanstalt, Bundesallee 100, D-38116 Braunschweig P102AMd-2.6oc



SAMSON AG · MESS- UND REGELTECHNIK
Weismüllerstraße 3 · 60314 Frankfurt am Main · Germany
Phone: +49 69 4009-0 · Fax: +49 69 4009-1507
Internet: <http://www.samson.de>

EB 8386 EN

S/Z 2007-07