

NPR4100 Series

Negative Pressure Regulator

aerospace
climate control
electromechanical
filtration
fluid & gas handling
hydraulics
pneumatics
process control
sealing & shielding

Customer Value Proposition:

The NPR4100 Series regulator offers negative delivery pressures with the use of low pressure gas sources. This regulator is specifically designed to regulate negative pressures down to -26 in. Hg vacuum (100 Torr).

Close tolerances and tight alignment of moving components minimize hysteresis and improve cycle life. Convoluted, Hastelloy C-22® diaphragm provides high corrosion resistance and increases cycle life.



Contact Information:

Parker Hannifin Corporation
Veriflo Division
250 Canal Blvd
Richmond, California 94804

phone 510 235 9590
fax 510 232 7396
veriflo.sales@parker.com

www.parker.com/veriflo

Product Features:

- Unique patented compression member loads the seal to the body without requiring a threaded nozzle or additional seals.
- Internally threadless design reduces particle generation. The low internal volume reduces purge times.
- Cleaned for O₂ service is standard.
- Positive upward and downward stops increase cycle life by preventing over stroking of the diaphragm.
- Selection of seat materials for media compatibility and temperature applications.
- Unique carrier design disperses gas uniformly through the regulator to improve purging.



ENGINEERING YOUR SUCCESS.

NPR4100 Series

Flow Curves

Additional configurations available upon request

NPR4100 ($C_v = .06$)
Inlet Pressure - 4 PSIG

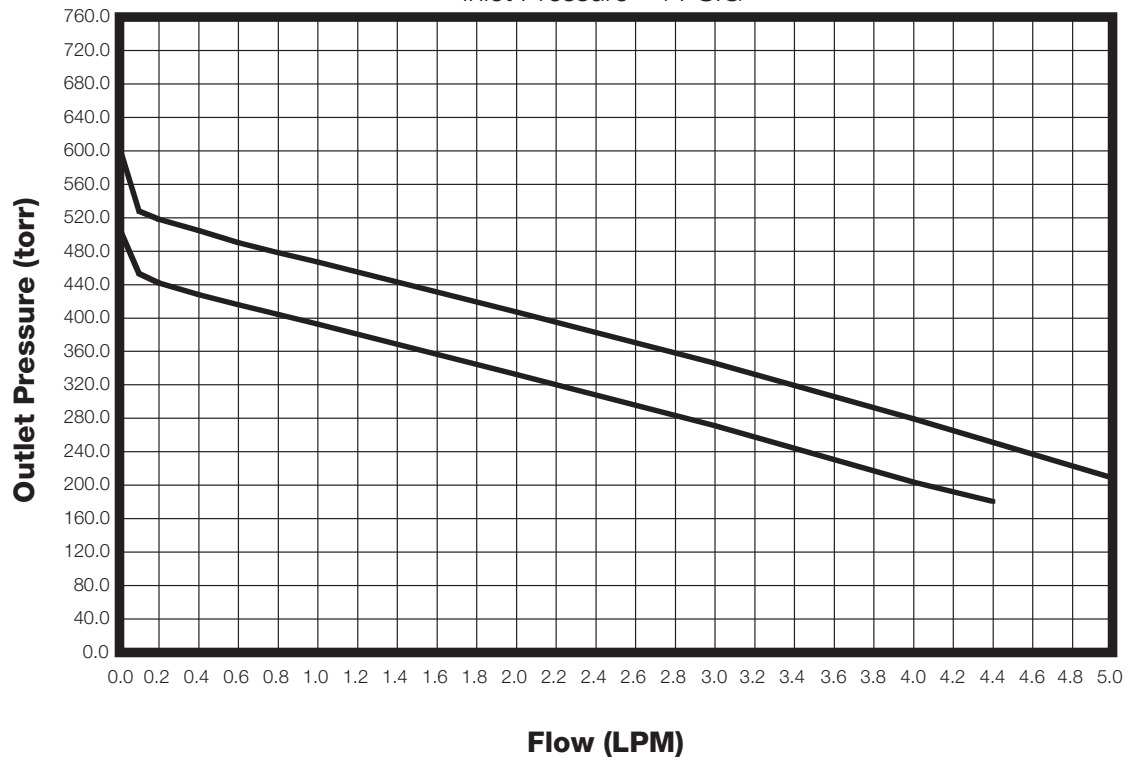

Dimensional Drawing

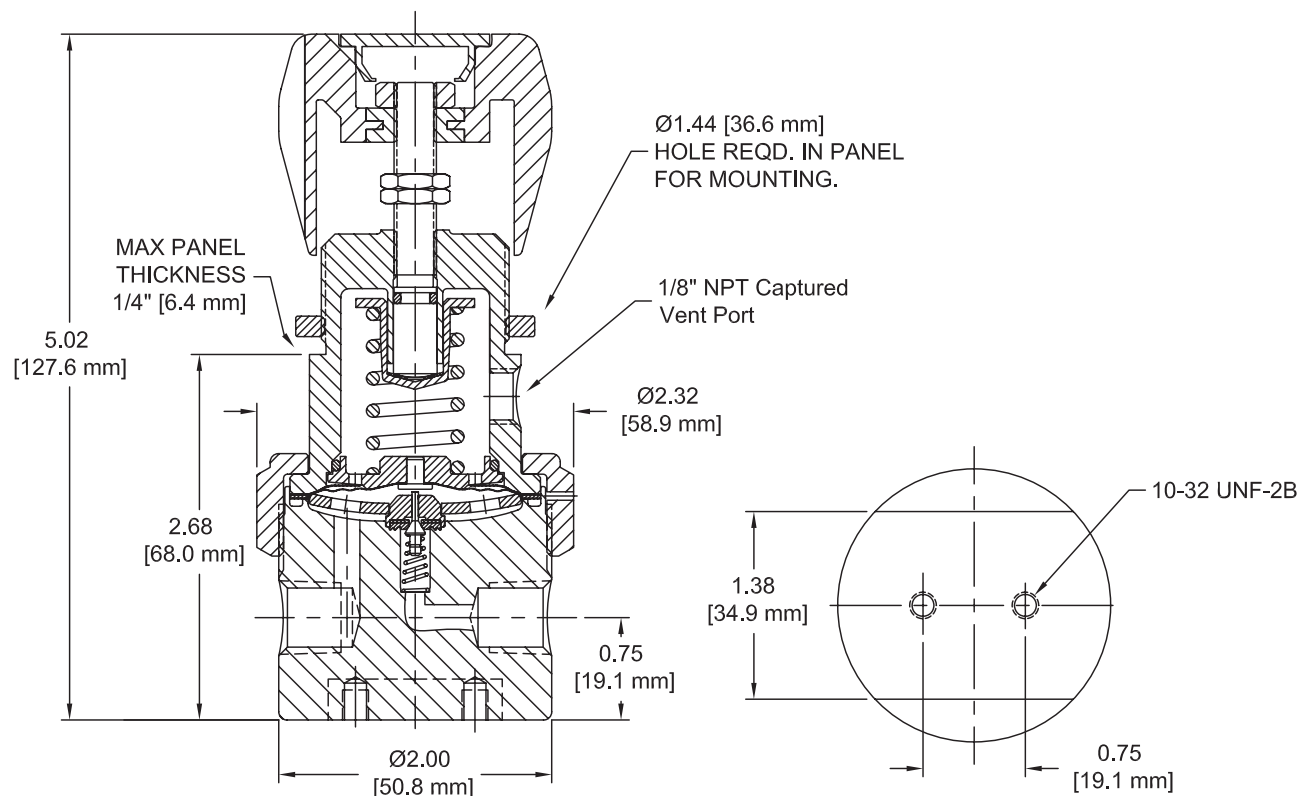

Safety Guide and Installation and Operating Instructions available at
www.parker.com/veriflo

NPR4100 Series

Ordering Information

Build an NPR4100 Series Regulator by replacing the numbered symbols with an option from the corresponding tables below.

Sample: **NPR410**  **0**  **S**  **K**  **4P**  **V3**  **X**  **4**  **B**  **CS**  **CS** 

Finished Order: **NPR4100SK4PV3X4BCS**

 **1 Pressure Range**
0 = -26 in Hg - 10 psig

 **2 Body Material**
S = 316L Stainless Steel
B = Brass
H = Hastelloy C-22®
M = Monel®

 **3 Flow Capacity**
omit = 0.06 Cv (Standard)
1 = 0.02 Cv
2 = 0.15 Cv

 **4 Seat Material**
K = PCTFE
P = PEEK™
V = Vespel® - Recommended for Nitrous Oxide (N2O) Service

 **5 Porting**
2P = 2 Ports - No X required for gauges, Inlet & outlet ports only
3P = 3 Ports - One X for gauge port
4P = 4 Ports - Two X's for gauge ports
4PB = 4 Ports - One X for gauge port

Note:
Ports may be plugged for NPT threaded product.

See Regulator Porting Guide for more information.

 **6 Outlet Gauge**
V3 = -30 in Hg 0 - 30 psig
X = No Gauge

 **7 Inlet Gauge**
V3 = -30 in Hg 0 - 30 psig
V1 = -30 in Hg 0 - 100 psig
2 = 0 - 200 psig
4 = 0 - 400 psig
X = No Gauge

 **8 Port Style**
2 = 1/8" NPT Female
4 = 1/4" NPT Female
6 = 3/8" NPT Female
4T = 1/4" A-LOK®
6T = 3/8" A-LOK®
8T = 1/2" A-LOK®

Note: All Gauge ports are 1/4" NPT Female.

 **9 Port Mounting**
B = 0.75 port height w/0.75 mounting hole pattern

 **10 Optional Features**
This section can have multiple options

B = True Ported Body (no plugs)
C = Corrosion Resistant External (Stainless Steel Cap)
D = Dome Loaded (Not available with G or M options)
G = Tamper Proof (Not available with D or M options)
L = PTFE Backup O-Ring (PTFE and PEEK™ Seats Only)
M = Metal Knob (White) (Not available with D or G options)
N = Nickel Plate (Brass bodies only)
R = Relief Valve (4PB Only)
S = Self Relieving
T = Hastelloy® Trim (Includes carrier and back-up washer. Option is for Stainless Steel body - Hastelloy® Trim is std with Hastelloy® and Monel® bodies)
V = Outlet Valve NOVAS44MF or NOVAB44MF for Brass Body

Note: Panel Mount Option:
Order Panel Nut Ring p/n: 41900363 as a separate line item.

Vent Muffler Option:
Order Vent Muffler p/n: 46600581 as a separate line item.

 **11 CGA#**
320, 330, 350, 510, 580, or 590
Do not exceed the rated pressure of the CGA connection.

NPR4100 Series

Specifications

Materials of Construction	
Wetted	
Body Options	316L Stainless Steel (<i>std</i>), Brass, Hastelloy C-22® and Monel® (<i>Hastelloy® Trim is std with Hastelloy® and Monel® bodies</i>)
Compression Member	Inconel 625®
Diaphragm	Hastelloy C-22®
Diaphragm Pin	Hastelloy C-22®
Poppet	Hastelloy C-276®
Poppet Spring	Inconel X750®
Seat Options	PCTFE, PEEK™ or Vespel®
Carrier Options	316L Stainless Steel (<i>std</i>) or Hastelloy C-22®
Washer Back-up Options	316 Stainless Steel (<i>std</i>) or Hastelloy C-276®
O-ring Back-up Options	FKM (<i>std</i>) or PTFE
Inlet Screen / Filter	316 Stainless Steel (<i>std</i>) (60µm mesh screen, 10µm Filter) Copper and Phosphor Bronze (on Brass bodies), Hastelloy® (on Hastelloy® & Monel® bodies)
Non-wetted	
Cap Options	Nickel Plated Brass (<i>std</i>) Stainless Steel
Nut	Stainless Steel
Knob Options	ABS (<i>std</i>) (ambient temp), Aluminum

Functional Performance	
Design	
Burst Pressure	12,000 psig (828 barg)
Proof Pressure	6,000 psig (414 barg)
Flow Capacity	
C _v Options	C _v 0.06 (<i>std</i>), C _v 0.02, C _v 0.15
Leak Rate	
Internal:	Bubble Tight
External:	Bubble Tight
Internal Volume	4.0 cc without fittings
Approx. Weight	1.5 lbs. (0.7 kg)
Operating Conditions	
Maximum Inlet	250 psig (17 barg)
Outlet Options	100 torr to 10 psig (-26 in Hg to .7 barg)
Temperature	<i>Based upon seat material choice</i>
PCTFE	-40°F to 150°F (-40°C to 66°C)
PEEK™ *	-40°F to 275°F (-40°C to 135°C)
Vespel® *	-40°F to 500°F (-40°C to 260°C)
<i>*Not available for Brass Bodies</i>	

For additional information on materials of construction, functional performance and operating conditions, see Regulator Technical Bulletin.

OFFER OF SALE:

The items described in this document are hereby offered for sale by Parker-Hannifin Corporation, its subsidiaries or its authorized distributors. This offer and its acceptance are governed by the provisions stated in the detailed "Offer of Sale" elsewhere in this document or available at www.parker.com/veriflo

WARNING USER RESPONSIBILITY

FAILURE OR IMPROPER SELECTION OR IMPROPER USE OF THE PRODUCTS DESCRIBED HEREIN OR RELATED ITEMS CAN CAUSE DEATH, PERSONAL INJURY AND PROPERTY DAMAGE. THIS DOCUMENT IS FOR REFERENCE ONLY. PLEASE CONSULT FACTORY FOR LATEST PRODUCT DRAWINGS AND SPECIFICATIONS

This document and other information from Parker-Hannifin Corporation, its subsidiaries and authorized distributors provide product or system options for further investigation by users having technical expertise.

The user, through its own analysis and testing, is solely responsible for making the final selection of the system and components and assuring that all performance, endurance, maintenance, safety and warning requirements of the application are met. The user must analyze all aspects of the application, follow applicable industry standards, and follow the information concerning the product in the current product catalog and in any other materials provided from Parker or its subsidiaries or authorized distributors.

To the extent that Parker or its subsidiaries or authorized distributors provide component or system options based upon data or specifications provided by the user, the user is responsible for determining that such data and specifications are suitable and sufficient for all applications and reasonably foreseeable uses of the components or systems.