

Mass Emission Qualified by Independent Laboratory to EPA Testing Procedures (See Page 2)

An ISO 9001 Registered Company

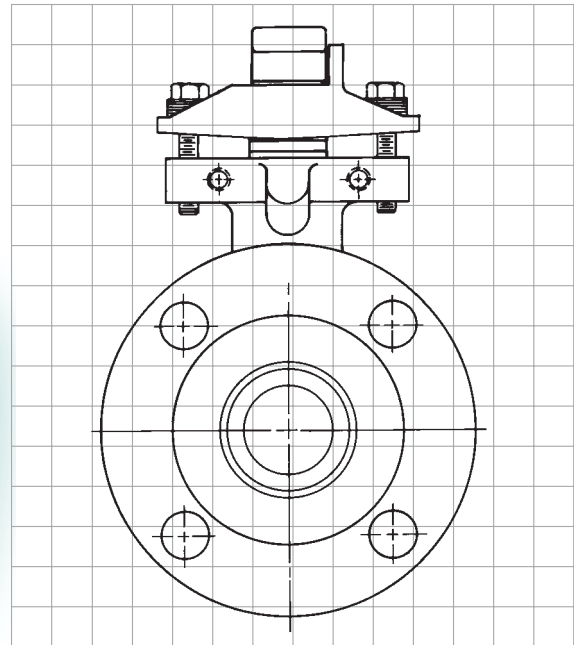

Series 94, 94-150, 94-300 and 94-600

*The High-Performance Solution
For Fugitive Emission, Toxic Gas
Or High-Cycle Applications*

The Series 94

Series 94 (Three-Piece) • Series 94-150/300 (Flanged) • Series 94-600 (Flanged)

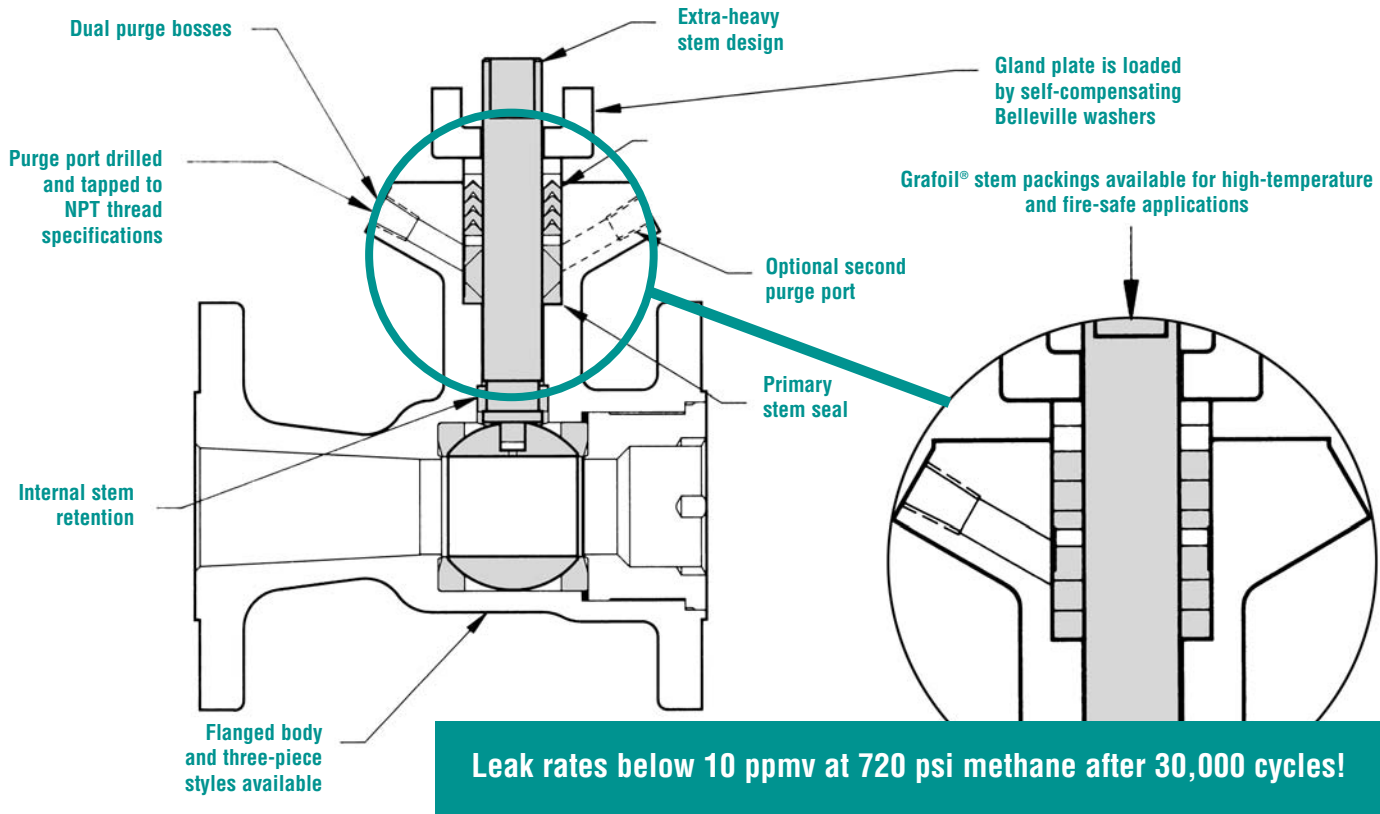

Worcester’s Series 94 valve sets new performance standards for both cycle-life and leak tightness of ball valves. Available in flanged body or three-piece styles, it offers a unique combination of features:

- Dual Stem Seals – A primary seal and filler ring seal against the stem and body. Three chevron-style packing rings, loaded by the gland plate, form the secondary seal.
- Double “Live-loaded” Stem Seals – Stem seals benefit from the spring-like properties inherent in the chevron-style rings. They are further loaded by the gland plate that is under constant force from the stacked Belleville washers.
- Two Stem Purge Bosses – The Series 94 comes with two bosses in the stem area. One is drilled and tapped to ½" NPT standard threads. An optional second port can be added to allow through purging between the stem seals or connection of instrumentation and sensing devices.
- Conductive Stem Seal – One chevron-style ring is of electrically conductive TFE to positively ground the stem to the body.
- The valve goes from full open to full closed with 90° operation of the stem. Dual stem seals ensure zero leakage.

- The bonnet and body are cast as a single piece. There are no welds, crevices or static seals to fracture and leak.
- The Series 94 is available with stainless steel or Hastelloy® C anti-corrosion trim to meet NACE MRO 1-75.

Consider these benefits ...

- High vacuum capability (tight shutoff to 1×10^{-3} Torr and higher).
- Extremely high-cycle life (more than 20 times that of a conventional stem seal design).
- For automated versions, the actuator can be removed without affecting the integrity of the valve seals.
- The extended bonnet allows easy stem access after insulation. It also provides thermal isolation of the actuation mechanism.
- Pneumatic and electric modulating packages with either standard or characterized seats are the only solution in applications where traditional rising stem control valves just cannot be used.

Special Testing and Preparation Available

Options

- Assembled in a Class 100 clean assembly area
- Helium leak tested
- UV and wipe tested for hydrocarbons and residue
- Specially cleaned and bagged for oxygen and chlorine service
- Hydro tested
- CMTRs and full compliance to B16.34

Applications

Worcester developed the Series 94 available for either on-off or throttling services with the following applications in mind:

- Leak-off systems with sensing devices and alarms for fugitive emissions
- Category M materials
- Applications requiring extremely high cycle life
- Chlorine applications requiring a high-performance stem seal design
- Superheated water (400°F and 400 psi)
- High-temperature applications and/or high pressure drops requiring metal-seated versions
- High temperatures above 500°F requiring a Grafoil stem packing
- Phosgene gas and other highly toxic media requiring zero leakage

Steam

High-cycle steam valves are subject to wide thermal swings.

Polymer Lines

The Series 94 valve, using FEP or PFA seats and seals, is a technical improvement designed for use in polymer lines.

Cryogenics

A bonnet extension on the Series 94 valve provides the thermal conductivity to maintain ambient temperatures on the stem seals.

Specifications

Series 94 Flanged (94-150, 94-300 & 94-600)

Sizes	½", ¾", 1", 1½", 2", 3", 4", 6" & 8"
Flanges	94-150 (ANSI 150# raised face) 94-300 (ANSI 300# raised face) 94-600 (ANSI 600# raised face – 1"-3")
Body Materials	Stainless steel, carbon steel
Stem	316 S.S or Hastelloy C
Stem Seals	Virgin TFE, Grafoil, Carbon-filled TFE
Seats	Metal "A", Metal "G", High-per Fill®, TFE, Polyfill®, RTFE or UHMWPE
Body Seals	TFE or graphite-coated stainless steel "S" gasket, TFE, Viton® or Grafoil
Ball	316 S.S or Hastelloy C
Options	One leak-off port drilled and tapped to ⅛" NPT standard. Optional second port for purging.
Operation	Lever handle, pneumatic or electric automation (on/off or proportional control)
Standards	ANSI B16.5 (flange dimensions), B16.10 (face-to-face dimensions), B16.34, B31.1, B31.3 (including category M materials and MSS SP-72)

Series 94 3-Piece

Sizes	¼" - 2"
Ends	Screwed Ends, Socket Weld, Butt Weld
Body Materials	Stainless steel, carbon steel
Stem	316 S.S or Hastelloy C
Stem Seals	Virgin TFE, Grafoil, Carbon-filled TFE
Seats	Metal "A", Metal "G", High-per Fill, TFE, Polyfill, RTFE or UHMWPE
Body Seals	Graphite-coated "S" gasket, TFE coated "S" gasket, TFE, Viton
Ball	316 S.S or Hastelloy C
Options	One leak-off port drilled and tapped to ⅛" NPT standard. Optional second port for purging.
Operation	Lever handle, pneumatic or electric automation (on/off or proportional control)
Standards	ANSI B1.20.1 (for SE, NPT threads), B16.11 (for SW socket dimensions only), B16.34, B31.1, B31.3 (including category M materials) and MSS SP-72 API 607 Edition 4, and EXES 3-14-1-2A fire test approvals.

Specifications

NOTES: Body seals have pressure/temperature ratings that equal or exceed the rating of the seat. TFE body seals will not withstand thermal cycles in excess of 200°F.

Ratings for Metal "A" and "G" and High-per Fill Seats

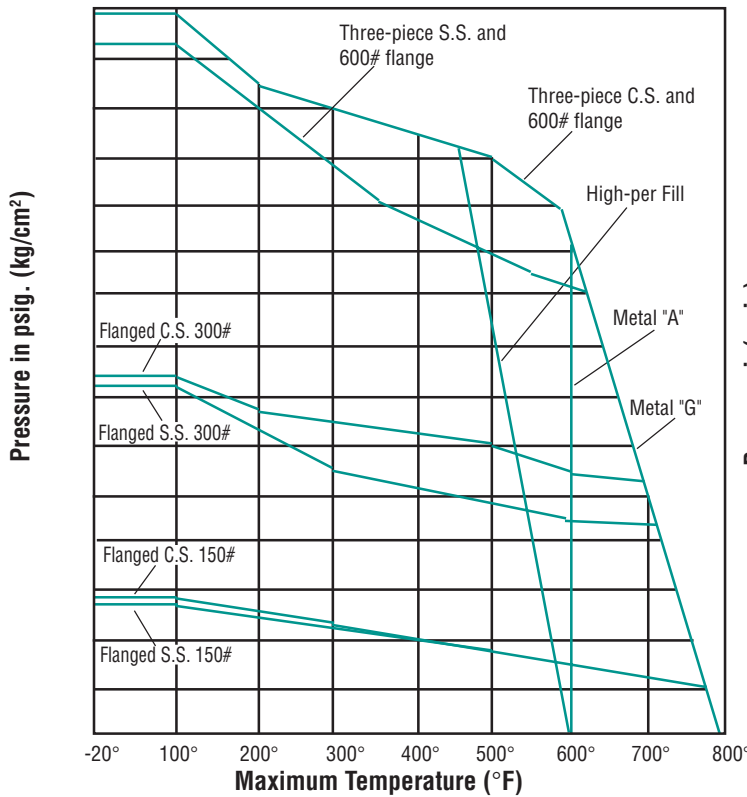

Ratings for Polyfill, RTFE, UHMWPE and TFE Seats

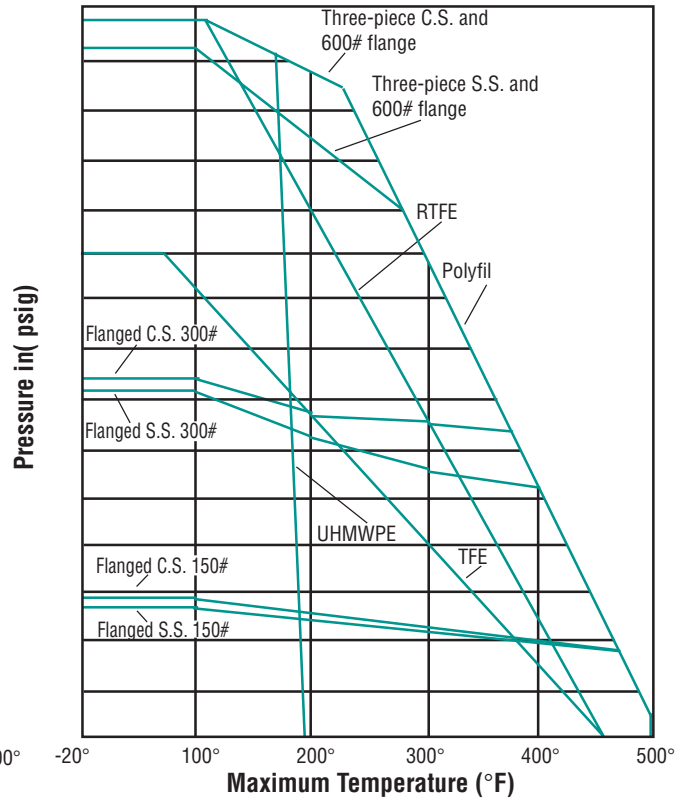

Cv Values and Equivalent Lengths of Pipe

Three-Piece

Valve Size	Cv	Equiv. length of sched. 40 pipe ft.
1/4" - 3/8"	8	0.9
1/2"	8	3.1
3/4"	12	6.3
1"	32	3.1
1 1/4"	46	6.3
1 1/2"	82	4.3
2"	120	7.5

Flanged

Valve Size	Cv	Equiv. length of sched. 40 pipe ft.
1"	32	3.6
1-1/2"	89	3.7
2"	130	6.5
3"	350	6.5
4"	720	6.9
6"	1020	20.4
8"	1800	37.7

Dimensions for 94 Three-Piece

inches (mm)

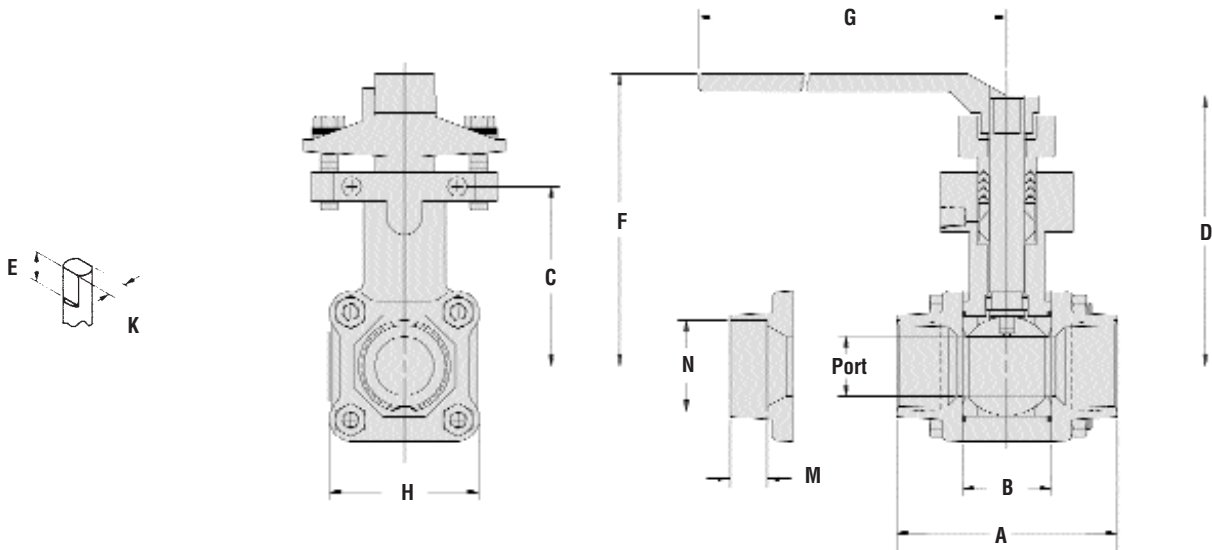

1/4"-2" 94 Three-Piece Dimensions

Valve Size	A	B	C	D	E	F	G	H	K	M	N	Port	Weight lb. (kg)
1/4"	2.54 (64.52)	.813 (20.65)	2.67 (67.82)	4.40 (111.76)	.70 (17.78)	4.75 (120.65)	8.00 (203.20)	1.75 (44.45)	.296 (7.52)	.44 (11.18)	.555 (14.10)	.44 (11.18)	2 (.91)
3/8"	2.54 (64.52)	.813 (20.65)	2.67 (67.82)	4.40 (111.76)	.70 (17.78)	4.75 (120.65)	8.00 (203.20)	1.75 (44.45)	.296 (7.52)	.44 (11.18)	.690 (17.53)	.44 (11.18)	2 (.91)
1/2"	2.54 (64.52)	.813 (20.65)	2.67 (67.82)	4.40 (111.76)	.70 (17.78)	4.75 (120.65)	8.00 (203.20)	1.75 (44.45)	.296 (7.52)	.44 (11.18)	.855 (21.72)	.44 (11.18)	3 (1.4)
3/4"	2.76 (70.10)	.969 (24.61)	2.76 (70.10)	4.49 (114.05)	.70 (17.78)	4.84 (122.94)	8.00 (203.20)	2.00 (50.80)	.296 (7.52)	.56 (14.22)	1.065 (27.05)	.56 (14.22)	4 (1.8)
1"	3.66 (92.96)	1.250 (31.75)	3.18 (80.77)	4.91 (124.71)	.70 (17.78)	5.26 (133.60)	8.00 (203.20)	2.38 (60.45)	.343 (8.71)	.72 (18.29)	1.330 (33.78)	.81 (20.57)	5 (23)
1 1/4"	4.16 (105.66)	1.625 (41.27)	3.37 (85.60)	5.10 (129.54)	.70 (17.78)	5.45 (138.43)	8.00 (203.20)	2.70 (68.58)	.343 (8.71)	.72 (18.29)	1.675 (42.55)	1.00 (25.40)	10 (4.5)
1 1/2"	4.50 (114.36)	1.906 (48.41)	3.82 (97.03)	5.66 (143.76)	.75 (19.05)	6.14 (155.96)	10.00 (254.00)	3.16 (80.26)	.500 (12.70)	.72 (18.29)	1.915 (48.64)	1.25 (31.75)	11 (5.0)
2"	4.94 (125.48)	2.213 (56.21)	4.01 (101.85)	5.85 (148.59)	.75 (19.05)	6.33 (160.78)	10.00 (254.00)	3.56 (90.42)	.500 (12.70)	.84 (21.34)	2.406 (61.11)	1.50 (38.1)	13 (5.9)

Dimensions for 94 150/300 Flanged

1/2"-2" 94 150/300# Flanged

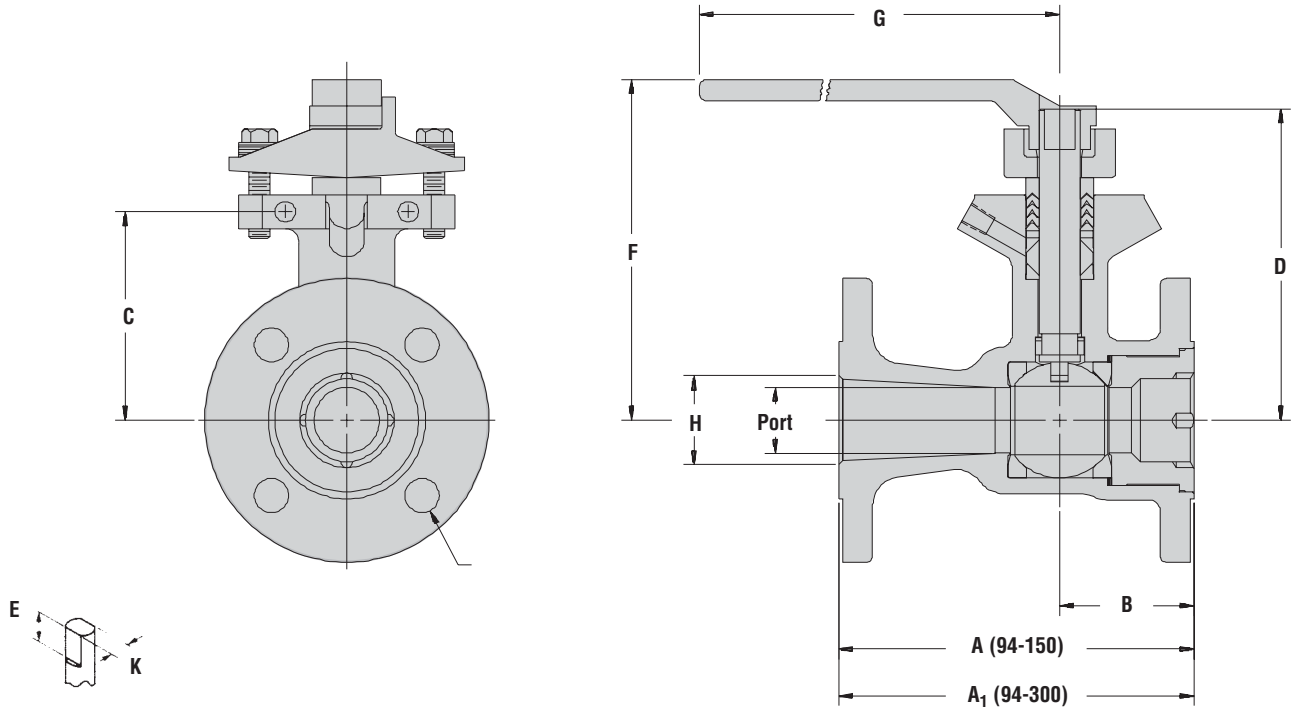

3"-8" 94 150/300# Flanged

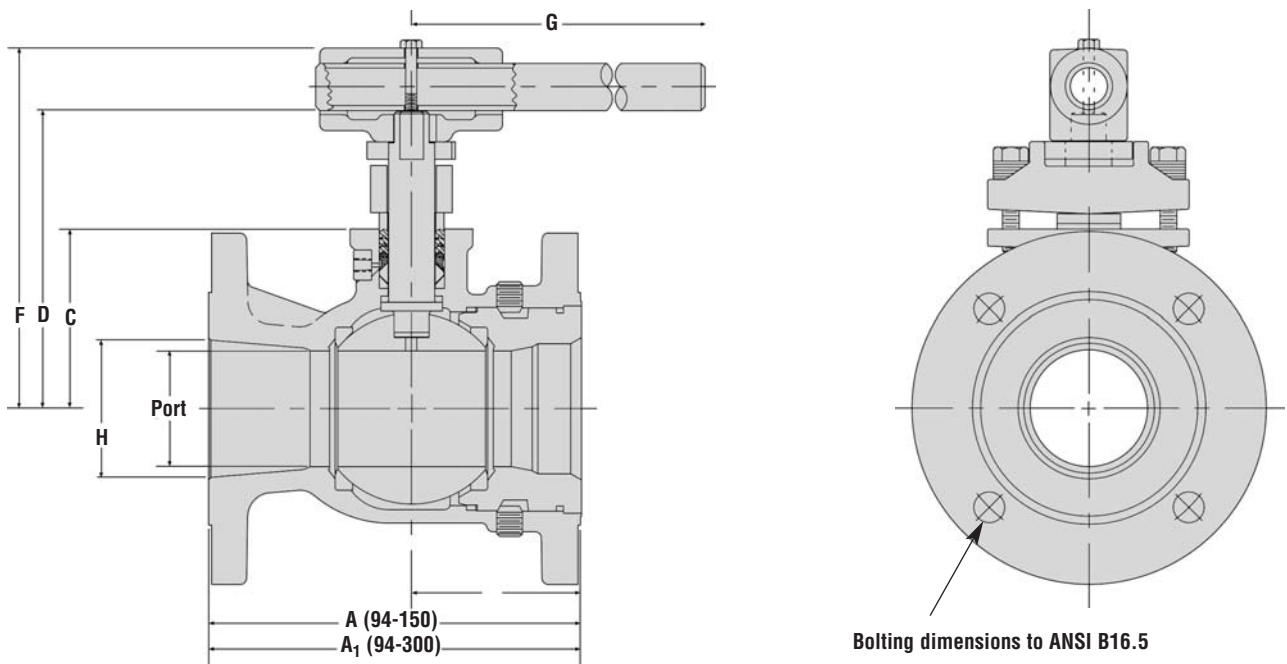

Dimensions for 94 150/300 Flanged

inches (mm)

Valve Size	A	A1	B	C	D	E	F	G	H	K	Port	150#	300#
1/2"	4.25 (107.95)	5.50 (139.70)	1.81 (45.97)	2.67 (67.82)	4.40 (111.76)	.70 (17.78)	4.75 (120.65)	8.00 (203.20)	.59 (14.99)	.296 (7.52)	.44 (11.18)	5.3 (2.4)	6.3 (2.9)
3/4"	4.62 (117.35)	6.00 (152.40)	1.94 (49.28)	2.76 (70.10)	4.49 (114.05)	.70 (17.78)	4.84 (122.94)	8.00 (203.20)	.83 (21.08)	.296 (7.52)	.56 (14.22)	8 (3.6)	8.9 (4.0)
1"	5.00 (127.0)	6.50 (165.1)	2.25 (57.2)	3.18 (80.77)	4.91 (124.71)	.70 (17.78)	5.26 (133.60)	8.00 (203.20)	1.05 (26.67)	.343 (8.71)	.81 (20.57)	11 (4.9)	12.5 (5.7)
1 1/2"	6.50 (165.10)	7.50 (190.50)	2.45 (62.23)	3.82 (97.03)	5.66 (143.76)	.75 (19.05)	6.14 (155.96)	10.00 (254.00)	1.63 (41.40)	.500 (12.70)	1.25 (31.75)	16 (7.3)	19.1 (8.7)
2"	7.00 (177.80)	8.50 (215.90)	2.67 (67.82)	4.01 (101.85)	5.85 (148.45)	.75 (19.05)	6.33 (160.78)	10.00 (254.00)	2.01 (51.05)	.500 (12.70)	1.50 (38.10)	22 (10.0)	26 (11.8)
3"	8.00 (203.20)	11.12 (282.45)	3.62 (91.95)	3.88 (98.55)	6.38 (162.05)	.66 (16.76)	7.91 (200.91)	22.00 (558.80)	3.06 (77.72)	.745 (18.92)	2.50 (63.50)	40 (18.2)	50 (22.7)
4"	9.00 (228.60)	12.00 (304.80)	4.00 (101.60)	4.48 (113.79)	7.00 (177.80)	.66 (16.76)	8.53 (216.66)	22.00 (558.80)	4.03 (102.36)	.745 (18.92)	3.25 (82.55)	62 (28.1)	80 (36.3)
6"	10.50 (266.7)	15.88 (403.35)	4.25 (107.95)	6.19 (157.23)	9.15 (232.41)	1.03 (26.19)	11.40 (289.56)	26.00 (660.4)	6.06 (153.92)	1.120 (28.45)	4.38 (111.25)	125 (56.7)	150 (68.0)
8"	11.50 (292.0)	16.50 (419.1)	5.69 (144.5)	7.28 (184.9)	10.50 (265.3)	1.03 (26.19)	12.31 (312.7)	26.00 (660.4)	8.00 (203.2)	1.120 (28.45)	5.69 (144.5)	184 (83.5)	225 (102.1)

Dimensions are for layout purposes only. For tolerances, contact Flowserve. Metric dimensions are converted from standard English.

Dimensions for 94 600 Flanged

inches (mm)

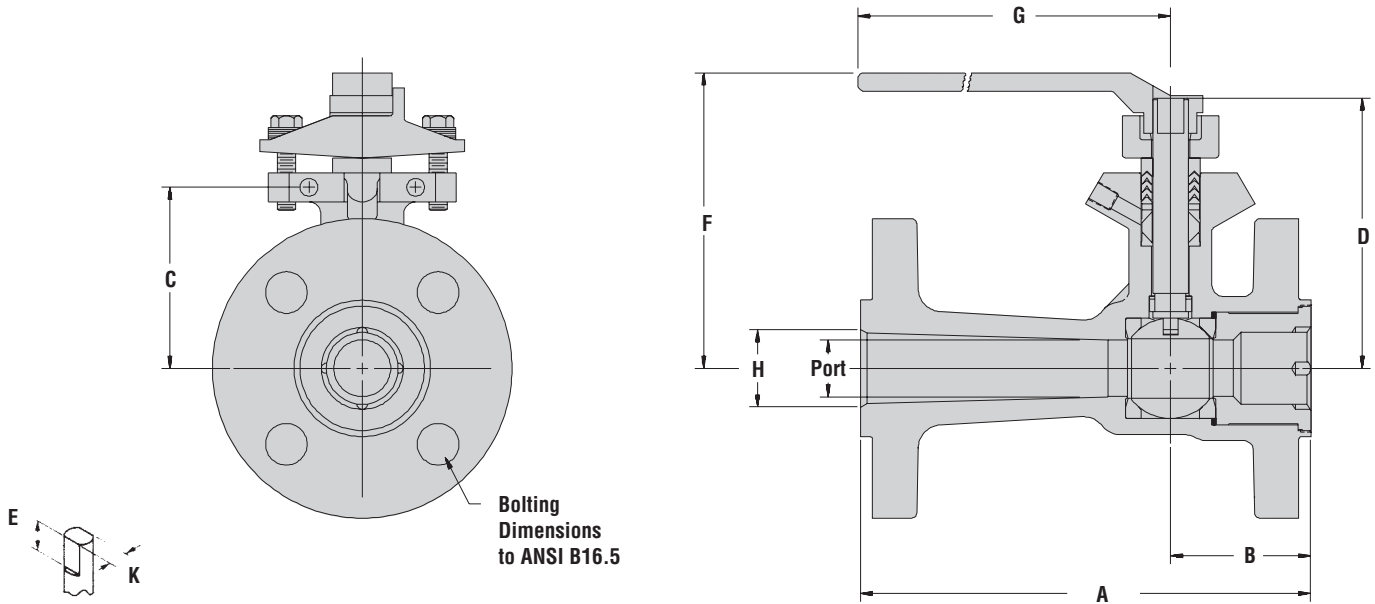

1"-2" 94 600# Flanged

Valve Size	A	B	C	D	E	F	G	H	K	Port	Weight lb. (kg)
1"	8.50 (215.9)	2.75 (69.85)	3.18 (80.77)	4.91 (124.71)	.70 (17.78)	5.26 (133.60)	8.00 (203.20)	1.05 (26.67)	.343 (8.71)	.81 (20.57)	19.5 (8.85)
1½"	9.50 (241.3)	2.96 (75.18)	3.82 (97.03)	5.66 (143.76)	.75 (19.05)	6.14 (155.96)	10.0 (254.00)	1.63 (41.40)	.500 (12.70)	1.25 (31.75)	37 (16.80)
2"	11.50 (292.1)	3.17 (80.52)	4.01 (101.85)	5.85 (148.45)	.75 (19.05)	6.33 (160.78)	10.00 (254.00)	2.01 (51.05)	.500 (12.70)	1.50 (38.10)	48 (21.79)

Series 94-150, 94-300 and 94-600 (Flanged)

Part No.	Part Name	Qty. per Valve	Materials
1	Body	1	Stainless Steel ASTM A351-CF8M Carbon Steel ASTM A216-WCB, Black Oxide Coated
2	End Plug	1	Stainless Steel ASTM A479-316 or A351-CF8M Carbon Steel 1008-1030, Black Oxide Coated
3	Ball	1	Stainless Steel ASTM A479-316 (1/2"-2"), A351-CF8M (3"-8") Hastelloy C ASTM B574-N10276
4	Stem	1	Stainless Steel ASTM A479-316 Hastelloy C ASTM B574-N10276
5	Seat	2	TFE, Reinforced TFE, Polyfill, UHMWPE, High-per Fill, Metal "A" & Metal "G"
6	Body Seal	1	TFE, Viton, Stainless Steel AISI-316, TFE or Graphite Coated (1/2"-2") Grafoil (3"-8")
NOT SHOWN	Seat Seal (Metal Seats Only)	2	See illustration on page 10 (3-Piece) for reference
7	Thrust Bearing	1	Celazole PBI (1/2"-3/4" & 1"-2" with G, U or X Seats), Polyfill (1"-2" only), Carbon filled TFE or Grafoil (3"-8" only)
8	Filler Ring	1	TFE or Grafoil (1 solid ring)
9	629 Seal	1	TFE or Grafoil (1 solid ring)
10	Lantern Ring	1	Stainless Steel ASTM A479-316 Hastelloy C ASTM B574-N10276
11	Chevron-Style Ring	2 or 3	1/2"-2"—2 TFE + 1 Carbon-filled TFE or Grafoil 3"-8"—3 TFE or 2 Grafoil
12	Follower T or G	1	Stainless Steel ASTM A479-316L or 316
14	Gland Plate	1	Stainless Steel ASTM A743-CF8M Carbon Steel
15	Gland Bolt	2	Stainless Steel ASTM A193-GR.B8 Alloy 20 for Chlorine Line (ASTM B473S20)
16	Belleville Washer	12	Stainless Steel ASTM A666, Full Hard Carbon Steel AISI C1075
17	Handle (1/2"-2" Only)	1	Ductile Iron ASTM A536, Zinc Plated, Epoxy Coated
18	Handle Set Screw (1/2"-2" Only)	2	Alloy Steel
19	Split Ring (1/2"-2" Only)	1	Hastelloy C ASTM B574-N10276 Stainless Steel ASTM A479-316L
20	Stop (3"-8" Only)	1	Carbon Steel ASTM A366, Zinc Plated
22	Wrench Block (3"-8" Only)	1	Malleable Iron ASTM A47, Black Oxide Coated
23	Hex Head Bolt	1	Carbon Steel SAE J429 GR.2
24	Wrench Extension (3"-8" Only)	1	Carbon Steel ASTM A53
25	End Plug Screw (3"-8")	4-8	Stainless Steel AISI 303, Zinc Plated
26	Name Plate	1	Stainless Steel Grade 304
27	1/8" Plug	1	Stainless Steel 300 Series

1/2"-2"

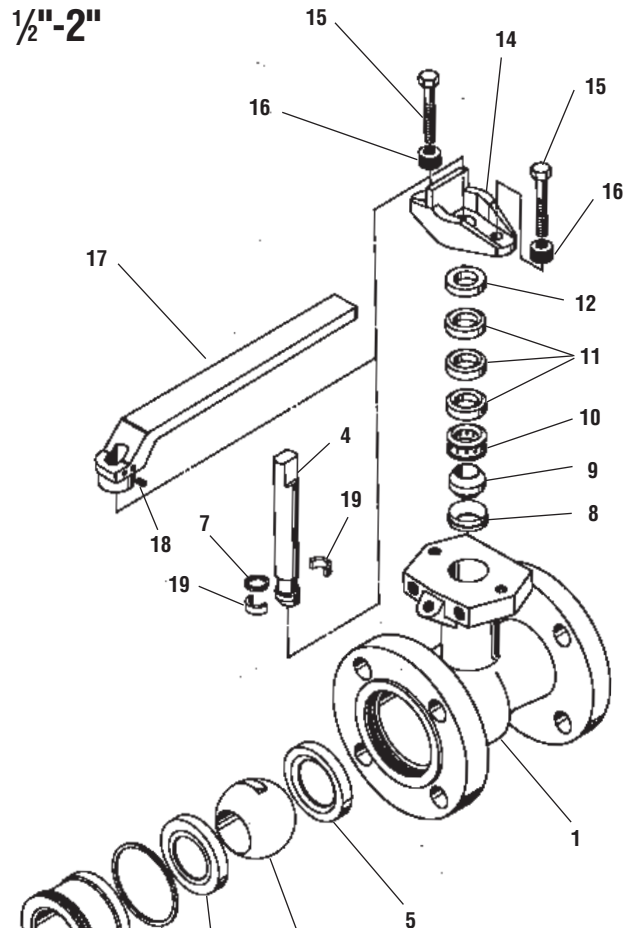

3"-8"

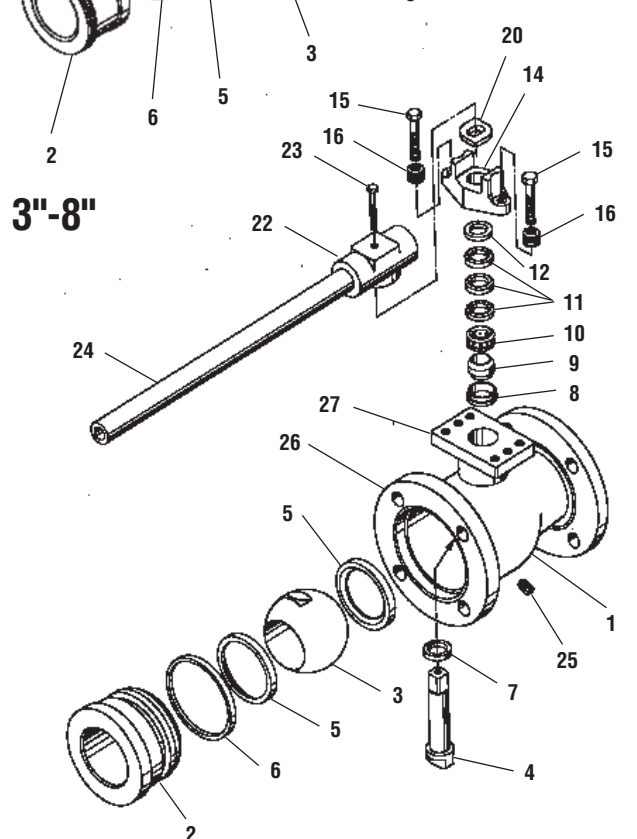

NOTE: Handle ordered separately from valve. See page 11.

Series 94 Three-Piece

Part No.	Part Name	Qty. per Valve	Materials
1	Body	1	Stainless Steel ASTM A351-CF3M, Carbon Steel ASTM A216-WCB, Black Oxide Coated
2	Pipe End	2	Stainless Steel ASTM A351-CF3M, Carbon Steel, ASTM A105 or A216-WCB, Black Oxide Coated
3	Ball	1	Stainless Steel, Hastelloy C ASTM B574-N10276
4	Stem	1	Stainless Steel ASTM A479-316 or Hastelloy C, ASTM B574-N10276
5	Seat	2	TFR, Reinforced TFE, Polyfill, High-per Fill, UHMWPE, Metal "A" & Metal "G"
6	Body Seal	2	Viton, TFE, Stainless Steel AISI 316 (TFE or Graphite Coated)
7	Seat Seal	2	Graphite (Metal "A" and "G" Only)
8	Split Ring	1	Hastelloy C ASTM B574-N10276 or Stainless Steel ASTM A479-316L
9	Thrust bearing	1	Celazole® PBI (1/4"-3/4" & 1"-2" with G, X or U seats), Polyfill (1"-2")
10	Filler Ring	1	TFE or Grafoil (1 Solid Ring)
11	629 Seal	1	TFE or Grafoil (1 Solid Ring)
12	Lantern Ring	1	Stainless Steel ASTM A479-316L Hastelloy C ASTM B574-N10276
13	Chevron-Style Ring	2 or 3	2 TFE + 1 Carbon Filled TFE or 2 Grafoil
14	Follower T or G	1	Stainless Steel ASTM A479-316L or 316
16	Handle	1	Ductile Iron ASTM A536, Zinc Plated, Epoxy Coated
17	Set Screw	2	Alloy Steel
18	Gland Plate	1	Stainless Steel ASTM A743-CF8M Carbon Steel
19	Gland Bolt	2	Stainless Steel ASTM A193-GR B8 Alloy 20 ASTM B473 S20 for CL94
20	Belleville Washer	12	Stainless Steel ASTM A666 Full Hard Carbon Steel AISI C1075
21	Body Bolt	4	Stainless Steel ASTM A193-GR B8 Carbon Steel ASTM A193 GR B7 and 2H
22	Body Nut	4	Stainless Steel ASTM A194-GR 8 Carbon Steel ASTM A193 GR B7 and 2H
23	Name Plate	1	Stainless Steel Grade 304
24	1/8" Plug	1	Stainless Steel 300 Series

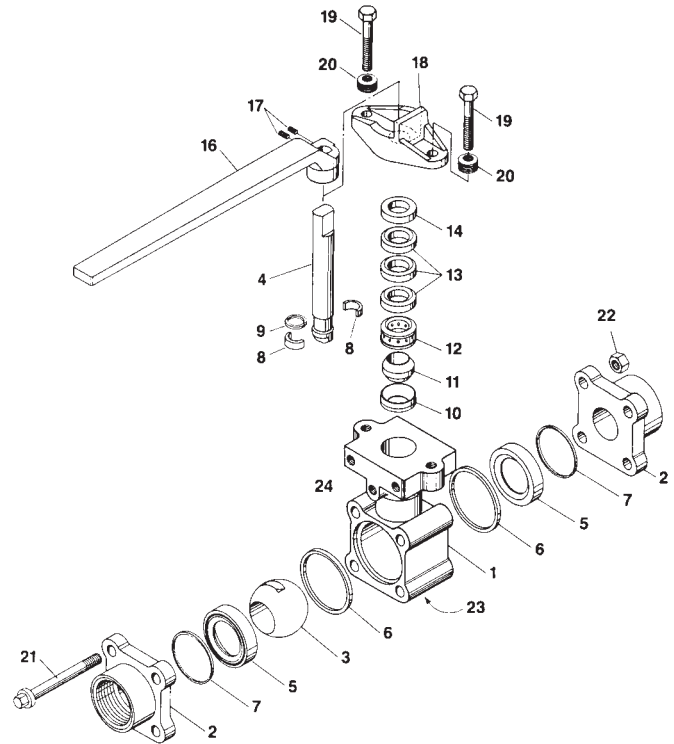

NOTE: Handle ordered separately from valve. See page 11.

How to Order

VALVES: Sample Ordering Code: 2" 9466GGSW would be a 2" Series 94 valve with stainless steel body, pipe ends, ball and stem. It would have graphite impregnated stainless steel seats and graphite coated stainless steel "S" gasket body seals. Pipe ends would be socket weld.

HANDLES: Operating handles are ordered separately. If ordering a 2" 94 valve, order a 2" HK94 handle. Please specify on the order whether you wish the handle mounted at the factory or shipped separately. Example: 2" HK94 handle - factory mounted.

Series 94 150/300/600 Flanged (600# 1"-2" Only)

Valve Size	Series	Body	Ball, Stem	Seats	Body Seal	End Connection
1/2" 3/4" 1" 1 1/2" 2" 3" 4" 6" 8"	94	4 - Carbon Steel 6 - CF8M Stainless Steel	6 - 316 S.S. C - Hastelloy C	A - Metal "A" w/S.S. ball and stem G* - Metal "G" w/S.S. ball and stem X - High-per Fill T** - TFE P** - Polyfill R** - Reinforced TFE U - UHMWPE	M - TFE coated S.S. "S" gasket (1"-2" only) G - Graphite coated S.S. "S" gasket (1"-2" only) Z** - Grafoil (3"-8" only) T** - TFE V - Viton	150 - ANSI 150# Flanges 300 - ANSI 300# Flanges 600 - ANSI 600# Flanges
1/2" 3/4" 1" 1 1/2" 2" 3" 4"	CL94	4 - Carbon Steel	C - Hastelloy C	R - Reinforced TFE	T - TFE	150 - ANSI 150# Flanges 300 - ANSI 300# Flanges

* Available in sizes 1/2"-6" only.

** 8" available only in these options.

Series 94 Three-Piece

Valve Size	Series	Body, Pipe Ends	Ball, Stem	Seats	Body Seals	End Connection
1/4" - 2"	94 - 3-piece	4 - WCB or A105 Carbon Steel 6 - CF3M Stainless Steel	6 - 316 S.S. C - Hastelloy C	A† - Metal "A" w/S.S. ball and stem G - Metal "G" w/S.S. ball and stem X - High-per Fill T - TFE P - Polyfill R - Reinforced TFE U - UHMWPE	M† - TFE coated S.S. "S" gasket G - Graphite coated S.S. "S" gasket T - TFE V - Viton	SE - Screwed End SW - Socket Weld BW4 - Butt Weld, schedule 40 BW8 - Butt weld (C.S.), schedule 80 BW1 - Butt Weld (S.S. only), schedule 10
1/2" - 2"	CL94	4 - Carbon Steel WCB or A105	C - Hastelloy C	T - TFE (1 piece seat/seal)		SE - Screwed End SW - Socket Weld

† AM seat/seal combination with SE only.

Prefixes: V for vacuum service, TFE, reinforced TFE and Polyfill seats only. X for oxygen service, TFE, reinforced TFE and polyfill seats only.



Worcester ... All The Right Valves In All The Right Places

Worcester® is a registered trademark of Flowserve Corporation. Polyfill® is a registered trademark of Flowserve Corporation. Pulsair® is a registered trademark of Flowserve Corporation. High-Per Fill® is a registered trademark of Flowserve Corporation. Grafoil® is a registered trademark of Union Carbide Corp. Viton® is a registered trademark of The DuPont Co. Hastelloy® is a registered trademark of Haynes International. Celazole® is a registered trademark of Hoescht Celanese.

Flowserve Corporation has established industry leadership in the design and manufacture of its products. When properly selected, this Flowserve product is designed to perform its intended function safely during its useful life. However, the purchaser or user of Flowserve products should be aware that Flowserve products might be used in numerous applications under a wide variety of industrial service conditions. Although Flowserve can (and often does) provide general guidelines, it cannot provide specific data and warnings for all possible applications. The purchaser/user must therefore assume the ultimate responsibility for the proper sizing and selection, installation, operation, and maintenance of Flowserve products. The purchaser/user should read and understand the Installation Operation Maintenance (IOM) instructions included with the product, and train its employees and contractors in the safe use of Flowserve products in connection with the specific application.

While the information and specifications contained in this literature are believed to be accurate, they are supplied for informative purposes only and should not be considered certified or as a guarantee of satisfactory results by reliance thereon. Nothing contained herein is to be construed as a warranty or guarantee, express or implied, regarding any matter with respect to this product. Because Flowserve is continually improving and upgrading its product design, the specifications, dimensions and information contained herein are subject to change without notice. Should any question arise concerning these provisions, the purchaser/user should contact Flowserve Corporation at any one of its worldwide operations or offices.

For more information about Flowserve Corporation, contact www.flowserve.com or call USA 1-800-225-6989.

FLOWSERVE CORPORATION
FLOW CONTROL DIVISION
1978 Foreman Drive
Cookeville, Tennessee 38501 USA
Phone: 931 432 4021
Facsimile: 931 432 3105
www.flowserve.com